

BUILDING AUTOMATION
CONTROL TECHNOLOGY
SENSOR TECHNOLOGY

alre



**alre –
simply
control.**

**PRODUCT
CATALOGUE
2026**

OUR SATISFIED CUSTOMERS

HIGH-QUALITY SOLUTIONS FOR EVERY AREA

ALRE-IT Regeltechnik GmbH takes pride in offering a diverse range of solutions tailored to various applications. Our products are ideal for a multitude of settings, including residential properties, hotels, office buildings, and public facilities. With alre controllers, you can expect optimal climate control for any space. For more than five decades, we have been dedicated to fulfilling our customers' needs, crafting professional and high-quality control technology right here in Berlin. Our expertise and commitment to maintaining high quality standards shine through in the numerous successful projects we have completed over the years.



GEORGENHOF, DÖRNBERG QUARTER, REGENSBURG, GERMANY



WOHNANLAGE FONTANEHÖFE, BERLIN, GERMANY



HAUS DES RUNDFUNKS, BERLIN, GERMANY



DATEV LOCATION I, PAUMGARTNERSTRASSE, NUREMBERG, GERMANY



HOTEL PARK INN BY RADISSON, ALEXANDERPLATZ, BERLIN, GERMANY

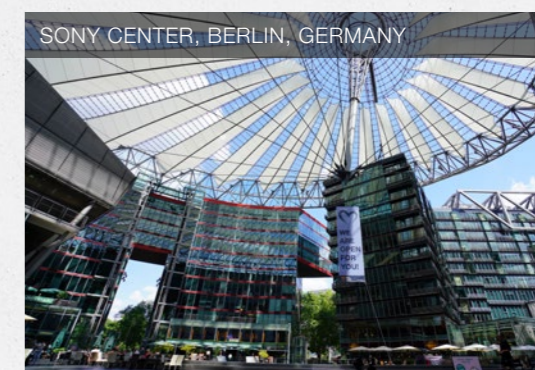

SONY CENTER, BERLIN, GERMANY



WOHNANLAGE WITZLEBENSTRASSE, BERLIN, GERMANY

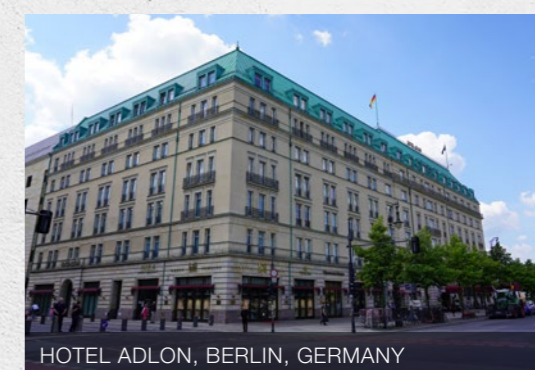

HOTEL ADLON, BERLIN, GERMANY



FRIENDS TOWERS, MUNICH, GERMANY



DATEV STANDORT III SIGMUNDSTRASSE, NUREMBERG, GERMANY

NEW IN 2026

HEATING TECHNOLOGY 'STELLA' ACTUATOR

'Stella' – the intelligent autonomous 230 VAC NC electrothermal actuator for automatic adaptive hydraulic balancing of heating manifolds' heating circuits in surface heating and surface cooling systems.



ADDITIONAL INFORMATION
BEGINNING ON PAGE 108

HEATING TECHNOLOGY ROOM TEMPERATURE CONTROLLER MECHANICAL RTBSU

Electromechanical flush-mounted room temperature controller for controlling or monitoring temperatures in offices, homes and hotels.



ADDITIONAL INFORMATION
BEGINNING ON PAGE 73

HEATING TECHNOLOGY ELECTRONIC ROOM TEMPERATURE CONTROLLER HTRRUT FLUSH-MOUNTED

Electronic surface-mounted room temperature controller for controlling or monitoring temperatures in offices, homes and hotels.



ADDITIONAL INFORMATION
BEGINNING ON PAGE 90

HEATING TECHNOLOGY ELECTRONIC ROOM TEMPERATURE CONTROLLER HTRRBD 'SURFACE-MOUNTED ULTRA-SLIM'

Electronic surface-mounted room temperature controller for controlling or monitoring temperatures in offices, homes and hotels.



ADDITIONAL INFORMATION
BEGINNING ON PAGE 70



WIRELESS SYSTEMS 9

System information	12
Individual components	16



BUILDING AUTOMATION 31

System information	35
Individual components	45



HEATING TECHNOLOGY 51

Room/floor temperature controllers	59
Terminal strips for heating manifolds/valve actuators	110



AIR CONDITIONING TECHNOLOGY 113

Climate controller	119
Dew point monitoring	139
Hygrostats, /Hygro-thermostats	142
Terminal strips for heating/cooling manifolds/valve actuators	145



PLANT ENGINEERING 151

Capillary and wet room thermostats, frost protection thermostats	162
Control cabinet controllers	188
Temperature controllers, electronic	192
Humidity, (air)flow and pressure monitoring	195



SENSOR TECHNOLOGY 207

Temperature	210
Differential pressure	222



ACCESSORIES 223

Sauna controllers	226
Accessories	228
Technical annex	234
Index	246
General information/contact/addresses	250



WIRELESS SYSTEMS

FLEXIBLE AND EFFICIENT



ALRE WIRELESS TECHNOLOGY, COMMAND THE CLIMATE EFFORTLESSLY AND WIRELESSLY.



OVERVIEW

10

SYSTEM INFORMATION

Wireless systems components overview	12
System configuration	14

INDIVIDUAL COMPONENTS

Sensors	16
Heating actuators	22
Actuators (cooling)	26
Actuators (heating / cooling)	28

Whether it's a home, an office or a hotel room, you can use our wireless systems to control your heating and cooling remotely via your home network. Thanks to intuitive, convenient programming and monitoring, you can enjoy the highest level of comfort and optimal energy consumption. Our wide range of sensors, controllers and wireless strips, as well as flush-mounted and surface-mounted solutions, guarantee flexible combination options and the perfect individual solution – for wireless retrofitting endeavours, too. Our highly communicative controllers fit perfectly into any environment, guarantee efficient indoor climate control and are easy on both your wallet and the environment.

alre wireless – intelligent solutions for intelligent buildings.

APPLICATION EXAMPLES:

- + Hot water underfloor heating
- + Hot water radiators
- + Infrared heaters
(e.g., natural stone heaters)
- + Cooling ceilings
- + Electric floor heating



WIRELESS ROOM TEMPERATURE SENSOR WITH CLOCK, FLUSH-MOUNTED, ALRE FRAME



WIRELESS ROOM TEMPERATURE SENSOR, SURFACE-MOUNTED, ULTRA-SLIM



WIRELESS ROOM TEMPERATURE SENSOR WITH CLOCK, SURFACE-MOUNTED



WIRELESS HEATING ACTUATOR FOR INSTALLATION IN HEATING MANIFOLDS

WIRELESS SYSTEMS COMPONENTS OVERVIEW

	FTRFB-	FTRFBu-	FTRFuD	HTFMA-	HTFRB-	HTFRU-	HTFRL-	CTFRB-	KTFRL-					
TYPE														
PAGE	280,101	280,119	280,120	180,117/V2	180,121/V2	210,123#xx	180,161	010,101	110,124	214,240	316,225	010,101	213,140	315,125
PAGE	16	16	17	17	17	17	22	22	23	23	23	26	28	28
CONTROL FUNCTION														
heating	x	x	x	x	x	x	x	x	x	x	x		x	x
Cooling	x	x	x	x	x	x						x	x	x
APPLICATION														
Radiator	x	x	x	x	x	x	x							
Hot water floor heating	x	x	x	x	x	x		x	x	x	x		x	x
Electric underfloor heating	x	x	x	x	x	x		x	x					
Infrared heaters	x	x	x	x	x	x		x						
Cooling ceiling	x	x	x	x	x	x						x	x	x
SENSOR														
NTC, internal	x	x	x	x	x	x								
External NTC (optional)						x								
External NTC for floor control and/or floor monitoring (optional)									x					
Dew point sensor (optional)													x	x
FEATURES														
'ECO' input													x	x
'Changeover – heating/cooling' input													x	x
'Off with frost protection monitoring' input													x	x
Central control	x	x	x	x	x	x		x	x			x	x	x
External antenna can be connected										x	x		x	x
MOUNTING/ATTACHMENT														
Surface / wall-mounted	x	x	x	x	x			x		x	x	x	x	x
Flush-mounted						x			x					
M30x1.5 (adapter for Danfoss RA, RAV, RAVL included)							x							
CONNECTIVITY OF INDIVIDUAL COMPONENTS														
FTRFB-280.101								x	x	x	x	x	x	x
FTRFB-280.119							x	x	x	x	x	x	x	x
FTRFB-280.120							x	x	x	x	x	x	x	x
FTRFBu-180.117/V2							x	x	x	x	x	x	x	x
FTRFBu-180.121/V2							x	x	x	x	x	x	x	x
FTRFuD 210.123#xx							x	x	x	x	x	x	x	x



SYSTEM CONFIGURATION FOR A WIRELESS CONTROL SYSTEM

1 SELECTION OF SENSORS

A minimal system consists of at least one sensor and one actuator. These are directly connected to each other without a central component. Different control functions can be implemented by combining the different sensor types. It is possible to teach any number of actuators to work with the sensors.

INDIVIDUAL ROOM CONTROL

In each room, there is a sensor to detect and set the room temperature. Depending on the selected sensor, further functions may be available.



INDIVIDUAL ROOM CONTROL WITH INDIVIDUAL CLOCK PROGRAM

In each room, there is a sensor with a clock to detect and set the room temperature. An individual clock programme can therefore be set up for each room.

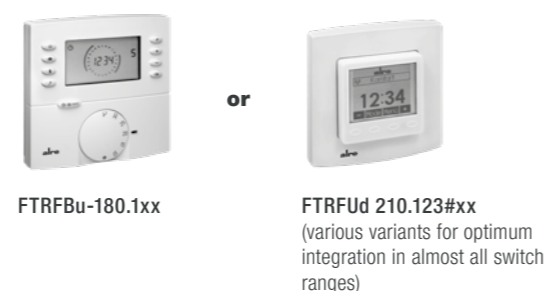

INDIVIDUAL ROOM CONTROL WITH CENTRAL CLOCK PROGRAM (MASTER-SLAVE)

In one room, there is a sensor with a clock to detect and set the room temperature, as well as to set up the central clock program. In the other rooms (any number), there is a sensor to detect and set the room temperature. The clock program set centrally affects all rooms (any number, depending on the wireless range).

Sensor with clock to detect and set the room temperature and set up the central clock programme

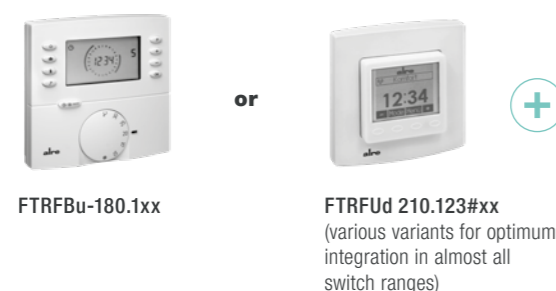

Sensor to detect and set room temperature



CENTRAL CONTROL INDIVIDUAL ROOM CONTROL WITH CENTRAL TEMPERATURE SETTING

One FTRFB-280.101 sensor is required per room (any number) to detect the room temperature. Furthermore, a sensor is required to set the room temperature centrally. The room temperature set centrally applies to all rooms.

Sensor for centrally setting room temperature

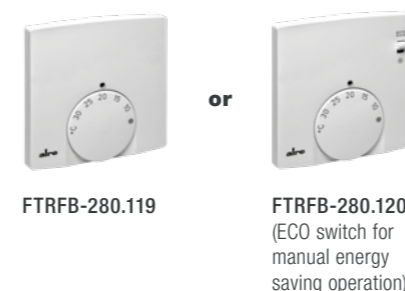

Sensor to detect room temperature

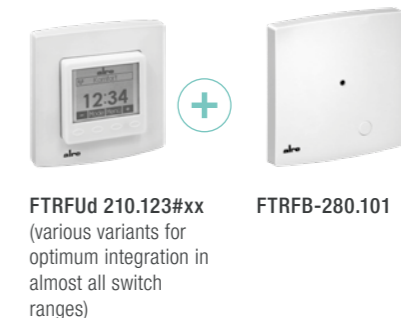

FINDING AVERAGES

Up to 7 additional FTRFB-280.101 sensors can be used per room for finding averages (for example in large rooms). This is possible with all listed control functions.

2 SELECTION OF ACTUATORS

Depending on the type of heating used, a corresponding actuator is required for each room or heating/cooling zone. Any number of actuators/ducts can be assigned to a room.

Hot water underfloor heating



For example:
HTFRL-214.240 (4-channel)
HTFRL-316.225 (8-channel)

Hot water radiators



For example:
HTFMA-180.161

Electrical underfloor heating



For example:
HTFRU-110.124 (optional external floor sensor available)

Infrared heaters



For example:
HTFRB 010.101 or for cooling CTRFB 010.101

Cooling ceiling



For example:
KTRFL-214.140 (4-channel)
KTRFL-316.125 (8-channel)

OPTIONAL

If required, an external antenna (JZ-25) can be connected to the multi-channel actuators intended for installation in heating manifolds via a 1m antenna cable (JZ-26).

WIRELESS SYSTEMS – SENSORS



TECHNICAL DATA

Permissible atmospheric humidity: max. 95% rel. humidity, non-condensing
Protection rating: IP30
Safety and EMC: according to DIN EN 60730 and DIN EN 300220
Radio frequency: 868.3 MHz
Range: 150 m line-of-sight or up to 30 m in buildings, depending on the construction
Transmission interval: approx. 3 min and after setpoint change



APPLICATION

Wireless room temperature sensors for measuring temperature in home, office and hotel rooms with normal levels of cleanliness. Single-room temperature control can be implemented with alre wireless actuators. Primarily targets use in renovation applications or for heating system extensions.





Battery change: The sensor indicates if a battery change is required soon.

The wireless connection is restored automatically after a voltage interruption at the sensor or actuator.











TYPE/IMAGE	ITEM NO.	FEATURES	EURO/PG
 only 13.9 mm deep		General features: wireless room temperature sensor to detect and set room temperature; 'learning mode/battery discharge state' display; mechanical range restriction; scale: degrees Celsius; external setting Design: Berlin 1000 Surface finish: glossy Housing colour: pure white, similar to RAL 9010 Housing material: ABS plastic Operating voltage: 2x micro AAA batteries, 1.5 V Ambient temperature: -10 to +50 °C Storage temperature: -10 to +50 °C Mounting/attachment: direct surface/wall mounting by means of screws or adhesive pads Protection class: III Sensor: NTC, internal Setting range: 5 to 30 °C Scope of delivery: device, batteries, adhesive pads Operating elements: Learn button	124.40/I
 only 13.9 mm deep	BA010400	General features: Wireless room temperature sensor to detect the room temperature for calculating the average value or for centralised control; 'learning mode/battery discharge state' display Design: Berlin 1000 Surface finish: glossy Housing colour: pure white, similar to RAL 9010 Housing material: ABS plastic Operating voltage: 2x micro AAA batteries, 1.5 V Ambient temperature: -10 to +50 °C Storage temperature: -10 to +50 °C Mounting/attachment: direct surface/wall mounting by means of screws or adhesive pads Protection class: III Sensor: internal NTC Scope of delivery: device, batteries, adhesive pads Operating elements: Learn button	120.10/I



WIRELESS SYSTEMS – SENSORS

TYPE/IMAGE	ITEM NO.	FEATURES	EURO/PG
 only 13.9 mm deep	BA010401	General features: wireless room temperature sensor to detect and set room temperature; reduction 4 K fixed; ECO function; 'learning mode/battery discharge state' display; mechanical range restriction; scale: degrees Celsius; external setting Design: Berlin 1000 Surface finish: glossy Housing colour: pure white, similar to RAL 9010 Housing material: ABS plastic Operating voltage: 2x micro AAA batteries, 1.5 V, 1,100 mAh Ambient temperature: -10 to +50 °C Storage temperature: -10 to +50 °C Mounting/attachment: direct surface/wall mounting by means of screws or adhesive pads Protection class: III Sensor: NTC, internal Setting range: 5 to 30 °C Scope of delivery: device, batteries, adhesive pads Operating elements: 'Comfort/ECO' switch, learn button	135.60/I
	BA010200	General features: wireless room temperature sensor to detect and set the room temperature with clock pilot function; ECO function, ECO value adjustable; 'ECO' display; 'on/off' display; 'learning mode/battery discharged state' display; digital actual value display; child-safe features; actual value correction/measured value correction; learning function; valve protection; holiday setting; party setting; automatic adjustment to summer/winter time; mechanical range setting; scale: degrees Celsius; reduction/comfort/automatic button; external setting; operation using direct-dial buttons; on/off button; information button; party function button; holiday setting button; master-slave operation; 'heating', 'cooling' or 'heating and cooling' mode Design: Berlin 3000 Surface finish: matt Housing colour: pure white, similar to RAL 9010 Housing material: ABS plastic Operating voltage: 2x micro AAA batteries, 1.5 V, 1,100 mAh Ambient temperature: -10 to 50 °C Storage temperature: -10 to +50 °C Mounting/attachment: direct surface/wall mounting by means of screws or adhesive pads Protection class: III Sensor: NTC, internal Setting range: 5 to 30 °C Display type: symbol display Scope of delivery: device, batteries, adhesive pads Accessories: optional adapter snap-on plate JZ-18	220.30/I
	BA010201	Similar to FTRFBu-180.117, but with backlighting Operating voltage: 3x micro AAA batteries, 1.5 V (3rd battery for backlighting)	253.50/I
	UA080000	General features: Flush-mounted wireless room temperature sensor to detect and set the room temperature with clock, holiday setting, party setting, different clock programs can be set for heating and cooling, usable as the master for master-slave operation (pilot controller); pilot function; ECO function; ECO value adjustable; 'ECO' display; 'on/off' display; digital actual value display; backlighting; child-safe features; power reserve (3 days); actual value correction/measured value correction; learning function; valve protection; holiday setting; party setting; automatic adjustment to summer/winter time; external setting; operation using direct-dial buttons Design: Berlin flush-mounted Surface finish: glossy Housing colour: pure white, similar to RAL 9010 Housing material: ABS, PC, PMMA plastic Operating voltage: 230 VAC, 50 Hz Ambient temperature: 0 to 40 °C Storage temperature: -20 to +70 °C Electrical connection: pluggable screw terminals Mounting: in flush-mounted socket (deep flush-mounted socket recommended); can be adapted to fit virtually any surface switch range, see page 21 Protection class: II, if properly mounted Average power consumption: <1 W Sensor: NTC internal, optional external (selection option from 7 different sensors, e.g., 'Sensor 2'/'Sensor 8') Control range: 5 to 30 °C Display type: illuminated graphic display Scope of delivery: controller, 50 x 50 mm cover pure white (similar to RAL 9010), glossy, alre frame 'Berlin'	309.60/I

WIRELESS SYSTEMS – SENSORS

TYPE/IMAGE	ITEM NO.	FEATURES	EURO/PG
	UA080001	Similar to FTRFud 210.123#21 but scope of delivery as follows: wireless room temperature sensor, 50 x 50 mm cover pure white (similar to RAL 9010), glossy , without frame	305.30/I
	UA080002	Similar to FTRFud 210.123#21 but scope of delivery as follows: wireless room temperature sensor, 50 x 50 mm cover pearl white (similar to RAL 1013), glossy , without frame	305.30/I
	UA080003	Similar to FTRFud 210.123#21 but scope of delivery as follows: wireless room temperature sensor, 50 x 50 mm cover traffic white (similar to RAL 9016), glossy , without frame	305.30/I
	UA080006	Similar to FTRFud 210.123#21 but scope of delivery as follows: wireless room temperature sensor, cover suitable for BUSCH-JAEGER Reflex SI/SI Linear pure white (similar to RAL 9010), glossy , without frame	307.30/I
	UA080004	Similar to FTRFud 210.123#21 but scope of delivery as follows: Wireless room temperature sensor, 55 x 55 mm cover pure white (similar to RAL 9010), glossy , without frame	307.30/I
	UA080008	Similar to FTRFud 210.123#21 but scope of delivery as follows: wireless room temperature sensor, 55 x 55 mm cover pure white (similar to RAL 9010), mat , without frame	307.30/I
	UA080005	Similar to FTRFud 210.123#21 but scope of delivery as follows: wireless room temperature sensor, 55 x 55 mm cover pearl white (similar to RAL 1013), glossy , without frame	307.30/I
	UA080007	Similar to FTRFud 210.123#21 but scope of delivery as follows: wireless room temperature sensor, 55 x 55 mm cover traffic white (similar to RAL 9016), glossy , without frame	307.30/I

WIRELESS SYSTEMS – SENSORS

TYPE/IMAGE	ITEM NO.	FEATURES	EURO/PG
	MN990002	General features: Optional adapter snap-action plate for wireless room temperature sensor FTRFbu with universal perforation pattern for mounting. The use of the adapter is recommended since the device becomes detachable as a result, which facilitates simpler battery replacement. Surface finish: matt Housing colour: pure white, similar to RAL 9010 Housing material: ABS plastic	8.20/II
	MN990006	Adapter frame for mounting wireless sensors of the Berlin 1000 series in flush-mounted sockets up to 80 x 80 mm	5.60/I
	VV000025	General features: alre frame 'Berlin' (neutral) for all flush-mounted room temperature sensors with a 50 x 50 mm cover Surface finish: glossy Housing colour: pure white, similar to RAL 9010 Housing material: PC plastic	4.80/I
	VV000048	Features: similar to JZ-090.900 but for all flush-mounted controllers in combination with 55 x 55 mm cover	4.80/I
	VV000010	General features: alre frame 'Berlin' (neutral) for all flush-mounted room temperature sensors with a 50 x 50 mm cover Surface finish: glossy Housing colour: pearl white, similar to RAL 1013 Housing material: PC plastic	4.80/I
	MA990000	General features: Adjusting knob for B1000 series devices, Scale: degrees Celsius, pure white glossy	3.70/I

WIRELESS SYSTEMS – SENSORS

ILLUSTRATIONS

'Berlin 1000'

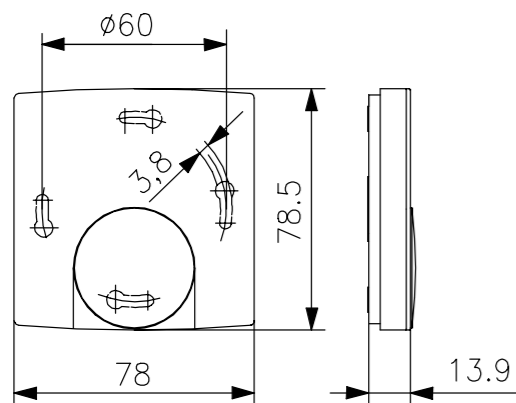

'Berlin 3000'

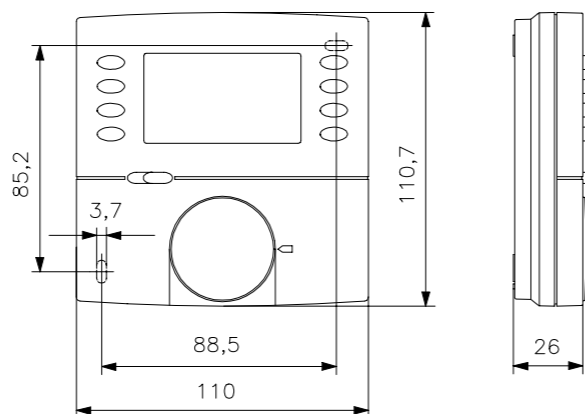

FTRFUd with alre frame 'Berlin'

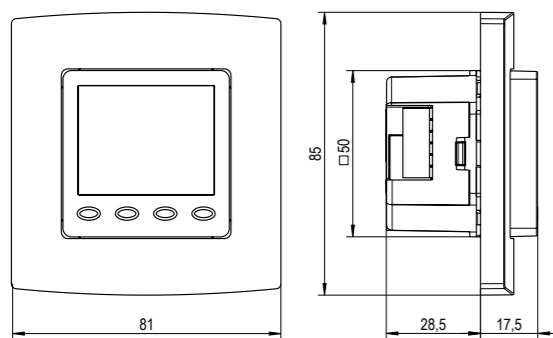

FTRFUd

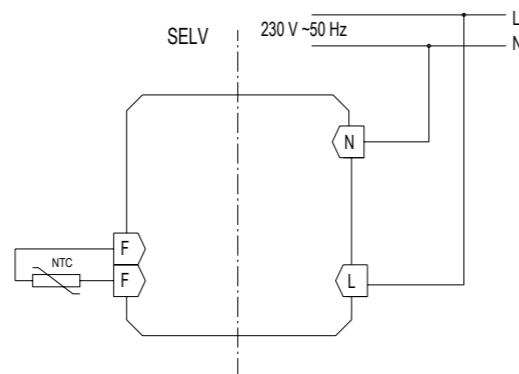

ADAPTATION OF ALRE FTRFUd-210.123

MANUFACTURER	RANGE	COLOUR RAL 9010 (surface finish)	ADAPTATION in switch range (55 x 55) possible with...	'50 x 50' adaptation possible with... (insert frame from switch manufacturer required)
BERKER	S.1	polar white (matt)	FTRFUd-210.123#56	not required
BERKER	S.1	polar white (glossy)	FTRFUd-210.123#55	not required
BERKER	Arsys	polar white (glossy)		FTRFUd-210.123#07 + (1108 01 69)
BERKER	B.3	aluminium / polar white (matt)	FTRFUd-210.123#56	not required
BERKER	B.3	aluminium / polar white (glossy)	FTRFUd-210.123#55	not required
BERKER	B.7	glass / polar white (matt)	FTRFUd-210.123#56	not required
BERKER	B.7	glass / polar white (glossy)	FTRFUd-210.123#55	not required
BERKER	K.1	polar white (glossy)		FTRFUd-210.123#07 + (1108 71 09)
BUSCH-JAEGER	Reflex SI / SI Linear	alpine white (glossy)	FTRFUd-210.123#28	not required
BUSCH-JAEGER	Busch-balance SI	alpine white (glossy)	FTRFUd-210.123#55	not required
BUSCH-JAEGER	impuls	alpine white (glossy)		FTRFUd-210.123#07 + (1746 / 10-74)
BUSCH-JAEGER	solo / future / axcent etc.	studio white – see RAL 9016 below		
Elso	Joy	pure white (glossy)	FTRFUd-210.123#55	not required
Elso	Fashion / Riva / Scala	pure white (glossy)		FTRFUd-210.123#07 + 203084
GIRA	surface switch	pure white (glossy)		FTRFUd-210.123#07 + (0282 112)
GIRA (System 55)	Standard / E2	pure white (semi-gloss)	FTRFUd-210.123#56	not required
GIRA (System 55)	Standard / E2 / E3	pure white (glossy)	FTRFUd-210.123#55	not required
GIRA (System 55)	E22	pure white (glossy)	FTRFUd-210.123#55	not required
GIRA (System 55)	Event	pure white (semi-gloss) + opaque...	FTRFUd-210.123#56	not required
GIRA (System 55)	Event	pure white (glossy) + opaque...	FTRFUd-210.123#55	not required
GIRA (System 55)	Esprit	pure white (semi-gloss) + glass, aluminium...	FTRFUd-210.123#56	not required
GIRA (System 55)	Esprit	pure white (glossy) + glass, aluminium...	FTRFUd-210.123#55	not required
GIRA	S-Color	pure white (high-gloss)		FTRFUd-210.123#07 + (0282 40)
JUNG	CD 500 / CD plus	alpine white (glossy)		FTRFUd-210.123#07 + (CD 590 Z WW)
JUNG	A 500 / A 550 / AS 500 / A plus / A flow	alpine white (glossy)	FTRFUd-210.123#55	not required
JUNG	LS 990	alpine white (glossy)		FTRFUd-210.123#07 + (LS 961 Z WW)
JUNG	LS plus	alpine white (glass)		FTRFUd-210.123#07 + (LS 961 Z WW)
JUNG	A creation	alpine white (glossy)	FTRFUd-210.123#55	not required
JUNG	LS Design	alpine white (glossy)		FTRFUd-210.123#07 + (LS 961 Z WW)
MERTEN (System M)	M-Smart, M-Plan, M-Pure	polar white (matt)	FTRFUd-210.123#56	not required
MERTEN (System M)	M-Smart, M-Plan, M-Creativ, M-Pure	polar white (glossy)	FTRFUd-210.123#55	not required
MERTEN (System Basis)	1-M / Atelier-M	polar white (glossy)	FTRFUd-210.123#55	not required
MERTEN (Surface System)	Artec / Antik	polar white (glossy)		FTRFUd-210.123#07 + (5160 99)
MERTEN	1-M / M-Smart / M-Plan / M-Pure / D-Life etc.	active white – see RAL 9016 below		
PEHA	Standard	pure white (glossy)		FTRFUd-210.123#07 + (80.670.02 ZV)
PEHA	Dialog	pure white (glossy)		FTRFUd-210.123#07 + (95.670.02 ZV)
PEHA	Aura	pure white (matt) / glass		FTRFUd-210.123#07 + (20.670.02 ZV)
PEHA	Badora	pure white (glossy)		FTRFUd-210.123#07 + (11.670.02 ZV)

MANUFACTURER	RANGE	COLOUR RAL 9016 (surface finish)	ADAPTATION in switch range (55 x 55) possible with...	'50 x 50' adaptation possible with... (insert frame from switch manufacturer required)
BUSCH-JAEGER	solo / future / future linear	studio white (RAL 9016, glossy)		FTRFUd-210.123#27 + (1746 / 10-84)
BUSCH-JAEGER	axcent	studio white (RAL 9016, glossy)		FTRFUd-210.123#27 + (1746 / 10-84)
BUSCH-JAEGER	carat (glass, bronze, gold)	studio white (RAL 9016, glossy)		FTRFUd-210.123#27 + (1746 / 10-84)
BUSCH-JAEGER	alpha (nea / exclusive *)	studio white (RAL 9016, glossy)		FTRFUd-210.123#27 + (1746 / 10-24G)
MERTEN	M-Smart, M-Plan, M-Pure	active white (RAL 9016, glossy)	FTRFUd-210.123#59	not required
MERTEN	1-M / Atelier-M	active white (RAL 9016, glossy)	FTRFUd-210.123#59	not required
MERTEN	D-Life	lotus white (similar to RAL 9016)		FTRFUd-210.123#27 + (MEG4500-6035)
PEHA	Standard	arctic		FTRFUd-210.123#27 + (D 80.670 ZV AW)

*) During assembly, you need to remove 4 plastic tabs located at the rear of the frame

NOTE: Most light switches are designed in the colour 'similar to RAL 9010', although different switch manufacturers use different designations for this colour. Coloured, glass and aluminium frames are also combined with white jacks or plugs so that controllers with white covers can also be integrated into these frames. Check the precise application in each individual case. The frames have different surface qualities (matt/glossy). For design reasons, the cover of the controller should have the same quality as the frame. We accept no liability for slight variations in colour and surface finish or for accuracy of fit. When installing devices into multi frames, always assemble the temperature controllers at the lowermost position.

'50 x 50 controller': The housing covers of the 50 x 50 controllers are 50 x 50 mm in size. Using a 50 x 50 mm insert frame, they can be integrated into nearly all light switch ranges in accordance with DIN 49075. The 50 x 50 mm insert frames must be ordered from the light switch manufacturer or from a wholesaler. The order number of the insert frame corresponding to the switch range in question can be found in the column 'For adaptation of '50 x 50' FTRFUd'.

'55 x 55 controller': The housing covers of the 55 x 55 controllers are 55 x 55 mm in size. Many light switch ranges have inner dimensions of 55 x 55 mm. Therefore, the 55 x 55 controllers can be installed directly in the light switch frame without the use of an insert frame. See the column 'Adaptation in switch range (55 x 55)' to determine whether the 55 x 55 controller fits in the given light switch range (FTRFUd-210.123#xx).

All information regarding switch manufacturers' product lines and item numbers was last updated in 12/2022 | No liability is assumed for the information provided. | Technical specifications subject to change.

WIRELESS SYSTEMS – ACTUATORS (HEATING)





TECHNICAL DATA



Surface finish:	matt
Permissible atmospheric humidity:	max. 95% rel. humidity, non-condensing
Control function:	heating
Hysteresis:	approx. 0.5 K
Radio frequency:	868.3 MHz
Safety and EMC:	according to DIN EN 60950-1, DIN EN 300220

APPLICATION







Wireless actuators (wireless heating controllers) which, in conjunction with alre wireless room temperature sensors, implement individual room temperature control. Primarily targets use in renovation applications or for heating system extensions.

TYPE/IMAGE	ITEM NO.	FEATURES	EURO/PG
	G8000422	<p>General features: 1-channel wireless temperature actuator for radiator valves; 'learning mode / battery discharged state' display; emergency mode; adapter for Danfoss RA, RAV, RAVL</p> <p>Housing colour: pure white, similar to RAL 9010</p> <p>Housing material: plastic</p> <p>Operating voltage: 2 x Mignon AA, 1.5 V. Do not use rechargeable batteries or lithium batteries!</p> <p>Ambient temperature: 0 to 50 °C</p> <p>Storage temperature: -20 to +50 °C</p> <p>Mounting / attachment: M30 x 1.5, included adapter for Danfoss RA, RAV, RAVL</p> <p>Protection rating: IP20</p> <p>Protection class: III</p> <p>Sensor: NTC internal (for emergency operation control)</p> <p>Nominal stroke: approx. 5 mm</p> <p>Nominal closing force: approx. 100 N</p> <p>Control range: 8 to 28 °C</p> <p>Display: Ready to mount / mechanical adjustment / mechanical adjustment error / loss of connection / learning mode</p> <p>Operating elements: learn button, installation button</p>	149.40 / I
	BA110500	<p>General features: 1-channel wireless temperature actuator; central control; emergency mode; 3000 W switching power for electrical direct heating systems, natural stone heating</p> <p>Design: Berlin 2000</p> <p>Housing colour: pure white, similar to RAL 9010</p> <p>Housing material: ABS plastic</p> <p>Operating voltage: 230 V AC, 50 Hz</p> <p>Ambient temperature: 0 to 40 °C</p> <p>Storage temperature: -20 to +70 °C</p> <p>Electrical connection: screw-type terminals 0.5–2.5 mm²</p> <p>Mounting / attachment: surface / wall mounting (4-hole assembly on flush-mounted socket)</p> <p>Protection rating: IP30</p> <p>Protection class: II for loads of protection classes I and II</p> <p>Max. switching current: 13 (2) A</p> <p>Max. switching voltage: 230 V AC, 50 Hz</p> <p>Min. switching voltage: 230 V AC, 50 Hz</p> <p>Switching power: 3000 W</p> <p>Switching element: relay</p> <p>Switching contact: NO contact</p> <p>Control range: 5 to 30 °C</p> <p>Display: installation mode / function check / connection loss / learning mode</p> <p>Operating elements: Learn button</p>	147.60 / I

WIRELESS SYSTEMS – ACTUATORS (HEATING)

TYPE/IMAGE	ITEM NO.	FEATURES	EURO/PG
	BA110201	<p>General features: 1-channel wireless temperature actuator; for activating an (electrical) floor heating system, the controller has a sensor input to which an optionally available remote sensor can be connected, which is then embedded in the floor. The following operating modes can be used in conjunction with such a sensor: floor temperature control function or room temperature control function with floor monitoring and direct or central setpoint temperature setting (central control); if the sensor is dispensed with, the HTFRU-110.124 works as a room temperature controller with direct or central setpoint temperature setting (central control); central control; emergency operation</p> <p>Housing colour: pure white, similar to RAL 9010</p> <p>Housing material: PC plastic</p> <p>Operating voltage: 230 V AC, 50 Hz</p> <p>Ambient temperature: -20 to +50 °C</p> <p>Storage temperature: -20 to +70 °C</p> <p>Electrical connection: screw-type terminals 0.5–1.5 mm²</p> <p>Mounting / attachment: in flush-mounted socket (deep flush-mounted socket recommended)</p> <p>Protection rating: IP20</p> <p>Protection class: II for loads of protection classes I and II</p> <p>Safety and EMC: according to DIN EN 60950-1, DIN EN 300220</p> <p>Max. switching current: 10 A to 30 °C ambient temperature</p> <p>Max. switching voltage: 230 V AC, 50 Hz; Min. switching voltage: 230 V AC, 50 Hz</p> <p>Switching power: 2300 W up to 30 °C ambient temperature</p> <p>Switching element: relay</p> <p>Switching contact: NO contact</p> <p>Control range: 5 to 30 °C</p> <p>Display: installation mode / function check / connection loss / learning mode</p> <p>Operating elements: Learn button</p>	201.50 / I
	BA121400	<p>General features: 4-channel radio temperature actuator for installation in the heating circuit manifold, max. 3 actuators per channel can be connected directly / max. 11 actuators in total, including pump module, one time zone per channel possible, master-slave operation, averaging with up to 8 measuring points. Upper part can be used to teach the wireless sensors (via channel selection teach-in button) in the individual rooms. Emergency operation: 4 fixing screws for wall mounting (see page 28 for implementation of central control using KTFRL)</p> <p>Housing colour: Upper part transparent, lower part anthracite grey, similar to RAL 7016</p> <p>Housing material: PC plastic</p> <p>Operating voltage: 230 V AC, 50 Hz</p> <p>Ambient temperature: -10 to +50 °C</p> <p>Storage temperature: -20 to +70 °C</p> <p>Electrical connection: spring-cage terminals 0.5–1.5 mm²</p> <p>Mounting / attachment: surface / wall-mounting</p> <p>Protection rating: IP20</p> <p>Protection class: II for loads of protection classes I and II</p> <p>Max. switching current: 3 (1) A</p> <p>Max. switching voltage: 230 V AC, 50 Hz Min. switching voltage: 230 V AC, 50 Hz</p> <p>Switching power: total 1150 W, of which 180 W for pump output</p> <p>Switching element: 5 relays</p> <p>Switching contact: 5 NO contacts</p> <p>Control range: 5 to 30 °C</p> <p>Display: installation mode, connection and status check, connection loss, learning mode are indicated per channel</p> <p>Operating elements: channel selection button, learning button</p>	323.70 / I
	BA121600	<p>General features: 8-channel radio temperature actuator for installation in the heating circuit manifold, max. 3 actuators per channel can be connected directly / max. 20 actuators in total, including pump module, one time zone per channel possible, master-slave operation, averaging with up to 8 measuring points; 4 fixing screws for wall mounting; installation mode, connection and status check, connection loss. Teach-in mode is displayed for each channel. Upper part can be used to teach-in the wireless sensors (via channel selection and teach-in button) in the individual rooms.</p> <p>Central control see page 28 using KTFRL)</p> <p>Housing colour: Upper part transparent, lower part anthracite grey, similar to RAL 7016</p> <p>Housing material: PC plastic</p> <p>Operating voltage: 230 V AC, 50 Hz</p> <p>Ambient temperature: -10 to +50 °C</p> <p>Storage temperature: -20 to +70 °C</p> <p>Electrical connection: spring-cage terminals 0.5–1.5 mm²</p> <p>Mounting / attachment: surface / wall-mounting</p> <p>Protection rating: IP20</p> <p>Protection class: II for loads of protection classes I and II</p> <p>Max. switching current: 3 (1) A</p> <p>Max. switching voltage: 230 V AC, 50 Hz; Min. switching voltage: 230 V AC, 50 Hz</p> <p>Switching power: total 1150 W, of which 180 W for pump output</p> <p>Switching element: 9 relays</p> <p>Switching contact: 9 NO contacts</p> <p>Control range: 5 to 30 °C</p> <p>Operating elements: channel selection button, learn button</p>	384.00 / I

WIRELESS SYSTEMS – ACTUATORS (HEATING)

TYPE/IMAGE	ITEM NO.	FEATURES	EURO/PG
	G8000370	General features: optional external floor sensor for HTFRU-110.124 Ambient temperature: -5 to +70 °C Protection rating: IP65 Sensor: NTC Connecting cable: 4 m, PVC	26.50/II
	G8000368	General features: optional external floor sensor for HTFRU-110.124 Ambient temperature: -5 to +70 °C Protection rating: IP65 Sensor: NTC Connecting cable: 6 m, PVC	29.50/II
WP-01	G9990180	General features: Heat conduction paste 2 ml; R > 1 TQ/cm, silicone-free Ambient temperature: -40 to +150 °C Heat conductivity: > 0.7 W/mK	7.70/II
	BN990005	General features: Magnet mounting set for terminal strips V00PL-216.176/V00PL-318.178 and radio multi-channel receiver HTFRL-214.240/HTFRL-316.225	19.30/II
	BN990003	General features: external antenna for reception enhancement of the multi-channel actuators under difficult reception conditions (antenna cable JZ-26 is not a part of the delivery scope) Design: Berlin 1000 Surface finish: glossy Housing colour: pure white, similar to RAL 9010 Housing material: ABS plastic Storage temperature: -20 to +70 °C Admissible humidity: max. 95% rel. humidity, non-condensing Protection rating: IP30	72.70/II
	BN990004	General features: Antenna cable for connecting the external antenna (JZ-25) with multi-channel actuators Connecting cable: 1 m	47.90/II
	C1809515	General features: Heat conduction paste 2 ml; R > 1 TQ/cm, silicone-free	45.00/II

suitable valve actuators, beginning on page 109

ILLUSTRATIONS

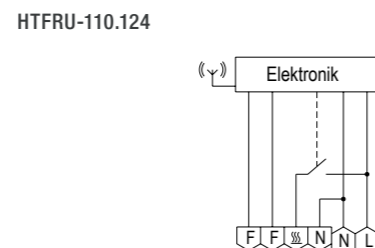
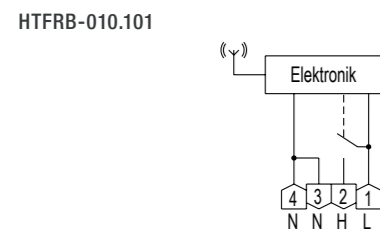
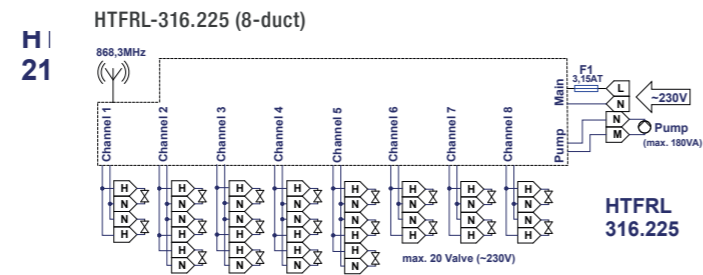
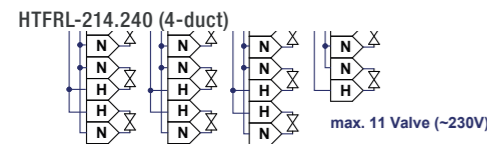

WIRELESS SYSTEMS – ACTUATORS (HEATING)

ILLUSTRATIONS

HTFMA-180.161

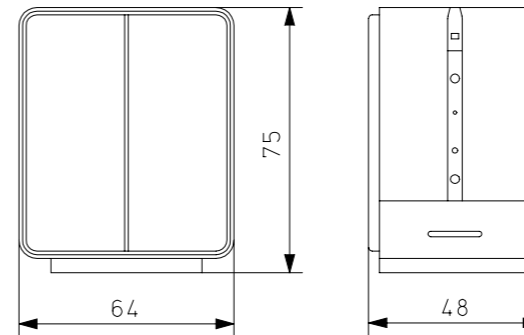

HTFRU-110.124

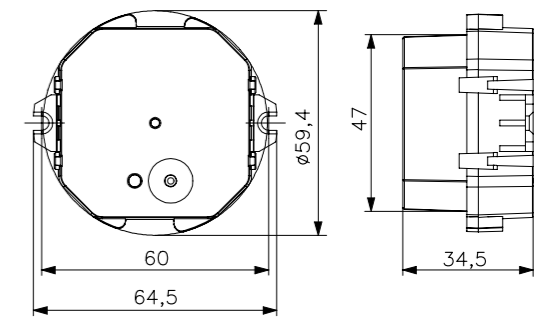

HTFRL-214.240

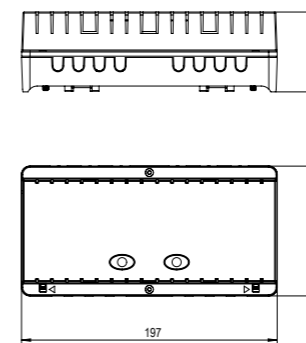

HTFRB-010.101

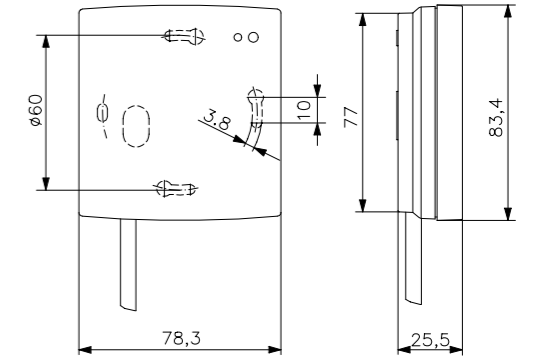

HTFRL-316.225

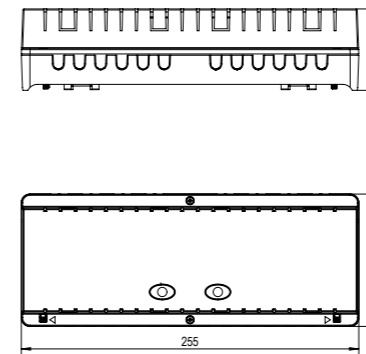

WIRELESS SYSTEMS – ACTUATORS (COOLING)



TECHNICAL DATA

Design:	'Berlin 2000'
Surface finish:	mat
Housing colour:	pure white, similar to RAL 9010
Housing material:	ABS plastic
Operating voltage:	230 V AC, 50 Hz
Ambient temperature:	-20 to +45 °C
Storage temperature:	-20 to +70 °C
Permissible atmospheric humidity:	max. 95% rel. humidity, non-condensing
Electrical connection:	screw-type terminals 0.5–2.5 mm ²
Mounting/attachment:	surface- / wall-mounting (4-hole assembly on flush-mounted socket)
Protection rating:	IP30
Protection class:	II for loads of protection classes I and II
Safety and EMC:	according to DIN EN 60950-1, DIN EN 300220
Average power consumption:	approx. 1.5 W
Max. switching current:	10 (2) A
Max./min. switching voltage:	230 V AC, 50 Hz
Switching power:	2300 W
Switching element:	relay
Switching contact:	NO contact
Output signal:	switching, 230 VAC, 50 Hz
Control range:	18 to 40 °C
Hysteresis:	approx. 0.5 K
Neutral zone:	approx. 3 K
Radio frequency:	868.3 MHz
General features:	Central control
Pipe system compatibility:	2-pipe
Operating elements:	Learn button

APPLICATION

The CTFRB was specifically designed to control electrothermal valve actuators (normally closed) and works together with alre wireless room temperature sensors to establish single-room temperature control.

TYPE/IMAGE	ITEM NO.	FEATURES	EURO/PG
CTFRB-010.101	BA110600	Control function: switches on the cooling if the setpoint value + neutral zone are exceeded, centra control, display 'Installation mode/Function check/Connection loss/Learning mode'	147.80 / I



Suitable valve actuators, beginning on page 109

ILLUSTRATIONS

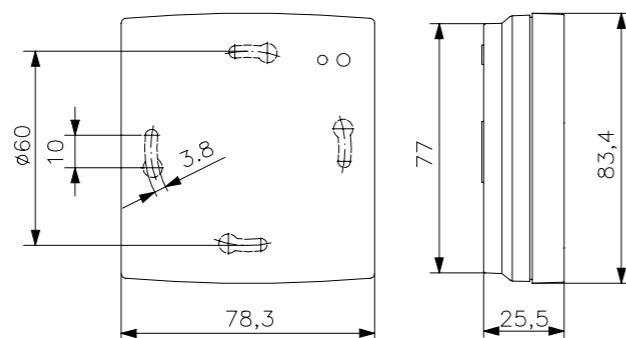
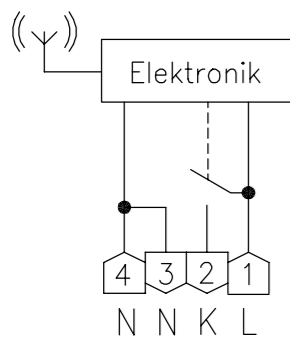

WIRELESS SYSTEMS – ACTUATORS (COOLING)

APPLICATION EXAMPLES (COMBINATION OPTIONS FOR SENSORS/ACTUATORS WITHOUT B@HOME GATE):

CTFRB for cooling operation, HTFRB for heating operation in a 4-pipe system

Room to be controlled

Averaging: (each actuator calculates the average value based on data from max. seven actual value sensors and a sensor with a setpoint adjuster)

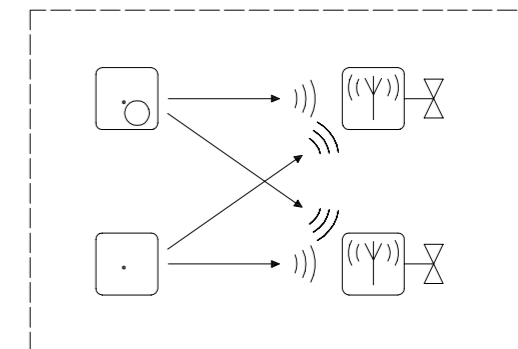

CTFRB for cooling operation, HTFRB for heating operation in a 4-pipe system

Room to be controlled

Master-slave operation: (comfort temperature through room sensor, scheduled ECO control, ON/OFF, holiday and party function in combination with a configured clock sensor)

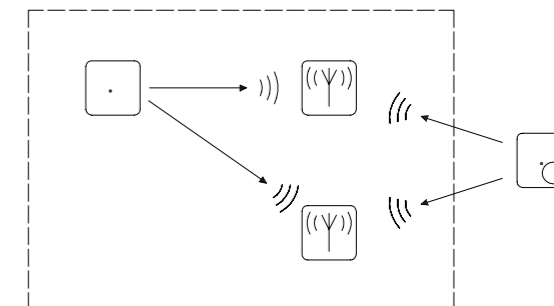

CTFRB for cooling operation, HTFRB for heating operation in a 4-pipe system

Room to be controlled

Centralised control: (one or optionally up to seven sensors without setpoint adjuster with any number of actuators; the target temperature is provided by an external sensor with setpoint adjuster)

Application: nurseries, guest accommodations, public offices and spaces

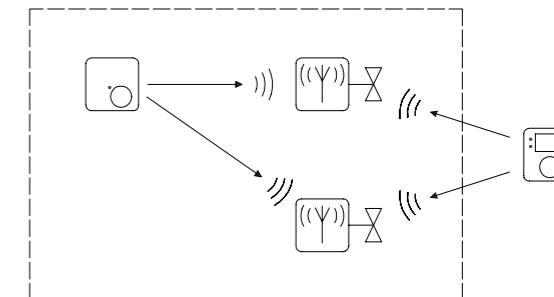

CTFRB for cooling operation, HTFRB for heating operation in a 4-pipe system

Room to be controlled

Application example: CTFRB controls the ceiling cooling system, HTFRB controls the underfloor heating system

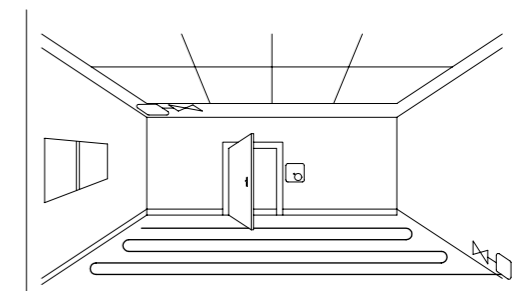

WIRELESS SYSTEMS – ACTUATORS (HEATING / COOLING)



TECHNICAL DATA



Surface finish:	matt
Housing colour:	light grey, similar to RAL 7035
Housing material:	ABS plastic
Operating voltage:	230 V AC, 50 Hz
Ambient temperature:	-10 to +50 °C
Storage temperature:	-20 to +70 °C
Permissible atmospheric humidity:	max. 95% rel. humidity, non-condensing
Electrical connection:	spring-cage terminals 0.5–1.5 mm ²
Mounting / attachment:	surface / wall mounting
Protection class:	II for loads of protection classes I and II
Safety and EMC:	according to DIN EN 60950-1, DIN EN 300220
Max. switching voltage:	230 V AC, 50 Hz
Min. switching voltage:	230 V AC, 50 Hz
Control function:	heating or cooling
Control range:	5 to 30 °C
Hysteresis:	approx. 0.5 K
Neutral zone:	adjustable 0–6 K
Radio frequency:	868.3 MHz
General features:	external dew point sensor; ECO function; operating mode 'off with frost protection monitoring'; central control; emergency operation mode
Factory setting:	neutral zone 0 K
Operating elements:	Duct selection button, learn button
Accessories:	suitable valve actuators: ZB00A-010.1xx optional magnetic mounting set for simple installation in heating manifold: JZ-24 external antenna: JZ-25 antenna cable 1 m: JZ-26
display	Installation mode, connection and status check, temperature below dew point, connection loss, learning mode are indicated per duct

APPLICATION

Wireless temperature controllers (actuators) used to implement a single-room climate control in conjunction with all wireless room temperature sensors.



Functions: heating, cooling with adjustable neutral zone; H/C changeover on site or via an external contact; on/off switching by contact with frost protection function; individual channels can be excluded from cooling operation; cooling interruption if condensation occurs, via dew point sensor or contact; cooling limit 18 °C; energy-saving function centrally via external timer or locally in master-slave operation, (max. 4/8 time zones possible, i.e., up to 4/8 sensors can be connected to clock); status display of the wireless connection for each channel, automatic emergency mode if connection lost;

The upper part can be removed for configuring the wireless sensors / channels in the individual rooms. The power supply is ensured during this time with a standard commercial 9-V block battery. The sensors can be configured easily using the channel selection button and a learn button. Attachment: There are 4 screws for wall attachment that are part of the standard kit; as an option, a magnetic attachment set JZ-24 for simple attachment in the heating manifold distribution cabinet can also be supplied.

TYPE/IMAGE	ITEM NO.	FEATURES	EURO/PG
	BA121500	Protection rating: IP 20 Max. switching current: output 1-4: 3 (1) A Pump output: 0.75 A* Total of all the outputs (4 channels + pump output): 3 (1) A Switching power: total 920 W, of which 180 W is pump output Switching element: 5 relays Switching contact: 5 NO contacts	380.30/1
	BA121700	Protection rating: IP 20 Max. switching current: output 1-8: 3 (1) A Pump output: 0.75 A* Total of all the outputs (8 channels + pump output): 3 (1) A Switching power: total 1380 W, of which 180 W is pump output Switching element: 9 relays Switching contact: 9 NO contacts	450.00/1

* Pump module included in scope of delivery

WIRELESS SYSTEMS – ACTUATORS (HEATING / COOLING)

TYPE/IMAGE	ITEM NO.	FEATURES	EURO/PG
	BN990002	General features: Magnetic mounting set for simple and safe mounting of the multi-channel actuators on a metallic substrate (for example heating manifold)	25.80 / II
	BN990003	General features: external antenna for reception enhancement of the multi-channel actuators under difficult reception conditions (antenna cable JZ-26 is not a part of the delivery scope) Design: Berlin 1000 Surface finish: glossy Housing colour: pure white, similar to RAL 9010 Housing material: ABS plastic Storage temperature: -20 to +70 °C Admissible humidity: max. 95% rel. humidity, non-condensing Protection rating: IP30	72.70 / II
	BN990004	General features: Antenna cable for connecting the external antenna (JZ-25) with multi-channel actuators Connecting cable: 1 m	47.90 / II

suitable valve actuators, beginning on page 109

ILLUSTRATIONS

KTFRL-213.140 (4-channel)

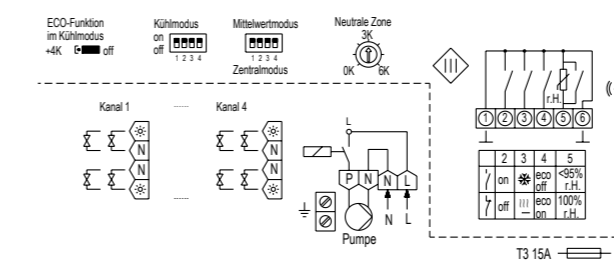

KTFRL-315.125 (8-channel)

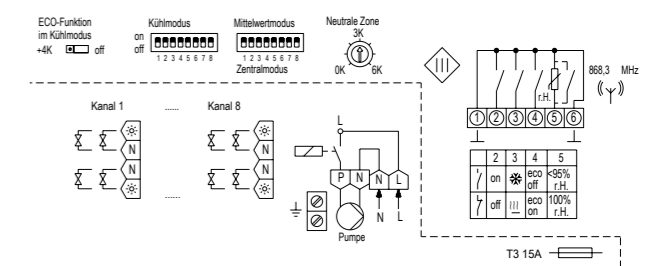

KTFRL-214.140

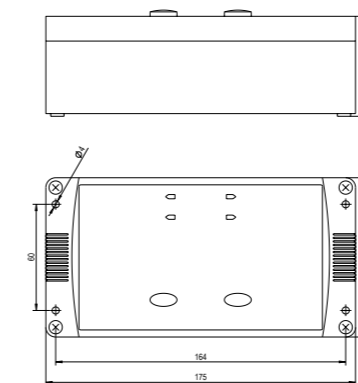

KTFRL-316.125

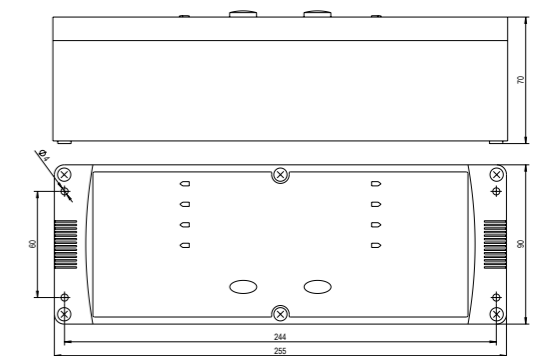



BUILDING AUTOMATION

INTELLIGENT AND FUTURE-PROOF



ALRE BUILDING AUTOMATION, ALWAYS **PERFECT** **INDOOR CLIMATE.**



OVERVIEW 32

SYSTEM INFORMATION	
General	34
Communication via BACnet MS/TP	36
Alre BACnet individual room controller connection options	38
alre BACnet individual room controller/ heating and cooling ceiling application example	40
Integration into various switch ranges	42
Overview BACnet room controller application	44
BACnet room controller KTRBUu	45
alre BACnet individual room controller adaptation	50

With our BACnet room controller – the only BACnet flush-mounted controller on the market – you control, regulate, monitor and optimise all central building functions such as heating, cooling or ventilation. The comfort in the building increases, the energy and operating costs decrease. According to predefined scenarios, all sensors, actuators, operating elements and other technical components in the building are networked with each other. This ensures that all components work together intelligently.

alre building automation:
BACnet controller for efficient building management systems.

APPLICATION EXAMPLES:

- + Hot water underfloor heating
- + Electric floor heating
- + Ceiling cassettes
- + Underfloor convectors
- + Heating and cooling ceilings
- + Duct devices



BACNET ROOM CONTROLLER, FLUSH-MOUNTED
KTRBUU217.456#21



BACNET ROOM CONTROLLER, FLUSH-MOUNTED
KTRBUU217.456#07



BACNET ROOM CONTROLLER, FLUSH-MOUNTED
KTRBUU217.456#56



BACNET ROOM CONTROLLER, FLUSH-MOUNTED
KTRBUU217.456#28

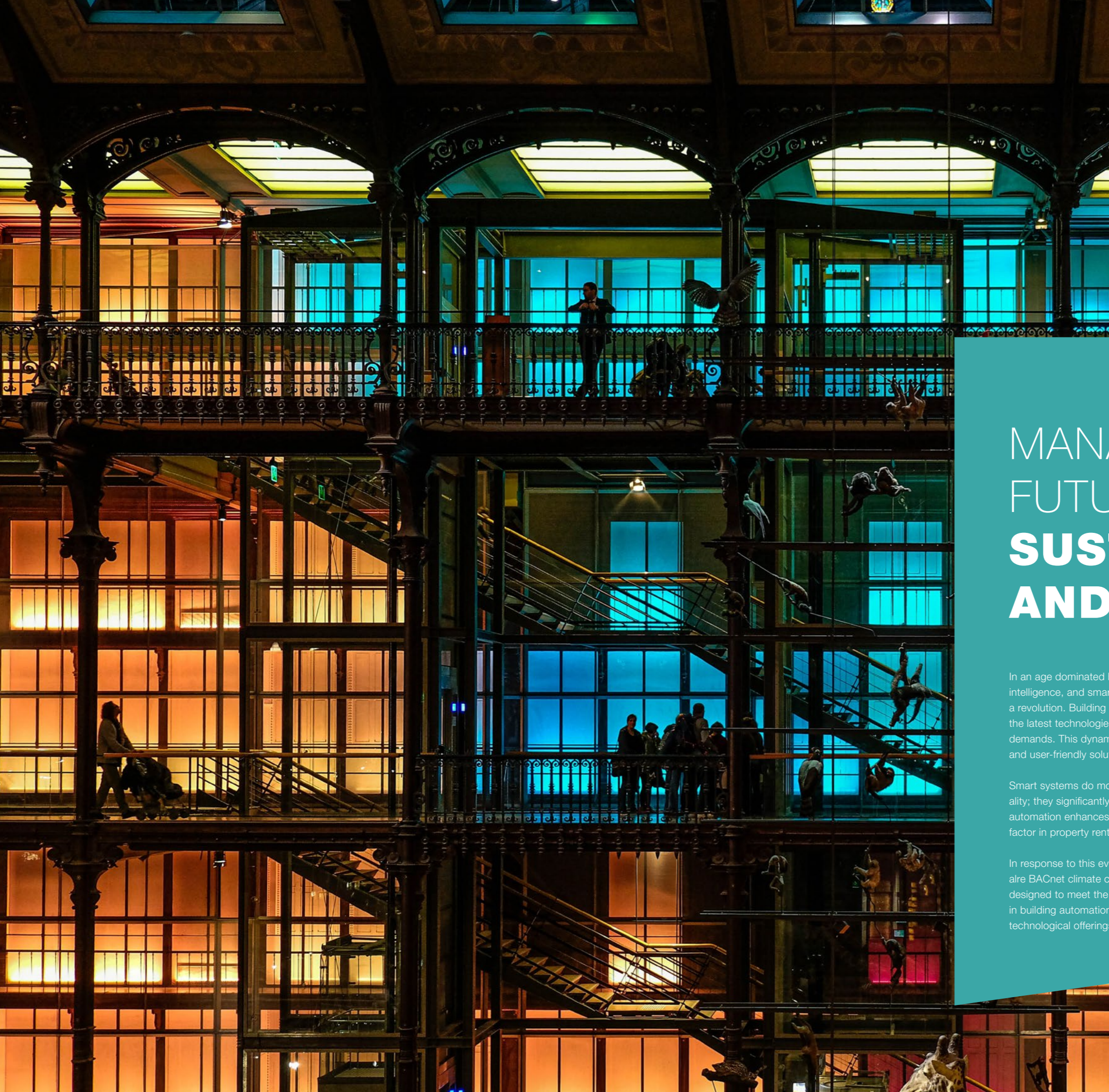

MANAGING THE FUTURE SAFELY – **SUSTAINABLY AND EFFICIENTLY**

In an age dominated by Industry 4.0, cloud computing, artificial intelligence, and smart living, digitalization is not just a trend – it's a revolution. Building automation is evolving rapidly, propelled by the latest technologies, interconnected systems, and escalating demands. This dynamic landscape necessitates intelligent, flexible, and user-friendly solutions.

Smart systems do more than just offer convenience and functionality; they significantly reduce operating costs. Modern building automation enhances property value, making it an increasingly vital factor in property rentals and sales.

In response to this evolution, we're excited to introduce the new alre BACnet climate controller. This innovative device is specifically designed to meet the unique demands of individual room control in building automation, marking a significant leap forward in our technological offerings.

COMMUNICATION VIA **BACNET MS/TP**

For building automation systems to fully leverage networked capabilities, it's essential for them to be interconnected and maintain an open communication framework. This is where open interfaces, like BACnet, play a pivotal role.

The alre BACnet room controller (KTRBUu 217.456) exemplifies seamless communication in this networked world. It operates in accordance with DIN EN ISO 16484-5 using the BACnet MS/TP network protocol. This ensures its compatibility with virtually all common building automation systems. Adhering to the 'B-AAC' (BACnet Advanced Application Controller) profile, it transcends the role of a mere setpoint generator.

A distinct advantage of the BACnet interface is its independence from additional gateways for implementation and communication at the management level, unlike other fieldbus interfaces like LON or KNX. This translates into significant cost savings, eliminating the need for service technicians with varied specializations for system commissioning. Additionally, by integrating the room control unit and individual room controller into a single device, it offers further cost efficiency compared to distributed solutions.



The BACnet individual room controller is therefore extremely versatile - in residential, office and business premises, in hotels, schools, hospitals and more.

The BACnet room controller has been awarded the BTL certificate for compliance with the BACnet standard ISO 16484-5, which has been proven by means of a BTL compliance test.

YOUR **ADVANTAGES** FOR ALL FIELDS OF APPLICATION:

- + Individual room controller with controller function (B-AAC)
- + Flush-mounted - integration in all common switch ranges (50 mm / 55 mm / 60 mm)
- + Selectable application for various user applications
- + Cost benefit for investment and commissioning
- + No additional gateways required (BACnet MS/TP)
- + Reduction of installation and operating costs



RESIDENTIAL



HOTEL

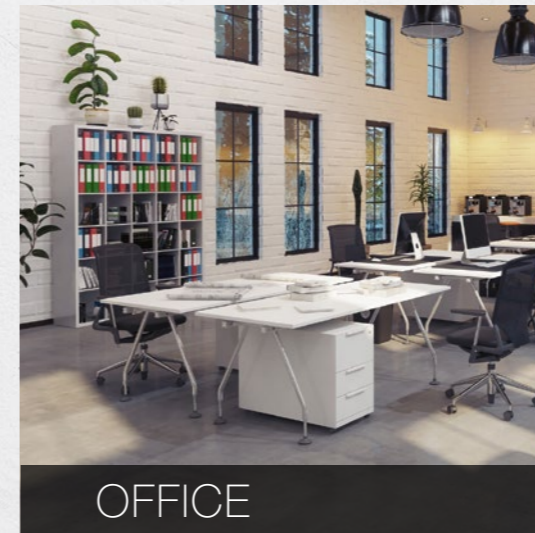

OFFICE



SCHOOLS



HOSPITAL



INDUSTRY

ALRE BACNET

INDIVIDUAL ROOM

CONTROLLER

CONNECTION OPTIONS

Designed for both 2 and 4-pipe systems, the alre BACnet room controller with a graphic display is a practical solution for managing time-dependent heating and cooling operations. Its design focuses on simplicity and effectiveness, fitting seamlessly into various building environments.

This controller features two inputs and three outputs, offering a good balance of control and functionality. The outputs include two for switching relays, supporting up to 5 actuators each, and an analogue output (0-10 V) suitable for applications like EC fan control.

For connectivity, the device uses one input specifically for BACnet communication, ensuring easy integration into building networks. The other input is configurable, allowing for the connection of different types of sensors, such as those for temperature or dew point. The system also supports the connection of windows or presence contacts through BACnet, providing a straightforward approach to building automation.

TECHNICAL HIGHLIGHTS AND FEATURES

- + Internal temperature sensor
- + Connectible external temperature sensor
- + Connectible external dew point sensor
- + MS/TP interface
- + 0-10 V EC fan coil
- + I/O mix integrated in device
- + 6-way valve

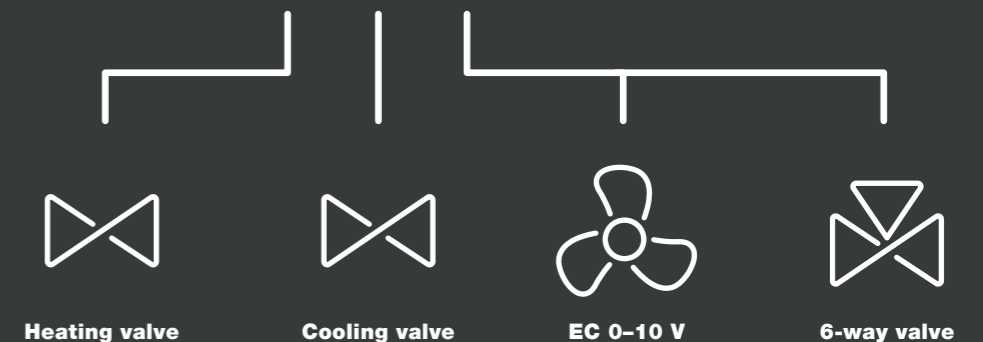
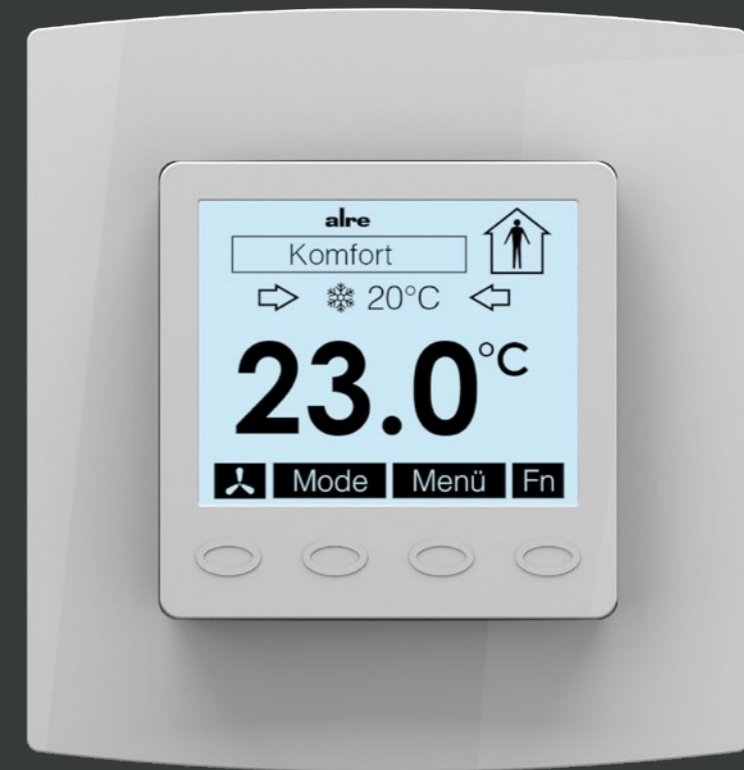
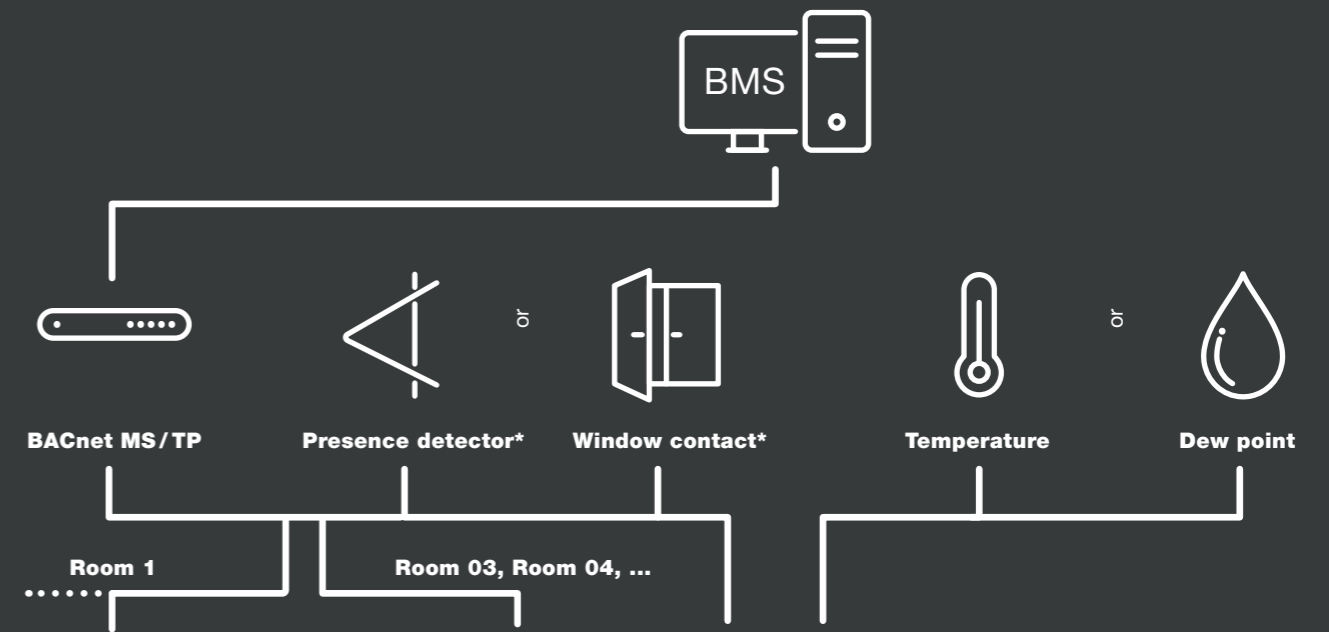

* depending on existing application

ALRE BACNET INDIVIDUAL ROOM CONTROLLER / HEATING AND COOLING CEILING APPLICATION EXAMPLE

Architects and planners often choose heating and cooling ceilings for air conditioning in buildings, valuing their ability to provide comfort without the drawbacks of draughts or noise. In line with these preferences, the alre BACnet individual room controller (KTRBUu 217.456) comes with pre-configured system diagrams, supporting a wide range of common air conditioning applications.

Particularly, the 'cooling and heating ceiling in 4-pipe system' setup is adept at managing heating and cooling valves. It vigilantly monitors the dew point to prevent condensation, automatically halting cooling operations if any condensation risk arises.

The operating parameters of the BACnet individual room controller are typically set by the building management system. However, in the event of a system failure, this controller is designed to continue functioning independently, maintaining consistent control over the room's environment.

SURFACE HEATING AND COOLING



UNDER FLOOR CONVECTION



CEILING CASSETTES



CHANNEL DEVICE



SUITABLE FOR ALL CURRENT SWITCH RANGES

The alre BACnet individual room controller is mounted in a flush-mounted socket. The housing fits exactly into design frames of sizes 50 x 50 mm, 55 x 55 mm and 60 x 60 mm from surface switch ranges of well-known manufacturers such as Berker, Busch-Jaeger, Gira, Jung, Merten, Peha, Hager or Feller (CH).



Check out the product video now!



KTRBUu 217.456 in
BERKER S.1



KTRBUu 217.456 in
BUSCH-JAEGER balance SI



KTRBUu 217.456 in
GIRA Standard 55



KTRBUu 217.456 in
JUNG AS 500



KTRBUu 217.456 in
MERTEN 1-M

INTEGRATION EXAMPLES

of the BACnet individual room controller in switch ranges from various manufacturers.

All variants also fit in multiple frames from all well-known manufacturers. Special colours such as anthracite and aluminium are available depending on the project.

OVERVIEW BACNET ROOM CONTROLLER APPLICATION

2 = 2-pipe system
 4 = 4-pipe system
 RA = Radiator
 FB = Floor temperature control
 KD = Ceiling temperature control
 UK = Underfloor convector
 HR = Heating coil
 KR = Cooling coil

TYPE	APPLICATION
2-pipe system underfloor heating with screed temperature sensor	2FB001
2-pipe system underfloor heating with limiter	2FB002
2-pipe system cooling/heating ceiling with dew point monitor	2KD001
2-pipe system heating/cooling coil with fan and supply air temperature	2HRKR001
2-pipe system with radiator with external room temperature sensor	2RA001
4-pipe system radiator (heating), cooling ceiling with dew point monitor	4RAKD001
4-pipe system radiator, cooling coil with fan and supply air temperature limitation*	4RAKR001
2-pipe system underfloor convector with room temperature sensor and fan	2UK001
4-pipe system floor temperature control with temperature limiter	4FB001
4-pipe system cooling/heating ceiling with dew point monitor and 6-way ball valve	4KD001
4-pipe system cooling/heating ceiling with dew point monitor and VAV	4KD002
4-pipe system cooling/heating ceiling with dew point monitor	4KD003
4-pipe system heating and cooling coil with fan and supply air temperature	4HRKR001
4-pipe system underfloor convector with dew point monitor and fan	4UK001

SYSTEMS								EXT. SENSORS					ACTUATORS					
2-pipe system	4-pipe system	Radiator	Floor temperature control	Ceiling temperature control	Underfloor convector	Heating coil	Cooling coil	TP Dew point sensor	TB Temperature limiter	Supply air temperature	Room air temperature	Floor screed temperature	Fan 0-10 V	VAV 0-10 V	Heating valve	Cooling valve	Heating/cooling valve	6-way ball valve 0-10V
•			•						•			•			•			
•			•						•						•			
•				•				•									•	
•	•									•			•				•	
	•	•		•				•							•		•	
	•	•							•				•		•		•	
•					•						•		•				•	
	•		•					•							•		•	
	•			•				•										•
	•							•					•		•		•	
	•				•			•					•		•		•	

BACNET ROOM CONTROLLER KTRBUU FLUSH-MOUNTED INSTALLATION – DESIGN BERLIN FLUSH-MOUNTED



TECHNICAL DATA

Design: Berlin flush-mounted
Housing material: PC, PMMA, ABS plastic
Operating voltage: 230 V AC, 50 Hz
Ambient temperature: 0 to 40 °C
Storage temperature: -20 to +70 °C
Permissible atmospheric humidity: max. 95% rel. humidity, non-condensing
Electrical connection: pluggable screw terminals
 Mains voltage side 0.75–2.5 mm²
 low voltage side 0.08–1.5 mm²
Mounting/attachment: In flush-mounted socket – can be adapted to fit virtually any switch range (deep flush-mounted socket recommended) see adaptation list on page 50
Protection rating: IP30
Protection class: II
Safety and EMC: according to DIN EN 60730
Max. switching voltage: 230 V AC, 50 Hz
Min. switching voltage: 230 V AC, 50 Hz
Switching power: 690 W
Max. power consumption: approx. 1 W (2.2 VA)
Max. switching current: per 3 (0.5) A (max. 5 valve actuators per output)
Switching element: 2 relays
Switching contact: 2 NO contacts
Output signal: Switching heating, cooling, heating/cooling, analogue 0–10 V (5 mA) to control a speed-controlled fan
Sensor: internal NTC, optional external 'Sensor 2' * (NTC 47k), dew point sensor
Control range: 5 to 40 °C
Setting range: standard setting range for heating (5 to 30 °C), second setting range for cooling (18 to 40 °C)
Hysteresis: < 1 K
Display type: illuminated graphical display
Pipe system compatibility: 2-pipe and 4-pipe

APPLICATION





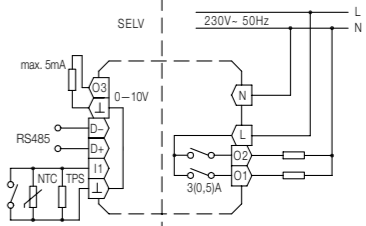



The alre BACnet individual room controller with graphic display was specially developed for time-dependent heating and cooling operation in 2 or 4-pipe systems. The controller can be used in a wide range of applications, such as hotels, residential, office and business premises as well as hospitals and schools.
 The communication takes place via BACnet according to DIN EN ISO 16484-5 with the BACnet MS/TP network protocol. The room controller is therefore compatible with all common building automation systems. The controller corresponds to the BACnet profile 'B-AAC' (BACnet Advanced Application Controller).
 The predefined applications cover a wide range of applications for room temperature control in room automation.
 Special colours such as anthracite and aluminium are available depending on the project.

TYPE/IMAGE	ITEM NO.	FEATURES	CIRCUIT DIAGRAM	EURO/PG
------------	----------	----------	-----------------	---------

	UA230000	Surface finish: glossy Housing colour: pure white, similar to RAL 9010 Scope of delivery: controller, 50 x 50 mm cover, pure white (similar to RAL 9010), glossy, alre frame 'Berlin'		480.90/1
---	----------	--	---	----------

* Depending on the selected system scheme, a menu setting can be used to select whether control should be based on the internal or external sensor. In the intermediate positions, if both sensors are used, a weighting is applied to the internal room sensor and the external temperature sensor. The weighting allows for compensation of different structural conditions such as large window areas or cardinal directions. For very slow controlled systems, it is recommended to assign a higher weighting to the temperature sensor than to the internal room sensor.





BACNET ROOM CONTROLLER KTRBUU FLUSH-MOUNTED INSTALLATION – DESIGN BERLIN FLUSH-MOUNTED

TYPE/IMAGE	ITEM NO.	FEATURES	CIRCUIT DIAGRAM	EURO/PG
	UA230002	Similar to KTRBUu217.456#21 but scope of delivery as follows: controller, 50 x 50 mm cover pure white (similar to RAL 9010), glossy , without frame		476.80 / I
	UA230003	Similar to KTRBUu217.456#21 but with delivery scope: controller, 50 x 50 mm cover pearl white (similar to RAL 1013), glossy , without frame		476.80 / I
	UA230004	Similar to KTRBUu217.456#21 but scope of delivery as follows: controller, 50 x 50 mm cover traffic / studio white (similar to RAL 9016), glossy , without frame		476.80 / I
	UA230007	Similar to KTRBUu217.456 but scope of delivery as follows: controller, cover suitable for BUS-CH-JAEGER Reflex SI / SI Linear pure white (similar to RAL 9010), glossy , without frame		478.50 / I
	UA230005	Similar to KTRBUu217.456#21 but scope of delivery as follows: controller, 55 x 55 mm cover pure white (similar to RAL 9010), glossy , without frame		478.50 / I
	UA230009	Similar to KTRBUu217.456#21 but scope of delivery as follows: controller, 55 x 55 mm cover pure white (similar to RAL 9010), mat without frame		478.50 / I
	UA230006	Similar to KTRBUu217.456#21 but scope of delivery as follows: controller, 55 x 55 mm cover pearl white (similar to RAL 1013), glossy , without frame		478.50 / I
	UA230008	Similar to KTRBUu217.456#21 but scope of delivery as follows: controller, 55 x 55 mm cover traffic / studio white (similar to RAL 9016), glossy , without frame		478.50 / I

BACNET ROOM CONTROLLER KTRBUU FLUSH-MOUNTED INSTALLATION – DESIGN BERLIN FLUSH-MOUNTED

ACCESSORIES	ITEM NO.	FEATURES	EURO/PG
	VV000025	Design: Berlin Surface finish: glossy Housing colour: pure white, similar to RAL 9010 Housing material: PC plastic General features: alre frame 'Berlin' (neutral) for all flush-mounted controllers with 50 x 50 mm cover	4.80 / I
	VV000048	Features: similar to JZ-090.900, but for all flush-mounted controllers with 55 x 55 mm cover	4.80 / I
	VV000010	Design: Berlin Surface finish: glossy Housing colour: pearl white, similar to RAL 1013 Housing material: PC plastic General features: alre frame 'Berlin' (neutral) for all flush-mounted controllers with 50 x 50 mm cover	4.80 / I
	G8000299	Dew point sensor to detect and report the dew point (see also 'Air conditioning technology' section, page 140) Mounting / attachment: using clips on cooling ceiling capillary pipe Use: drywall cooling ceiling (plasterboard) with hung up capillary tube mat, metal cooling ceiling with integrated capillary pipe system Sensor wire extendible up to: 50 m with 2 x 0.5 mm ² Scope of delivery: sensor, 2 clips for cooling pad	69.70 / I
	G8000300	Dew point sensor to detect and report the dew point (see also 'Air conditioning technology' section, page 140) Mounting / attachment: using clips on cooling ceiling capillary pipe or cable ties on the pipe Use: Pipe systems transporting cold water, plaster cooling ceiling with capillary tube system Sensor wire extendible up to: 50 m with 2 x 0.5 mm ² Scope of delivery: Sensor, 2 clips for cooling pad, 2 cable ties	69.70 / I
	SN120000	Dew point sensor to detect and report the dew point (see also 'Air conditioning technology' section, page 140) Mounting / attachment: attach to pipe by means of cable ties Use: piped cold-water systems Sensor wire extendible up to: 50 m with 2 x 0.5 mm ² Scope of delivery: Sensor, 2 cable ties	62.40 / I
	SA140014	Surface-mounted 'ultra-thin' room temperature sensor for temperature measurement in residential and business premises (see also 'Sensor technology' section, page 210) Mounting / attachment: surface / wall mounting (4-hole assembly on flush-mounted socket) Housing colour: pure white, similar to RAL 9010, glossy Housing material: ABS plastic Ambient temperature: -10 to +50 °C Admissible humidity: max. 95% rel. humidity, non-condensing Protection rating: IP30 Protection class: III Electrical connection: screw-type terminals 0.33 mm ² – 1.5 mm ²	30.10 / III
	SN090198	Flush-mounted room temperature sensor for temperature measurement in residential and business premises (see also 'Sensor technology' section, page 211) Mounting / attachment: in flush-mounted box – in almost all Surface switch ranges 50 x 50 mm adaptable Housing colour: pure white, similar to RAL 9010, glossy Housing material: PC plastic Ambient temperature: -10 to +50 °C Admissible humidity: max. 95% rel. humidity, non-condensing Protection rating: IP30 Protection class: III Electrical connection: Screw-type terminals 0.5 mm ² to 1.5 mm ²	38.10 / III

BACNET ROOM CONTROLLER KTRBUU FLUSH-MOUNTED INSTALLATION – DESIGN BERLIN FLUSH-MOUNTED

ACCESSORIES	ITEM NO.	FEATURES	EURO/PG
	G9040380	Temperature sensor for temperature measurement outdoors and in humid areas, special protection against dust and humidity (see also 'Sensor technology' section, page 216) Mounting / attachment: surface / wall mounting Housing colour: pure white, similar to RAL 9010 Housing material: PA plastic (30% GF reinforced) Ambient temperature: -30 to +70 °C Admissible humidity: max. 95% rel. humidity, non-condensing Protection rating: IP65 Protection class: III Electrical connection: Screw-type terminals 0.14 mm ² -2.5 mm ²	27.10 / III
	G9031446	Cable temperature sensor for temperature measurement / temperature limiting of the floor or supply air (see also 'Sensor technology' section, page 216) Mounting / attachment: in immersion sleeve, protection coil, on pipe, etc. Cable material / length: PE, 1.5 m Sensor sleeve material: V4A (1.4571) Ambient temperature: -35 to +100 °C Admissible humidity: max. 95% rel. humidity, non-condensing Protection rating: IP 67 Protection class: III Electrical connection: Safety extra low voltage only max. 30 V AC / 42 V DC	31.40 / III
	H9100010	Electro-thermal valve actuator (see also Heating / Air conditioning technology section) Mounting / attachment: M 30 x 1.5 Housing colour: pure white, similar to RAL 9010 Housing material: PC plastic, GF (20%) Operating voltage: 230 V~, 50 Hz Max. power consumption: 70 W Max. starting current: approx. 0.3 A Ambient temperature: 0 to 50 °C Storage temperature: -20 to +70 °C Admissible humidity: max. 95% rel. humidity, non-condensing Protection rating: IP42 Protection class: II Average power consumption: approx. 3 W Opening / closing time: approx. 4 min Nominal stroke: 3 mm Function type: normally closed Nominal closing force: 90 N Connecting cable: 0.8 m / 2 x 0.5 mm ²	33.80 / I
	G8990010	Electrothermal valve actuator for fully automatic hydraulic balancing Mounting / attachment: M 30 x 1.5 Housing colour: grey-orange Housing material: PA6 plastic Operating voltage: 230 V~, 50 Hz Max. power consumption: 30 W Max. starting current: approx. 0.13 A Ambient temperature: 0 to 50 °C Storage temperature: -25 to +60 °C Admissible humidity: max. 95% rel. humidity, non-condensing Protection rating: IP42 Protection class: II Average power consumption: 1.7 W Opening / closing time: approx. 3 min Nominal stroke: 3.5 mm Function type: normally closed Nominal closing force: 110 N Connecting cable: 1 m / 2 x 0.34 mm ²	86.40 / I

BACNET ROOM CONTROLLER KTRBUU FLUSH-MOUNTED INSTALLATION – DESIGN BERLIN FLUSH-MOUNTED

ILLUSTRATIONS

KTRBUu with alre frame 'Berlin'



Pluggable screw-type terminals

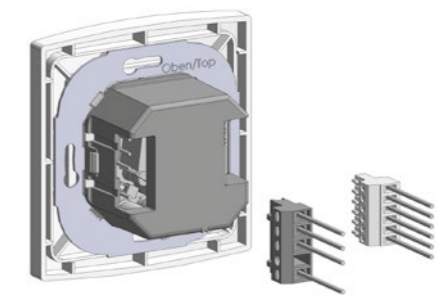

KTRBUu with alre frame 'Berlin'

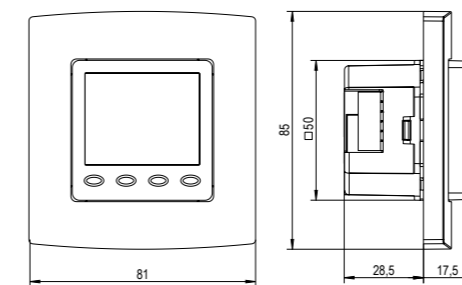



ALRE BACNET INDIVIDUAL ROOM CONTROLLER ADAPTATION

KTRBUU217.456 – FLUSH-MOUNTED

MANUFACTURER	RANGE	COLOUR RAL 9010 (surface finish)	ADAPTATION in switch range (55 x 55) possible with...	'50 X 50' adaptation possible with... (insert frame from manufacturer required)
BERKER	S.1	polar white (matt)	KTRBUu217.456#56	not required
BERKER	S.1	polar white (glossy)	KTRBUu217.456#55	not required
BERKER	Arsys	polar white (glossy)		KTRBUu217.456#07 + 1108 01 69
BERKER	B.3	aluminium / polar white (matt)	KTRBUu217.456#56	not required
BERKER	B.3	aluminium / polar white (glossy)	KTRBUu217.456#55	not required
BERKER	B.7	glass / polar white (matt)	KTRBUu217.456#56	not required
BERKER	B.7	glass / polar white (glossy)	KTRBUu217.456#55	not required
BERKER	K.1	polar white (glossy)		KTRBUu217.456#07 + 1108 71 09
BUSCH-JAEGER	Reflex SI/SI Linear	alpine white (glossy)	KTRBUu217.456#28	not required
BUSCH-JAEGER	Busch-balance SI	alpine white (glossy)	KTRBUu217.456#55	not required
BUSCH-JAEGER	impuls	alpine white (glossy)		KTRBUu217.456#07 + 1746/10-74
BUSCH-JAEGER	solo / future / axcent etc.	studio white – see RAL 9016 below		
Elso	Joy	pure white (glossy)	KTRBUu217.456#55	not required
Elso	Fashion / Riva / Scala	pure white (glossy)		KTRBUu217.456#07 + (203084)
GIRA	surface switch	pure white (glossy)		KTRBUu217.456#07 + 0282 112
GIRA (System 55)	Standard / E2	pure white (semi-gloss)	KTRBUu217.456#56	not required
GIRA (System 55)	Standard / E2 / E3	pure white (glossy)	KTRBUu217.456#55	not required
GIRA (System 55)	E22	pure white (glossy)	KTRBUu217.456#55	not required
GIRA (System 55)	Event	pure white (semi-gloss) + opaque...	KTRBUu217.456#56	not required
GIRA (System 55)	Event	pure white (glossy) + opaque...	KTRBUu217.456#55	not required
GIRA (System 55)	Esprit	pure white (semi-gloss) + glass, aluminium...	KTRBUu217.456#56	not required
GIRA (System 55)	Esprit	pure white (glossy) + glass, aluminium...	KTRBUu217.456#55	not required
GIRA	S-Color	pure white (high-gloss)		KTRBUu217.456#07 + 0282 40
JUNG	CD 500 / CD plus	alpine white (glossy)		KTRBUu217.456#07 + CD 590 Z WW
JUNG	A 500 / A 550 / AS 500 / A plus / A flow	alpine white (glossy)	KTRBUu217.456#55	not required
JUNG	LS 990	alpine white (glossy)		KTRBUu217.456#07 + LS 961 Z WW
JUNG	LS plus	alpine white (glass)		KTRBUu217.456#07 + LS 961 Z WW
JUNG	A creation	alpine white (glossy)	KTRBUu217.456#55	not required
JUNG	LS Design	alpine white (glossy)		KTRBUu217.456#07 + LS 961 Z WW
MERTEN (System M)	M-Smart, M-Plan, M-Pure	polar white (matt)	KTRBUu217.456#56	not required
MERTEN (System M)	M-Smart, M-Plan, M-Creativ, M-Pure	polar white (glossy)	KTRBUu217.456#55	not required
MERTEN (System Basis)	1-M / Atelier-M	polar white (glossy)	KTRBUu217.456#55	not required
MERTEN (Surface System)	Artec / Antik	polar white (glossy)		KTRBUu217.456#07 + 5160 99
MERTEN	1-M / M-Smart / M-Plan / M-Pure / D-Life	active white – see RAL 9016 below		
PEHA	Standard	pure white (glossy)		KTRBUu217.456#07 + 80.670.02 ZV
PEHA	Dialog	pure white (glossy)		KTRBUu217.456#07 + 95.670.02 ZV
PEHA	Aura	pure white (matt) / glass		KTRBUu217.456#07 + 20.670.02 ZV
PEHA	Badora	pure white (glossy)		KTRBUu217.456#07 + 11.670.02 ZV

MANUFACTURER	RANGE	COLOUR RAL 9016 (surface finish)	ADAPTATION in switch range (55 x 55) possible with...	To ADAPT KTRBUu size 50 x 50, an insert frame from the manufacturer is required
BUSCH-JAEGER	solo / future / future linear	studio white (RAL 9016, glossy)		KTRBUu217.456#27 + 1746 / 10-84
BUSCH-JAEGER	axcent	studio white (RAL 9016, glossy)		KTRBUu217.456#27 + 1746 / 10-84
BUSCH-JAEGER	carat (glass, bronze, gold)	studio white (RAL 9016)		KTRBUu217.456#27 + 1746 / 10-84
BUSCH-JAEGER	alpha (nea / exclusive *)	studio white (RAL 9016, glossy)		KTRBUu217.456#27 + 1746 / 10-24G
MERTEN	M-Smart, M-Plan, M-Pure	active white (RAL 9016, glossy)	KTRBUu217.456#59	not required
MERTEN	1-M / Atelier-M	active white (RAL 9016, glossy)	KTRBUu217.456#59	not required
Merten	D-Life	lotus white (RAL 9016)		KTRBUu217.456#27 + MEG4500-6035
PEHA	Standard	arctic		KTRBUu217.456#27 + D 80.670 ZV AW

*) During assembly, you need to remove 4 plastic tabs located at the rear of the frame.

NOTE: Most light switches are designed in the colour 'similar to RAL 9010', although different switch manufacturers use different designations for this colour. Coloured, glass and aluminium frames are also combined with white jacks or plugs so that controllers with white covers can also be integrated into these frames. Check the precise application in each individual case. The frames have different surface qualities (matt/glossy). For design reasons, the cover of the controller should have the same quality as the frame. We accept no liability for slight variations in colour and surface finish or for accuracy of fit. When installing devices into multi frames, always assemble the temperature controllers at the lowermost position.

'50 x 50 controller': The housing covers of the 50 x 50 controllers are 50 x 50 mm in size. Using a 50 x 50 mm insert frame, they can be integrated into nearly all light switch ranges in accordance with DIN 49075. The 50 x 50 mm insert frames must be ordered from the light switch manufacturer or from a wholesaler. The order number of the insert frame corresponding to the switch range in question can be found in the column 'For adaptation of '50 x 50' KTRBUu'.

'55 x 55 controller': The housing covers of the 55 x 55 controllers are 55 x 55 mm in size. Many light switch ranges have inner dimensions of 55 x 55 mm. Therefore, the 55 x 55 controllers can be installed directly in the light switch frame without the use of an insert frame. See the column 'Adaptation in switch range (55 x 55)' to determine whether the 55 x 55 controller fits in the given light switch range (KTRBUu217.456#xx).

All information regarding switch manufacturers' product lines and item numbers was last updated in 12/2022 | No liability is assumed for the information provided. | Technical specifications subject to change.



HEATING TECHNOLOGY

ENERGY-EFFICIENT AND TIMELESS



ALRE HEATING TECHNOLOGY, COMFORTABLE TEMPERATURE IN EVERY ROOM.



OVERVIEW

54

ROOM/FLOOR TEMPERATURE CONTROLLERS

Room temperature controller, bimetal (mechanical) 'surface-mounted'	59
Room temperature controller, bimetal (mechanical) 'surface-mounted ultra-slim'	65
Room temperature controller, bimetal (mechanical) 'surface-mounted or plug-in'	68
Room temperature controller, electronic, with clock 'surface-mounted'	70
Room temperature controller electronic with display "Surface-mounted ultra-slim"	72
Room temperature controller, bimetal (mechanical) 'flush-mounted'	73
Room temperature controller electronic 'flush-mounted'	90
Room or floor temperature controller, electronic, with clock 'flush-mounted'	92
Floor temperature or surface temperature controller, electronic 'surface-mounted'	96
Floor temperature controller, electronic, with clock 'surface-mounted'	98
Floor temperature controller, electronic, 'flush-mounted'	100

TERMINAL STRIPS FOR HEATING MANIFOLDS / VALVE ACTUATORS

Actuator 'STELLA' 230 V NC	108
Electro-thermal valve actuators	109
Terminal strip for heating manifold	110

Our heating technology products feature a wide range of thermostats, each tailored for specific needs and focused on energy efficiency. With configurable programs and display controllers, they ensure energy-efficient heating in various settings like offices, homes, hotels, and hospitals.

Choose from our ultra-slim surface-mounted thermostats known for their sleek design and durability, or opt for our flush-mounted thermostats, developed to fit any switch frame and available in various RAL colors to ensure perfect interior matching. Whatever your needs, our collection offers the right thermostat solution.

alre thermostats: designed and made in Germany for energy-efficient heating.

APPLICATION EXAMPLES:

- + Hot water underfloor heating
- + Electric underfloor heating systems
- + Natural stone heating systems
- + Night storage heating systems
- + Tiled stove heating systems
- + Partial air conditioners
- + Mobile radiators
- + Accessories such as terminal strips and actuators



ROOM TEMPERATURE CONTROLLER, SURFACE-MOUNTED, ULTRA-SLIM, RTBSB



ROOM TEMPERATURE CONTROLLER, MECHANICAL, RTBSU

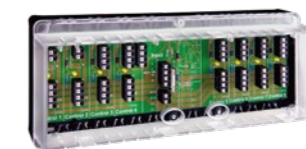

TERMINAL STRIP FOR HEATING MANIFOLD



ROOM TEMPERATURE CONTROLLER ELECTRONIC, HTRRUT



CONTROLLERS FOR ALL SWITCH RANGES

Integration examples in switch ranges with or without insert frame



ADAPTATION EXAMPLE BERKER (S.1)



ADAPTATION EXAMPLE JUNG (AS 500)



ADAPTATION EXAMPLE BUSCH-JAEGER (REFLEX SI LINEAR)



ADAPTATION EXAMPLE BERKER B.3 ALUMINIUM



ADAPTATION EXAMPLE GIRA (SURFACE SWITCH)



ADAPTATION EXAMPLE BERKER (K.1)

HEATING CONTROLLER OVERVIEW

TYPE	RTBSB-																HTRRBd-												
	001.000	001.002	001.010	001.026	001.045	001.048	001.062	001.065	001.086	001.096	001.110	001.202	001.500	001.910	001.910/2	001.948/1	201.000	201.002	201.010	201.034	201.062	201.065	201.202	201.500	001.401	001.411	210.100		
PAGE	59	59	60	60	60	61	61	61	62	62	62	62	62	63	63	64	65	65	66	66	66	66	66	67	68	69	72		
HOUSING DESIGN																													
Berlin 1000																	x	x	x	x	x	x	x	x				x	
Berlin 2000	x	x	x	x	x	x	x	x	x	x	x	x	x	x	x														
Berlin 3000																													
Berlin flush-mounted																													
Berlin 2000 with plug																									x	x			
SENSOR																													
Bimetal (NC contact)	x	x					x		x	x		x	x				x	x		x	x		x	x	x	x			
Bimetal (togglor)			x	x	x	x		x			x			x	x					x			x						
NTC, internal																													
NTC, external																													
NTC for floor monitoring																												x	
CONTROL TYPE																													
Heating controller	x	x	x*	x*	x*	x*	x	x*	x	x	x*	x	x	x*	x*	x*	x	x	x*	x	x	x*	x	x	x	x	x		x
Cooling function			x		x	x		x						x	x														
Fan output				x																									
Model with clock																													
PIPE SYSTEM																													
Air conditioning controller in 2-pipe system			x	x	x	x		x						x	x	x													
Air conditioning controller in 4-pipe system																													
APPLICATION																													
Natural stone heating																													
Tiled stove heating																													
Electric direct heating systems																													
Electric floor heating																													
Night storage heater																													
Hot water floor heating	x	x	x	x	x	x	x																					x	
Partial air conditioner			x	x	x	x		x																					
FEATURES																													
Output 'temperature reduction'																													
Input 'temperature reduction'		x																											
Switch "On / Off"																													
Switch 'Heating / Cooling'																													
Switch 'Heating / Off / Cooling'																													
Switch 'Reduction / Comfort / Automatic'																													
Switch 'auxiliary heating'																													
Display																													
Display with backlighting																													
Indicator lamp 'heating'																													
Indicator lamp 'reduction'																													
Indicator lamp 'auxiliary heating'																													
TECHNOLOGY																													
Control range -20 to +30 °C																													
Control range 5 to 30 °C	x	x	x	x																									
Control range 10 to 42 °C																													
Control range 10 to 50 °C																													
Control range 10 to 60 °C																													
Control range 20 to 80 °C																													
3000 W switching power internal setting																													
2-wire connection																													
24 V~																													
230 V~	x	x	x	x	x	x	x	x	x	x																			
24 V~ or 230 V~																													

x* Heating controllers using normally open valve actuators

HEATING CONTROLLER OVERVIEW

TYPE	RTBSU-															
	401.000	401.002	401.010	401.034	401.062	401.063	401.065	401.075	401.086	401.202	401.210	401.262	401.265	401.902		
PAGE	73	74	74	74	75	75	75	76	76	76	77	77	77	78		
HOUSING DESIGN																
Berlin 1000																
Berlin 2000																
Berlin 3000																
Berlin flush-mounted	x	x	x	x	x	x	x	x	x	x	x	x	x	x		
Berlin 2000 with plug																
SENSOR																
Bimetal (NC contact)	x	x			x	x	x		x	x	x		x	x		
Bimetal (togglor)			x													
NTC, internal																
NTC, external																
NTC for floor monitoring																
CONTROL TYPE																
Heating controller	x	x	x*	x	x	x	x*	x*	x	x	x*	x*	x	x		
Cooling function			x													
Fan output																
Model with clock																
PIPE SYSTEM																
Air conditioning controller in 2-pipe system			x						x	x			x	x		
Air conditioning controller in 4-pipe system																
APPLICATION																
Natural stone heating																
Tiled stove heating																
Electric direct heating systems																
Electric floor heating																
Night storage heater																
Hot water floor heating	x	x	x	x					x	x	x	x	x	x		
Partial air conditioner			x													
FEATURES																
Output 'temperature reduction'																
Input 'temperature reduction'		x							x				x	x		
Switch "On / Off"																
Switch 'Heating / Cooling'																
Switch 'Heating / Off / Cooling'																
Switch 'Reduction / Comfort / Automatic'																
Switch 'auxiliary heating'																
Display																
Display with backlighting																
Indicator lamp 'heating'																
Indicator lamp 'reduction'																
Indicator lamp 'auxiliary heating'																
TECHNOLOGY																
Control range -20 to +30 °C																
Control range 5 to 30 °C	x	x	x	x	x	x	x	x	x	x	x	x	x	x		
Control range 10 to 42 °C																
Control range 10 to 50 °C																
Control range 10 to 60 °C																
Control range 20 to 80 °C																
3000 W switching power internal setting																
2-wire connection																
24 V~																
230 V~	x	x	x	x	x	x	x	x	x	x	x	x	x	x		
24 V~ or 230 V~																

HEATING CONTROLLER OVERVIEW

TYPE	HTRRUt		HTRRUu		HTRRB-		HTRRBu-		RTERU-		FETR	
	210.A00#31	210.A00#55	210.021	011.010	011.410	110.021	110.117/21	010.715#21	010.715#00	101.700	101.715	101.716
PAGE	90		93	96	96	98	98	100	100	101	101	101
HOUSING DESIGN												
Berlin 1000												
Berlin 2000				x	x							
Berlin 3000						x	x					
Berlin flush-mounted	x	x	x					x	x	x	x	x
Berlin 2000 with plug												
SENSOR												
Bimetal (NC contact)												
Bimetal (togglor)												
NTC, internal	x	x	x				x					
NTC, external			x	x	x	x		x	x	x	x	x
NTC for floor monitoring			x									
CONTROL TYPE												
Heating controller	x	x	x	x	x	x	x	x	x	x	x	x
Cooling function												
Fan output												
Model with clock			x			x	x					
PIPE SYSTEM												
Air conditioning controller in 2-pipe system												
Air conditioning controller in 4-pipe system												
APPLICATION												
Natural stone heating			x				x					
Tiled stove heating						x						
Electric direct heating systems			x				x					
Electric floor heating			x	x		x		x	x	x	x	x
Night storage heater												
Hot water floor heating	x	x	x			x	x	x	x	x	x	x
Partial air conditioner												
FEATURES												
Output 'temperature reduction'							x	x				
Input 'temperature reduction'								x	x	x	x	x
Switch "On / Off"				x	x		x	x	x		x	x
Switch 'Heating / Cooling'												
Switch 'Heating / Off / Cooling'												
Switch 'Reduction / Comfort / Automatic'			x			x	x					
Switch 'auxiliary heating'												
Illuminated ring scale	x	x										
Display								x				
Display with backlighting			x			x						
Indicator lamp 'heating'			x					x	x	x	x	x
Indicator lamp 'reduction'										x	x	x
Indicator lamp 'auxiliary heating'												
TECHNOLOGY												
Control range -20 to +30 °C												
Control range 5 to 30 °C			x				x					
Control range 17 to 26 °C	x	x										
Control range 10 to 42 °C			x			x						x
Control range 10 to 50 °C								x	x		x	
Control range 10 to 60 °C					x					x		
Control range 20 to 80 °C						x						
3000 W switching power					x	x				x	x	x
internal setting										x		
2-wire connection												
24 V~												
230 V~	x	x	x	x	x	x	x	x	x	x	x	x
24 V~ or 230 V~												

ROOM TEMPERATURE CONTROLLER, MECHANICAL, RTBSB SURFACE-MOUNTED INSTALLATION – DESIGN BERLIN 2000



TECHNICAL DATA

Design:	Berlin 2000
Surface finish:	matt
Housing colour:	pure white, similar to RAL 9010
Housing material:	ABS plastic
Storage temperature:	-20 to +70 °C
Permissible atmospheric humidity:	Max. 95% rel. humidity, non-condensing
Electrical connection:	screw-type terminals 0.12 mm ² –2.5 mm ²
Mounting / attachment:	surface- / wall-mounting (4-hole assembly on flush-mounted socket)
Protection rating:	IP30
Safety and EMC:	according to DIN EN 60730
Average power consumption:	< 0.5 W
Switching element:	bimetallic contact
Sensor:	bimetal
General features:	thermal feedback

APPLICATION



Control or monitoring of temperatures in closed spaces. Suitable for all heating systems.

Valve actuator: normally closed. If normally open heating valves are available, they should be connected with the cooling output of the changeover switch (togglor).



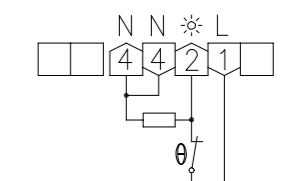

Up to a maximum of 10 actuators for valves can be connected (normally closed, NC); with a togglor, on the NO contact, up to 5 units (in this context, please check the switching capacity listed in the TECHNICAL DATA).

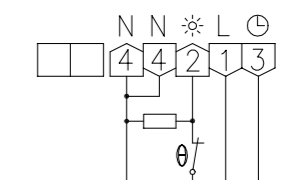
Installation note: Owing to the existing wiring space in the controller itself, installation on a flush-mounted socket is recommended, but it can also be performed on a plane, non-conducting substrate.



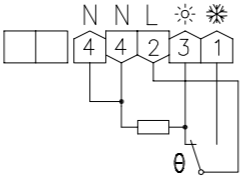

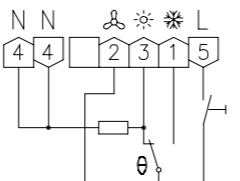

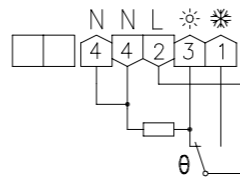
Explanations of technical terms can be found in the annex to the product catalogue or at www.alre.de.

TYPE/IMAGE	ITEM NO.	FEATURES	CIRCUIT DIAGRAM	EURO/PG
	MA010000	General features: Mechanical range limitation; scale: degrees Celsius; external setting Operating voltage: 230 VAC, 50 Hz Ambient temperature: 0 to 30 °C Protection class: II, if properly mounted Max. switching current: 10 (4) A Max. switching voltage: 230 VAC, 50 Hz Min. switching voltage: 230 VAC, 50 Hz Switching power: 2300 W Switching contact: NC contact (max. 10 actuators) Output signal: switching (230 VAC, 50 Hz) Control function: heating Control range: 5 to 30 °C Hysteresis: approx. 0.5 K at a temperature change of max. 4 K/h		40.30/1
	MA010011	Similar to RTBSB-001.000 but with multi-digit display 1 to 6		38.70/1
	MA010100	General features: ECO function; mechanical range limitation; scale: degrees Celsius; external setting Operating voltage: 230 VAC, 50 Hz Ambient temperature: 0 to 30 °C Protection class: II, if properly mounted Max. switching current: 10 (4) A Max. switching voltage: 230 VAC, 50 Hz Min. switching voltage: 230 VAC, 50 Hz Switching power: 2300 W Switching contact: NC contact (max. 10 actuators) Output signal: switching (230 VAC, 50 Hz) Control function: heating Control range: 5 to 30 °C Hysteresis: approx. 0.5 K at a temperature change of max. 4 K/h Input 'temperature reduction': approx. 4 K (230 VAC, 50 Hz)		42.80/1

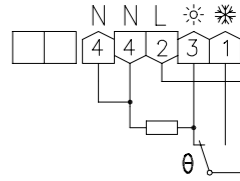

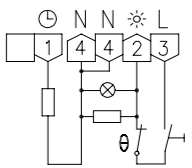

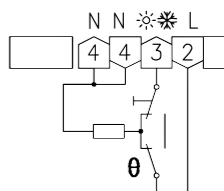

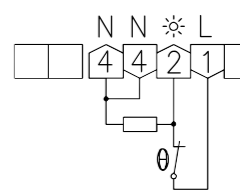
ROOM TEMPERATURE CONTROLLER, MECHANICAL, RTBSB SURFACE-MOUNTED INSTALLATION – DESIGN BERLIN 2000

TYPE/IMAGE	ITEM NO.	FEATURES	CIRCUIT DIAGRAM	EURO/PG
	MA010200	<p>General features: Mechanical range limitation; scale: degrees Celsius; external setting</p> <p>Operating voltage: 230 VAC, 50 Hz</p> <p>Ambient temperature: 0 to 30 °C</p> <p>Protection class: II, if properly mounted</p> <p>Max. switching current: heating (terminal 3) 10 (4) A, cooling (terminal 1) 5 (2) A</p> <p>Max. switching voltage: 230 VAC, 50 Hz</p> <p>Min. switching voltage: 230 VAC, 50 Hz</p> <p>Switching power: Terminal 3: 2300 W, terminal 1: 1150 W</p> <p>Switching contact: changeover switch (toggler, max. 10 actuators output terminal 3, max. 5 actuators output terminal 1)</p> <p>Output signal: switching (230 VAC, 50 Hz)</p> <p>Control function: heating or cooling</p> <p>Control range: 5 to 30 °C</p> <p>Hysteresis: approx. 0.5 K at a temperature change of max. 4 K/h</p>		51.10/I
	MA010900	<p>General features: mechanical range limitation; scale: degrees Celsius ; on / off switch; external setting</p> <p>Operating voltage: 230 VAC, 50 Hz</p> <p>Ambient temperature: 0 to 30 °C</p> <p>Protection class: II, if properly mounted</p> <p>Max. switching current: heating (terminal 3) 10 (4) A, cooling (terminal 1) 5 (2) A, fan (terminal 2) 5 (2) A</p> <p>Max. switching voltage: 230 VAC, 50 Hz</p> <p>Min. switching voltage: 230 VAC, 50 Hz</p> <p>Switching power: terminal 3: 2300 W, terminal 1: 1150 W, terminal 2: 1150 W</p> <p>Switching contact: changeover switch (toggler, max. 10 actuators output terminal 3, max. 5 actuators output terminal 1)</p> <p>Output signal: switching (230 VAC, 50 Hz); fan permanently operating (230 VAC, 50 Hz) if device has been switched on</p> <p>Control function: heating or cooling</p> <p>Control range: 5 to 30 °C</p> <p>Hysteresis: approx. 0.5 K at a temperature change of max. 4 K/h</p>		62.00/I
	MA011200	<p>General features: mechanical range limitation; scale: degrees Celsius ; external setting</p> <p>Operating voltage: 230 VAC, 50 Hz</p> <p>Ambient temperature: -20 to +30 °C</p> <p>Protection class: II, if properly mounted</p> <p>Max. switching current: heating (terminal 3) 10 (4) A, cooling (terminal 1) 5 (2) A</p> <p>Max. switching voltage: 230 VAC, 50 Hz</p> <p>Min. switching voltage: 230 VAC, 50 Hz</p> <p>Switching power: terminal 3: 2300 W, terminal 1: 1150 W</p> <p>Switching contact: changeover switch (toggler, max. 10 actuators output terminal 3, max. 5 actuators output terminal 1)</p> <p>Output signal: switching (230 VAC, 50 Hz)</p> <p>Control function: heating or cooling</p> <p>Control range: -20 to +30 °C</p> <p>Hysteresis: approx. 1.5 K at a temperature change of max. 4 K/h</p>		54.30/I

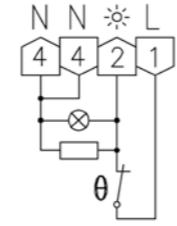

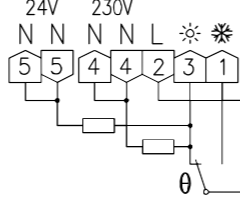
ROOM TEMPERATURE CONTROLLER, MECHANICAL, RTBSB SURFACE-MOUNTED INSTALLATION – DESIGN BERLIN 2000

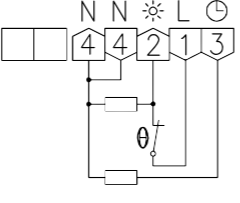
TYPE/IMAGE	ITEM NO.	FEATURES	CIRCUIT DIAGRAM	EURO/PG
	MA011300	<p>General features: Mechanical range limitation; scale: degrees Celsius; external setting</p> <p>Operating voltage: 230 VAC, 50 Hz</p> <p>Ambient temperature: 10 to 60 °C</p> <p>Protection class: II, if properly mounted</p> <p>Max. switching current: heating (terminal 3) 10 (4) A, cooling (terminal 1) 5 (2) A</p> <p>Max. switching voltage: 230 VAC, 50 Hz</p> <p>Min. switching voltage: 230 VAC, 50 Hz</p> <p>Switching power: terminal 3: 2300 W, terminal 1: 1150 W</p> <p>Switching contact: changeover switch (toggler, max. 10 actuators output terminal 3, max. 5 actuators output terminal 1)</p> <p>Output signal: switching (230 VAC, 50 Hz)</p> <p>Control function: heating or cooling</p> <p>Control range: 10 to 60 °C</p> <p>Hysteresis: approx. 1.5 K at a temperature change of max. 4 K/h</p>		54.30/I
	MA012400	<p>General features: ECO function; 'heating' display; mechanical range limitation; scale: degrees Celsius; on / off switch; external setting</p> <p>Input 'temperature reduction': approx. 4 K (230 VAC, 50 Hz)</p> <p>Operating voltage: 230 VAC, 50 Hz</p> <p>Ambient temperature: 0 to 30 °C</p> <p>Protection class: II, if properly mounted</p> <p>Max. switching current: 10 (4) A</p> <p>Max. switching voltage: 230 VAC, 50 Hz</p> <p>Min. switching voltage: 230 VAC, 50 Hz</p> <p>Switching power: 2300 W</p> <p>Switching contact: NC contact (max. 10 actuators)</p> <p>Output signal: heating, switching (230 VAC, 50 Hz)</p> <p>Control function: heating</p> <p>Control range: 5 to 30 °C</p> <p>Hysteresis: approx. 0.5 K at a temperature change of max. 4 K/h</p>		54.30/I
	MA010600	<p>General features: mechanical range limitation; scale: degrees Celsius; 'heating / cooling' switch; external setting</p> <p>Operating voltage: 230 VAC, 50 Hz</p> <p>Ambient temperature: 0 to 30 °C</p> <p>Protection class: II, if properly mounted</p> <p>Max. switching current: 5 (2) A</p> <p>Max. switching voltage: 230 VAC, 50 Hz</p> <p>Min. switching voltage: 230 VAC, 50 Hz</p> <p>Switching power: 1150 W</p> <p>Switching contact: Changeover switch (toggler, max. 5 actuators)</p> <p>Output signal: switching (230 VAC, 50 Hz)</p> <p>Control function: heating or cooling</p> <p>Control range: 5 to 30 °C</p> <p>Hysteresis: approx. 0.5 K at a temperature change of max. 4 K/h</p>		57.60/I
	MA010800	<p>General features: mechanical range limitation; 3000 W switching power, for electric direct heating systems, natural stone heating; multi-digit display 1–6; external setting</p> <p>Operating voltage: 230 VAC, 50 Hz</p> <p>Ambient temperature: 0 to 30 °C</p> <p>Protection class: II, if properly mounted</p> <p>Max. switching current: 13 (4) A</p> <p>Max. switching voltage: 230 VAC, 50 Hz</p> <p>Min. switching voltage: 230 VAC, 50 Hz</p> <p>Switching power: 3000 W</p> <p>Switching contact: NC contact</p> <p>Output signal: switching (230 VAC, 50 Hz)</p> <p>Control function: heating</p> <p>Control range: 5 to 30 °C</p> <p>Hysteresis: approx. 1 K at a temperature change of max. 4 K/h</p> <p>Accessories: can be combined with plug-in socket JZ-19</p>		45.00/I

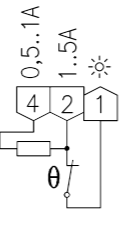
ROOM TEMPERATURE CONTROLLER, MECHANICAL, RTBSB SURFACE-MOUNTED INSTALLATION – DESIGN BERLIN 2000

TYPE/IMAGE	ITEM NO.	FEATURES	CIRCUIT DIAGRAM	EURO/PG
	MA012500	Similar to RTBSB-001.086, but with 'heating' display (LED red)		52.00/1
	MA012701	General features: Mechanical range limitation; scale: degrees Celsius; external setting Operating voltage: 230 VAC, 50 Hz or 24 VAC, 50 Hz Ambient temperature: 0 to 30 °C Protection class: II, if properly mounted; with 24 V, protection class III Max. switching current: heating (terminal 3) 230 VAC 10 (4) A or 24 VAC 2 (2) A, cooling (terminal 1) 5 (2) A or 24 VAC 2 (2) A Max. switching voltage: 230 VAC, 50 Hz Min. switching voltage: 24 VAC, 50 Hz Switching power: Terminal 3: 2300 W at 230 VAC, 48 W at 24 VAC, terminal 1: 1150 W at 230 VAC, 48 W at 24 VAC Switching contact: changeover switch (toggler, max. 5 actuators) Output signal: switching (230 VAC, 50 Hz or 24 VAC, 50 Hz) Output signal: cooling, switching (230 VAC, 50 Hz or 24 VAC, 50 Hz) Control function: heating or cooling Control range: 5 to 30 °C Hysteresis: approx. 0.5 K at a temperature change of max. 4 K/h		57.60/1
	MA011700	General features: ECO function; mechanical range limitation; scale: degrees Celsius; external setting Operating voltage: 24 VAC, 50 Hz Ambient temperature: 0 to 30 °C Protection class: III Max. switching current: 1 (1) A Max. switching voltage: 24 VAC, 50 Hz Min. switching voltage: 24 VAC, 50 Hz Switching power: 24 W Switching contact: NC contact (max. 5 actuators) Output signal: switching (24 VAC, 50 Hz) Control function: heating Control range: 5 to 30 °C Hysteresis: approx. 0.5 K at a temperature change of max. 4 K/h Input 'temperature reduction': approx. 4 K (24 VAC, 50 Hz)		50.70/1
	MA013401	General features: 2-wire room temperature controller; mechanical range limitation; multi-digit display *–6; external setting Operating voltage: 230 VAC, 50 Hz Ambient temperature: 0 to 30 °C Protection class: II, if properly mounted Max. switching current: 1 A or 5 A (see circuit diagram) Min. switching current: 0.5 A or 1 A (see circuit diagram) Min. switching voltage: 230 VAC, 50 Hz Min. switching voltage: 230 VAC, 50 Hz Switching power: 230 W or 1150 W (see circuit diagram) Switching contact: NC contact Output signal: switching (230 VAC, 50 Hz) Control function: heating Control range: 5 to 30 °C Hysteresis: approx. 1 K at a temperature change of max. 4 K/h (load-dependent)		44.50/1

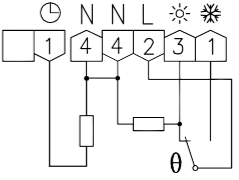
ROOM TEMPERATURE CONTROLLER, MECHANICAL, RTBSB SURFACE-MOUNTED INSTALLATION – DESIGN BERLIN 2000

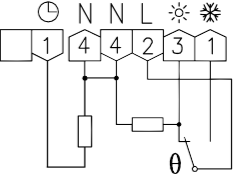
TYPE/IMAGE	ITEM NO.	FEATURES	CIRCUIT DIAGRAM	EURO/PG
	MA012000	General features: ECO function; scale: degrees Celsius; internal setting Operating voltage: 230 VAC, 50 Hz Ambient temperature: 0 to 30 °C Protection class: II, if properly mounted Max. switching current: heating (terminal 3) 10 (4) A, cooling (terminal 1) 5 (2) A Max. switching voltage: 230 VAC, 50 Hz Min. switching voltage: 230 VAC, 50 Hz Switching power: Terminal 3: 2300 W, terminal 1: 1150 W Switching contact: changeover switch (toggler, max. 10 actuators output terminal 3, max. 5 actuators output terminal 1) Output signal: switching (230 VAC, 50 Hz) Control function: heating or cooling Control range: 5 to 30 °C Hysteresis: approx. 0.5 K at a temperature change of max. 4 K/h Input 'temperature reduction': approx. 4 K (230 VAC, 50 Hz)		56.40/1
	MA012100	General features: ECO function; scale: degrees Celsius; internal setting Operating voltage: 24 VAC, 50 Hz Ambient temperature: 0 to 30 °C Protection class: III Max. switching current: 1 (1) A Max. switching voltage: 24 VAC, 50 Hz Min. switching voltage: 24 VAC, 50 Hz Switching power: 24 W Switching contact: changeover switch (toggler, max. 3 actuators) Output signal: switching (24 VAC, 50 Hz) Control function: heating or cooling Control range: 5 to 30 °C Hysteresis: approx. 0.5 K at a temperature change of max. 4 K/h Input 'temperature reduction': approx. 4 K (24 VAC, 50 Hz)		60.80/1

ROOM TEMPERATURE CONTROLLER, MECHANICAL, RTBSB SURFACE-MOUNTED INSTALLATION – DESIGN BERLIN 2000

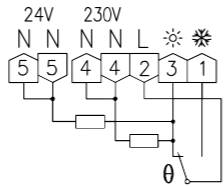
TYPE/IMAGE	ITEM NO.	FEATURES	CIRCUIT DIAGRAM	EURO/PG
	MA012600	<p>General features: Scale: degrees Celsius; internal setting</p> <p>Operating voltage: 230 VAC, 50 Hz or 24 VAC, 50 Hz</p> <p>Ambient temperature: 10 to 60 °C</p> <p>Protection class: II, if properly mounted; with 24 V, protection class III</p> <p>Max. switching current: heating (terminal 3) 230 VAC 10 (4) A or 24 VAC 2 (2) A, cooling (terminal 1) 5 (2) A or 24 VAC 2 (2) A</p> <p>Max. switching voltage: 230 VAC, 50 Hz</p> <p>Min. switching voltage: 24 VAC, 50 Hz</p> <p>Switching power: terminal 3: 2300 W at 230 VAC, 48 W at 24 VAC, terminal 1: 1150 W at 230 VAC, 48 W at 24 VAC</p> <p>Switching contact: changeover switch (toggler, max. 10 actuators output terminal 3, max. 5 actuators output terminal 1)</p> <p>Output signal: switching (230 VAC, 50 Hz or 24 VAC, 50 Hz)</p> <p>Control function: heating or cooling</p> <p>Control range: 10 to 60 °C</p> <p>Hysteresis: approx. 1.5 K at a temperature change of max. 4 K/h</p>		64.30/1

Accessories: terminal strips V00xx, suitable valve actuators ZBOOA



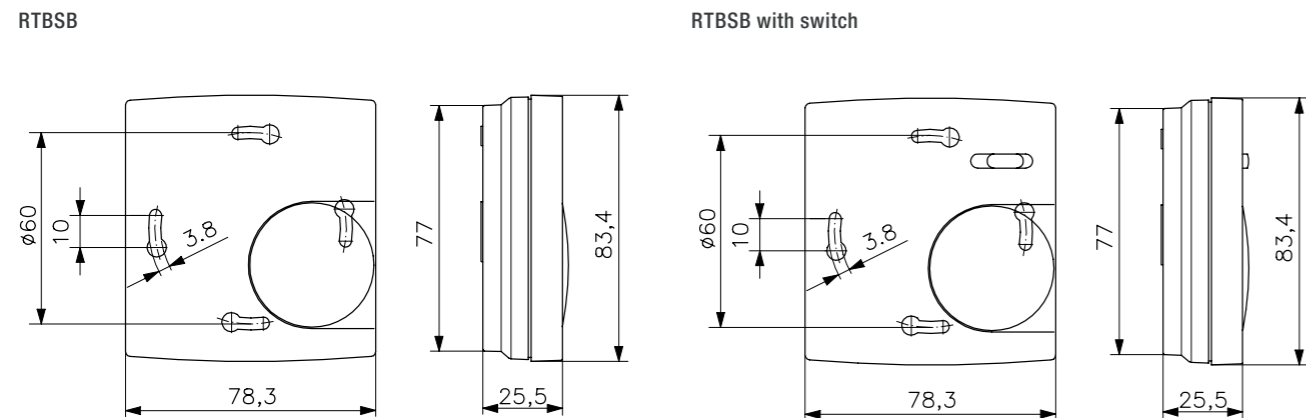

You can find other / similar controllers with outputs for heating / cooling and noiseless controllers in the Air Conditioning Technology chapter (note: applies to KTRTB, for example)

ILLUSTRATIONS



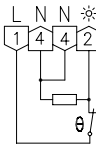



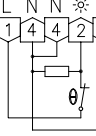

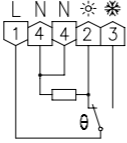

ACCESSORIES	ITEM NO.	FEATURES	EURO/PG
	MA990002	Adjusting knob for B2000 series devices, multi-digit display 1 to 6, pure white glossy	3.50/1

ROOM TEMPERATURE CONTROLLER, MECHANICAL, RTBSB SURFACE-MOUNTED 'ULTRA-THIN' INSTALLATION – DESIGN BERLIN 1000

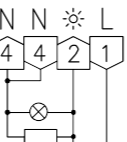
TYPE/IMAGE	ITEM NO.	FEATURES	CIRCUIT DIAGRAM	EURO/PG
	MA300000	<p>Design: Berlin 1000</p> <p>Surface finish: glossy</p> <p>Housing colour: pure white, similar to RAL 9010</p> <p>Housing material: ABS plastic</p> <p>Ambient temperature: 0 to 30 °C</p> <p>Storage temperature: -20 to +70 °C</p> <p>Permissible atmospheric humidity: Max. 95% rel. humidity, non-condensing</p> <p>Electrical connection: screw-type terminals 0.33 mm²–1.5 mm²</p> <p>Mounting / attachment: Surface / wall mounting (4-hole assembly on flush-mounted socket)</p> <p>Protection rating: IP30</p> <p>Safety and EMC: according to DIN EN 60730</p> <p>Average power consumption: < 0.25 W</p> <p>Max. switching current: 2 (1) A</p> <p>Switching element: bimetallic contact</p> <p>Sensor: bimetal</p> <p>Control range: 5 to 30 °C</p> <p>Hysteresis: approx. 0.5 K at a temperature change of max. 4 K/h</p> <p>General features: mechanical range limitation; thermal feedback; external setting</p>		43.60/1
	MA300008	Similar to RTBSB-201.000 but with multi-digit display 1–6		44.50/1
	MA300800	Similar to RTBSB-201.000 but with housing colour: traffic / studio white, similar to RAL 9016		43.60/1
	MA300100	<p>General features: ECO function; scale: degrees Celsius</p> <p>Operating voltage: 230 VAC, 50 Hz</p> <p>Protection class: II, if properly mounted</p> <p>Max. switching voltage: 230 VAC, 50 Hz</p> <p>Min. switching voltage: 230 VAC, 50 Hz</p> <p>Switching power: 460 W</p> <p>Switching contact: NC contact (max. 10 actuators)</p> <p>Output signal: switching (230 VAC, 50 Hz)</p> <p>Control function: heating</p> <p>Input 'temperature reduction': approx. 3 K (230 VAC, 50 Hz)</p>		46.20/1

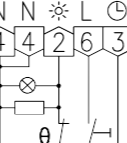
ROOM TEMPERATURE CONTROLLER, MECHANICAL, RTBSB

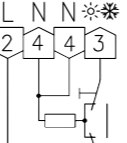
SURFACE-MOUNTED 'ULTRA-THIN' INSTALLATION – DESIGN BERLIN 1000

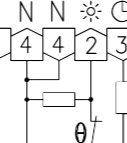
TYPE/IMAGE	ITEM NO.	FEATURES	CIRCUIT DIAGRAM	EURO/PG
	MA300200	General features: Scale: degrees Celsius Operating voltage: 230 VAC, 50 Hz Protection class: II, if properly mounted Max. switching voltage: 230 VAC, 50 Hz Min. switching voltage: 230 VAC, 50 Hz Switching power: 460 W Switching contact: changeover switch (toggler, max. 10 actuators (NC contact), max. 5 actuators (NO contact)) Output signal: switching (230 VAC, 50 Hz) Control function: Heating or cooling		54.30/1
	MA301400	General features: 'heating' display; scale: degrees Celsius Operating voltage: 230 VAC, 50 Hz Protection class: II, if properly mounted Max. switching voltage: 230 VAC, 50 Hz Min. switching voltage: 230 VAC, 50 Hz Switching power: 460 W Switching contact: NC contact (max. 10 actuators) Output signal: switching (230 VAC, 50 Hz) Control function: heating		47.80/1
	MA300400	General features: ECO function; 'heating' display; scale: degrees Celsius; 'on/off' switch Operating voltage: 230 VAC, 50 Hz Protection class: II, if properly mounted Max. switching voltage: 230 VAC, 50 Hz Min. switching voltage: 230 VAC, 50 Hz Switching power: 460 W Switching contact: NC contact (max. 10 actuators) Output signal: switching (230 VAC, 50 Hz) Control function: heating Input 'temperature reduction': approx. 3 K (230 VAC, 50 Hz)		57.10/1
	MA300500	General features: Climate controller for 2-pipe systems, especially heat pumps; scale: degrees Celsius; heating/cooling switch Operating voltage: 230 VAC, 50 Hz Protection class: II, if properly mounted Max. switching voltage: 230 VAC, 50 Hz Min. switching voltage: 230 VAC, 50 Hz Switching power: 460 W Switching contact: Changeover switch (toggler, max. 5 actuators) Output signal: switching (230 VAC, 50 Hz) Control function: heating or cooling		61.10/1
	MA300502	Similar to RTBSB-201.065 but with multi-digit display 1–6		62.00/1
	MA302100	General features: ECO function; scale: degrees Celsius Operating voltage: 24 VAC, 50 Hz Protection class: III Max. switching voltage: 24 VAC, 50 Hz Min. switching voltage: 24 VAC, 50 Hz Switching power: 48 W Switching contact: NC contact (max. 5 actuators) Output signal: switching (24 VAC, 50 Hz) Control function: heating Input 'temperature reduction': approx. 3 K (24 VAC, 50 Hz)		54.00/1

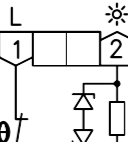

ROOM TEMPERATURE CONTROLLER, MECHANICAL, RTBSB

SURFACE-MOUNTED 'ULTRA-THIN' INSTALLATION – DESIGN BERLIN 1000

TYPE/IMAGE	ITEM NO.	FEATURES	CIRCUIT DIAGRAM	EURO/PG
	MA304000	General features: 2-wire room temperature controller; multi-digit display *–6 Operating voltage: 230 VAC, 50 Hz Ambient temperature: 0 to 30 °C Protection class: II, if properly mounted Max. switching current: 20 mA Min. switching current: 5 mA Max. switching voltage: 230 VAC, 50 Hz Min. switching voltage: 230 VAC, 50 Hz Switching power: 4.6 W (max. 2 actuators) Switching contact: NC contact Output signal: switching (230 VAC, 50 Hz) Control function: heating Control range: 5 to 30 °C Hysteresis: approx. 0.5 K at a temperature change of max. 4 K/h (load-dependent)		48.30/1

Accessories: terminal strips V00xx, suitable valve actuators ZB00A

You can find other / similar controllers with outputs for heating / cooling and noiseless controllers in the Air Conditioning Technology chapter (note: applies to KTRTB, for example)

ACCESSORIES	ITEM NO.	FEATURES	EURO/PG
	MN990006	Adapter frame for mounting room temperature controllers of the Berlin 1000 series in flush-mounted sockets up to 80 x 80 mm	5.60/1
	MA990000	Adjusting knob for B1000 series devices, scale: degrees Celsius, pure white glossy	3.70/1
	MA990001	Adjusting knob for B1000 series devices, multi-digit display 1 to 6, pure white glossy	3.70/1

ILLUSTRATIONS

RTBSB-201.xxx / KTRTB

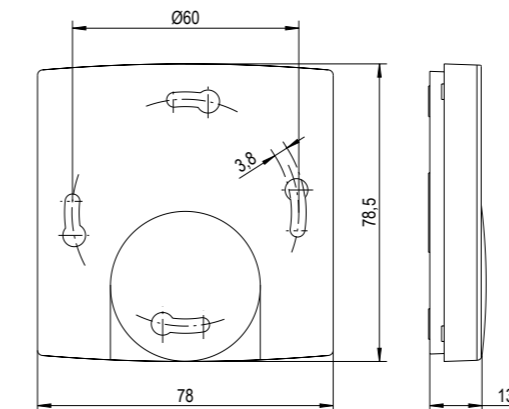

RTBSB-201.xxx with 'ON/OFF' switch at the side

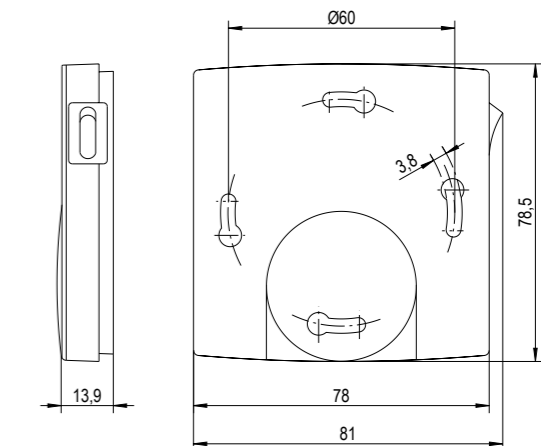

ROOM TEMPERATURE CONTROLLER, MECHANICAL, RTBSB SURFACE-MOUNTED OR PLUG-IN INSTALLATION – DESIGN BERLIN



TECHNICAL DATA

Design:	Berlin 2000
Surface finish:	matt
Housing colour:	pure white, similar to RAL 9010
Housing material:	ABS plastic
Operating voltage:	230 V AC, 50 Hz
Ambient temperature:	0 to 30 °C
Storage temperature:	-20 to +70 °C
Permissible atmospheric humidity:	Max. 95% rel. humidity, non-condensing
Protection rating:	IP30
Protection class:	II for loads of protection classes I and II
Safety and EMC:	according to DIN EN 60730
Max. switching voltage:	230 V AC, 50 Hz
Min. switching voltage:	230 V AC, 50 Hz
Switching element:	bimetallic contact
Switching contact:	NC contact
Output signal:	switching (230 VAC, 50 Hz)
Sensor:	bimetal
Control function:	heating
Control range:	5 to 30 °C
Hysteresis:	approx. 1 K at a temperature change of max. 4 K/h

APPLICATION

For controlling the room temperature for radiators, heating chimneys, direct electric heating systems, marble heating systems etc.

Attention! For loads > 2,300 W, the wall socket must be designed for 16 A (danger of fire).

The plugs are designed in such a way that they can also be used in sockets with a central pin (for example, as used in France).

TYPE/IMAGE	ITEM NO.	FEATURES	CIRCUIT DIAGRAM	EURO/PG
JZ-19	MN990003	General features: plug-in socket (as with RTBSB-001.411 / RTBSB-001.474) completely pre-wired Mounting/attachment: can be fitted with room thermostats RTBSB-001.xxx Protection rating: depends on the pre-fitted room thermostat Protection class: depends on the pre-fitted room thermostat Max. switching current: depends on the pre-fitted room thermostat Switching power: 3000 W		44.00/1
RTBSB-001.086	MA010800	General features: mechanical range setting; 3000 W switching power for electric direct heating systems, natural stone heating; thermal feedback; multi-digit display 1–6; external setting Electrical connection: screw-type terminals 0.12 mm ² –2.5 mm ² Average power consumption: < 0.5 W Max. switching current: 13 (4) A Switching power: 3000 W Accessories: can be combined with plug-in socket JZ-19		52.00/1
RTBSB-001.096	MA012500	Similar to RTBSB-001.086, but with 'heating' display (LED red)		52.00/1
RTBSB-001.401	MA013100	General features: mechanical range limitation; 3000 W switching power for electric direct heating systems, natural stone heating; multi-digit display 1–6; external setting Electrical connection: Schuko adapters Mounting/attachment: optionally surface / wall mounting (4-hole assembly on flush-mounted socket) or with adapter plate (2-hole assembly) for wall hanging Average power consumption: < 0.1 W Max. switching current: 13 (4) A Switching power: 3000 W Connecting cable: 1.5 m		69.50/1

ROOM TEMPERATURE CONTROLLER, MECHANICAL, RTBSB SURFACE-MOUNTED OR PLUG-IN INSTALLATION – DESIGN BERLIN

TYPE/IMAGE	ITEM NO.	FEATURES	CIRCUIT DIAGRAM	EURO/PG
RTBSB-001.411	MA013200	General features: mechanical range limitation; 3000 W switching power for electric direct heating systems, natural stone heating; multi-digit display 1–6; external setting Electrical connection: pre-fitted Schuko plug-in socket JZ-19 at the controller, 1.5-m cable with Schuko coupling Mounting/attachment: ready-to-plug Average power consumption: < 0.1 W Max. switching current: 13 (4) A Switching power: 3000 W Hysteresis: approx. 1 K at a temperature change of max. 4 K/h		90.00/1

ILLUSTRATIONS

Plug-in socket

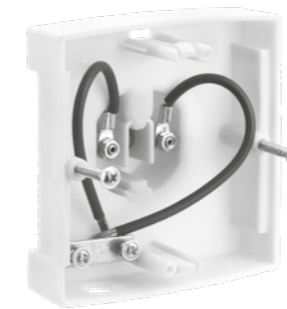

Plug-in socket

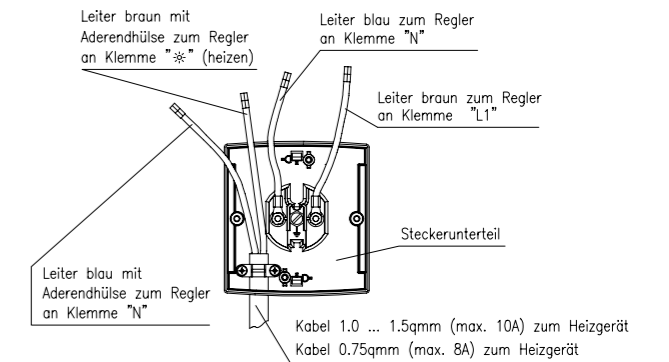

RTBSB-001.411



RTBSB-001.411 (Different from dimensions of RTBSB-001.401)

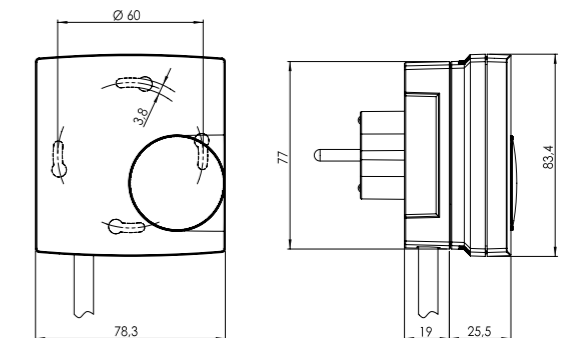

RTBSB-001.401



ROOM TEMPERATURE CONTROLLER WITH CLOCK, ELECTRONIC, HTRRBu SURFACE-MOUNTED INSTALLATION – DESIGN BERLIN 3000



TECHNICAL SPECIFICATIONS

Design:	Berlin 3000
Surface finish:	matt
Housing colour:	pure white, similar to RAL 9010
Housing material:	ABS plastic
Operating voltage:	230 V AC, 50 Hz
Ambient temperature:	0 to 30 °C
Storage temperature:	-20 to +70 °C
Permissible atmospheric humidity:	Max. 95% rel. humidity, non-condensing
Electrical connection:	screw-type terminals
Mounting/attachment:	surface / wall mounting or by means of an adapter plate on a flush-mounted socket
Protection rating:	IP30
Protection class:	II, if properly mounted
Safety and EMC:	according to DIN EN 60730
Max. switching current:	heating (terminal 4) 8 (2) A, cooling (terminal 3) 100 mA
Max. switching voltage:	230 V AC, 50 Hz
Min. switching voltage:	230 V AC, 50 Hz
Switching power:	terminal 4: 1840 W, terminal 3: 23 W
Switching element:	relay
Switching contact:	NO contact
Output signal:	heating, switching (230 VAC, 50 Hz)
Sensor:	NTC
Control function:	heating
Control range:	5 to 30 °C
Hysteresis:	< 1 K
Display type:	symbol display
Output 'temperature reduction':	switching (230 VAC, 50 Hz) (for pilot function)

APPLICATION

For time-dependent control of temperatures in closed spaces. Suitable for all heating systems.

Valve actuator: normally closed.

It can be used as a master (pilot regulator) for the temperature reduction of other controllers. Controllers of series FETR, RTBSU and RTBSB are suitable as slaves (satellite controllers).

Programming procedures for every day, familiar from mechanical timers, by means of 'electronic tabs'. Shortest switching time 15 min.

Load setting: The control accuracy is influenced by the different levels of intrinsic heating of the controller depending on the magnitude of the heating load. By inputting the heating load, this influence is compensated and the control accuracy is retained.

General features: pilot function; ECO function, ECO value adjustable; 'ECO' display; 'on/off' display; 'heating' display; digital actual value display; child-safe features; power reserve (approx. 4-7 days); load setting; actual value correction / measured value correction; learning function; valve protection; holiday setting; party setting; automatic adjustment to standard / daylight savings time; mechanical range limitation; scale: degrees Celsius; reduction / comfort / automatic button; external setting; operation using direct-dial buttons; on / off button; information button; party function button; holiday setting button

ROOM TEMPERATURE CONTROLLER WITH CLOCK, ELECTRONIC, HTRRBu SURFACE-MOUNTED INSTALLATION – DESIGN BERLIN 3000

ILLUSTRATIONS

HTRRBu 110.XXX

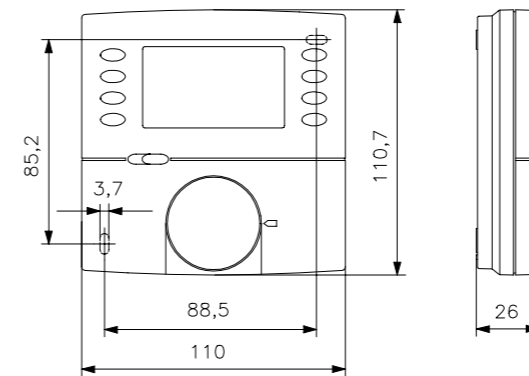

HTRRBu 110.XXX circuit diagram

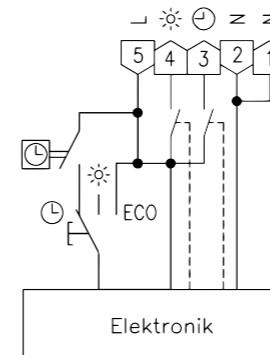

Factory setting:

- Setback temperature 17 °C
- Continuous time display
- Programme display using switching segments enabled
- Child-safe features disabled
- Automatic adjustment to summer / winter time enabled
- °C display, valve and pump protection disabled
- Learning function disabled
- Heating load 0.0 kW
- Comfort times:
Mon-Fri 5 am-9 am / 4 pm-10 pm,
Sat/Sun 6 am-10 pm

TYPE/IMAGE	ITEM NO.	FEATURES	EURO/PG
HTRRBu 110.117/21	MA600003		199.50/I



ACCESSORIES	ITEM NO.	FEATURES	EURO/PG
JZ-17	MN990001	Surface finish: matt Colour: pure white, similar to RAL 9010 Material: ABS plastic General features: adapter plate for mounting devices on flush-mounted sockets (including fastening screws for mounting the controller on the adapter plate)	8.20/II





ROOM TEMPERATURE CONTROLLER ELECTRONIC HTRRBd

SURFACE-MOUNTED `ULTRA-THIN` INSTALLATION – DESIGN BERLIN 1000

**TECHNICAL DATA**

Design:	Berlin 1000
Surface finish:	glossy
Housing colour:	pure white, similar to RAL 9010
Housing material:	ABS plastic
Ambient temperature:	0 to 40 °C
Storage temperature:	-20 to +70 °C
Permissible atmospheric humidity:	Max. 95% rel. humidity, non-condensing
Electrical connection:	screw-type terminals
Mounting / attachment:	Surface- / wall-mounting (4-hole assembly on flush-mounted socket)
Protection rating:	IP30
Protection class:	II, if properly mounted
Safety and EMC:	according to DIN EN 60730
Average power consumption:	< 0.5 W
Max. switching current:	3 (0.5) A
Switching element:	relay
Switching contact:	NO contact
Output signal:	switching, 230 VAC, 50 Hz
Sensor:	NTC, internal
Control range:	5 to 30 °C
Display:	2-digit 7-segment display (white)
Hysteresis:	< approx. 0.5 K at a temperature change of max. 4 K/h

APPLICATION

temperature control and monitoring in offices, homes and hotels, can be connected directly to the valve actuators for hot water heating systems.

Valve actuator: normally closed. Up to max. 10 actuators for valves can be connected.

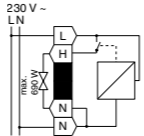
TYPE/IMAGE	ITEM NO.	CIRCUIT DIAGRAM	EURO/PG
HTRRBd-210.100 	MA700800		99.40 / I

ACCESSORIES	ITEM NO.	FEATURES	EURO/PG
JZ-21 	MN990006	Adapter frame for mounting the room temperature controller on flush-mounted sockets up to 80 x 80 mm	5.60 / I

ILLUSTRATIONS

Dimension schematic

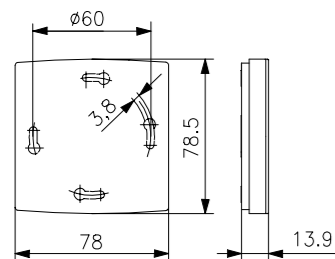

ROOM TEMPERATURE CONTROLLER, MECHANICAL, RTBSU

FLUSH-MOUNTED INSTALLATION – DESIGN BERLIN FLUSH-MOUNTED

**TECHNICAL DATA**

Design:	Berlin flush-mounted
Housing material:	PA6 plastic
Ambient temperature:	0 to 30 °C
Storage temperature:	-20 to +70 °C
Permissible atmospheric humidity:	Max. 95% rel. humidity, non-condensing
Electrical connection:	Spring-loaded terminals (lever actuation type)
Mounting / attachment:	In flush-mounted socket – with suitable cover set, can be adapted to fit virtually any switch range (deep flush-mounted socket recommended)
Protection rating:	IP30
Protection class:	II, if properly mounted, with 24 VAC, protection class III according to DIN EN 60730
Safety and EMC:	
Max. power consumption:	< 0.5 W
Switching element:	bimetallic contact
Output signal:	switching
Sensor:	bimetal
Control range:	5 to 30 °C
Setting range:	5 to 30 °C
Hysteresis:	approx. 0.5 K at a temperature change of max. 4 K/h
General features:	thermal recirculation; multi-digit display

APPLICATION



Control or monitoring of temperatures in closed, dry spaces. Suitable for all heating systems.

Valve actuator: normally closed. If normally open heating valves are available, they should be connected to the cooling output of the changeover switch (toggler), e.g., RTBSU-401.010



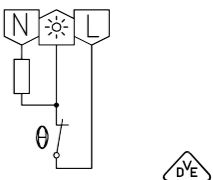

Up to a maximum of 10 actuators for valves can be connected (normally closed, NC); up to 5 units on the toggler with a NO contact.

In terms of visual aesthetics, the basic controllers (RTBSU-401.xxx#00), in combination with a 55 x 55 mm / 70 x 70 mm cover set, fit perfectly in many switch ranges without the use of an insert frame.



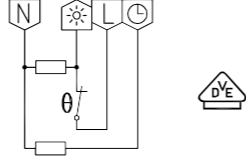

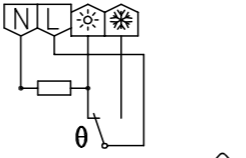

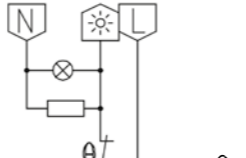
The basic controllers (RTBSU-401.xxx#00) in combination with a 50 x 50 mm cover set fit in nearly all switch ranges with the use of an insert frame.

TYPE/IMAGE	ITEM NO.	FEATURES	CIRCUIT DIAGRAM	EURO/PG
RTBSU-401.000#00 Comparison type: FTR 101.000#00 	UA090000	General features: mechanical range limitation; external setting; protective cap; VDE-tested Operating voltage: 230 VAC, 50 Hz Max. switching current: 10 (4) A Max. switching voltage: 230 VAC, 50 Hz Min. switching voltage: 230 VAC, 50 Hz Switching power: 2300 W Switching contact: NC contact (max. 10 actuators) Control function: heating		62.60 / I
RTBSU-401.000#21 Comparison type: FTR 101.000#21 	UA090014	Similar to RTBSU-401.000#00 but scope of delivery as follows: Controller, alre frame 'Berlin' (neutral), cover 50 x 50 mm, pure white (similar to RAL 9010), glossy		79.20 / I

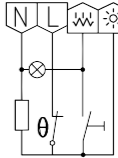
ROOM TEMPERATURE CONTROLLER, MECHANICAL, RTBSU FLUSH-MOUNTED INSTALLATION – DESIGN BERLIN FLUSH-MOUNTED

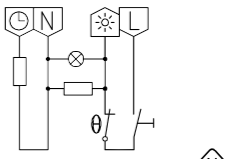
TYPE/IMAGE	ITEM NO.	FEATURES	CIRCUIT DIAGRAM	EURO/PG
RTBSU-401.002#00 Comparison type: FTR 101.002#00 	UA090001	General features: ECO function; mechanical range limitation; external setting; protective cap; VDE-tested Operating voltage: 230 VAC, 50 Hz Max. switching current: 10 (4) A Max. switching voltage: 230 VAC, 50 Hz Min. switching voltage: 230 VAC, 50 Hz Switching power: 2300 W Switching contact: NC contact (max. 10 actuators) Control function: heating Input 'temperature reduction': approx. 4 K (230 VAC, 50 Hz)		65.10 / I
Cover sets are offered in various designs (see the separate overview, 'alre flush-mounted range (cover sets)' and are not included in the delivery. Suitable set no.: JZ-001.xxx, (see page 79-81) e.g.: 50 x 50 mm cover set, pure white, glossy: JZ-001.000 55 x 55 mm cover set, pure white, glossy: JZ-001.100 BUSCH-JAEGER cover set Reflex SI/SI Linear, pure white, glossy: JZ-001.200/BJ				
RTBSU-401.010#00 Comparison type: FTR 101.010#00 	UA090002	General features: mechanical range limitation; external setting; protective cap; VDE-tested Operating voltage: 230 VAC, 50 Hz Max. switching current: heating terminal 10 (4) A, cooling terminal 5 (2) A Max. switching voltage: 230 VAC, 50 Hz Min. switching voltage: 230 VAC, 50 Hz Switching power: Heating terminal: 2300 W, Cooling terminal: 1150 W Switching contact: changeover switch (toggler, max. 10 actuators output heating, max. 5 actuators output cooling) Control function: heating or cooling		79.70 / I
Cover sets are offered in various designs (see the separate overview, 'alre flush-mounted range (cover sets)' and are not included in the delivery. Suitable set no.: JZ-001.xxx, (see page 79-81) e.g.: 50 x 50 mm cover set, pure white, glossy: JZ-001.000 55 x 55 mm cover set, pure white, glossy: JZ-001.100 BUSCH-JAEGER cover set Reflex SI/SI Linear, pure white, glossy: JZ-001.200/BJ				
RTBSU-401.034#00 Comparison type: FTR 101.034#07 / FTR 101.034#55 	UA090004	General features: 'heating' display; mechanical range limitation; external setting; protective cap, Operating voltage: 230 VAC, 50 Hz Max. switching current: 10 (4) A Max. switching voltage: 230 VAC, 50 Hz Min. switching voltage: 230 VAC, 50 Hz Switching power: 2300 W Switching contact: NC contact (max. 10 actuators) Control function: Heating		65.40 / I
Cover sets are offered in various designs (see the separate overview, 'alre flush-mounted range (cover sets)' and are not included in the delivery. Suitable set no.: JZ-016.xxx, (see page 79-81) e.g.: 50 x 50 mm cover set, pure white, glossy: JZ-016.000 55 x 55 mm cover set, pure white, glossy: JZ-016.100				

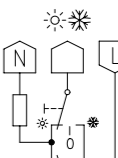

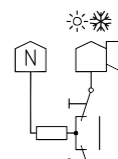

ROOM TEMPERATURE CONTROLLER, MECHANICAL, RTBSU FLUSH-MOUNTED INSTALLATION – DESIGN BERLIN FLUSH-MOUNTED

TYPE/IMAGE	ITEM NO.	FEATURES	CIRCUIT DIAGRAM	EURO/PG
RTBSU-401.052#21 Comparison type: FTR 101.052#21 	UA090015	General features: 'auxiliary heating' display; mechanical range limitation; auxiliary heating switch; external setting Operating voltage: 230 VAC, 50 Hz Max. switching current: the total current (heating + auxiliary heating) may not exceed 10 (4) A Max. switching voltage: 230 VAC, 50 Hz Min. switching voltage: 230 VAC, 50 Hz Switching power: the total power output (heating + auxiliary heating) may not exceed 2300 W Switching contact: NC contact (max. 10 actuators) Control function: heating Scope of delivery: Controller, alre frame 'Berlin' (neutral), 50 x 50 mm cover, pure white (similar to RAL 9010), glossy		97.50 / I
RTBSU-401.062#00 Comparison type: FTR 101.062#00 	UA090003	General features: ECO function; 'heating' display; mechanical range limitation; 'on/off' switch; external setting; protective cap; VDE-tested Operating voltage: 230 VAC, 50 Hz Max. switching current: 10 (4) A Max. switching voltage: 230 VAC, 50 Hz Min. switching voltage: 230 VAC, 50 Hz Switching power: 2300 W Switching contact: NC contact (max. 10 actuators) Control function: heating Input 'temperature reduction': approx. 4 K (230 VAC, 50 Hz)		81.10 / I
Cover sets are offered in various designs (see the separate overview, 'alre flush-mounted range (cover sets)' and are not included in the delivery. Suitable set no.: JZ-035.xxx, (see page 79-81) e.g.: 50 x 50 mm cover set, pure white, glossy: JZ-035.000 55 x 55 mm cover set, pure white, glossy: JZ-035.100 BUSCH-JAEGER cover set Reflex SI/SI Linear, pure white, glossy: JZ-035.200/BJ				
RTBSU-401.063#00 Comparison type: FTR 101.063#00 	UA090006	General features: climate controller for 2-pipe systems, mechanical range limitation; 'heating/off/cooling' switch; external adjustment; protective cap Operating voltage: 230 V AC, 50 Hz Max. switching current: 5 (2) A Max. switching voltage: 230 V AC, 50 Hz Min. switching voltage: 230 V AC, 50 Hz Switching power: 1150 W Switching contact: changeover switch (max. 5 actuators) Control function: heating or cooling		88.70 / I
For cover sets see the separate overview 'alre flush-mounted range (cover sets)', not included in the delivery. Suitable set no.: JZ-038.xxx, (see page 79-81) e.g.: 50 x 50 mm cover set, pure white, glossy: JZ-038.000 55 x 55 mm cover set, pure white, glossy: JZ-038.100				
RTBSU-401.065#00 Comparison type: FTR 101.065#00 	UA090007	General features: climate controller for 2-pipe systems, especially heat pumps; mechanical range limitation; 'heating/cooling' switch; external setting; protective cap Operating voltage: 230 VAC, 50 Hz Max. switching current: 5 (2) A Max. switching voltage: 230 VAC, 50 Hz Min. switching voltage: 230 VAC, 50 Hz Switching power: 1150 W Switching contact: changeover switch (toggler, max. 5 actuators) Control function: heating or cooling		87.60 / I
Cover sets are offered in various designs (see the separate overview, 'alre flush-mounted range (cover sets)' and are not included in the delivery. Suitable set no.: JZ-037.xxx, (see page 79-81) e.g.: 50 x 50 mm cover set, pure white, glossy: JZ-037.000 55 x 55 mm cover set, pure white, glossy: JZ-037.100				

ROOM TEMPERATURE CONTROLLER, MECHANICAL, RTBSU FLUSH-MOUNTED INSTALLATION – DESIGN BERLIN FLUSH-MOUNTED

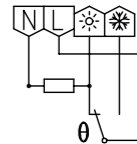
TYPE/IMAGE	ITEM NO.	FEATURES	CIRCUIT DIAGRAM	EURO/PG
 <p>RTBSU-401.075#00 Comparison type: FTR 101.075#00</p>	UA090008	<p>General features: ECO function; 'reduction' display; mechanical range limitation; switch for reduction / heating / reduction via external timer' switch; external setting; protective cap; VDE-tested</p> <p>Operating voltage: 230 VAC, 50 Hz Max. switching current: 10 (4) A Max. switching voltage: 230 VAC, 50 Hz Min. switching voltage: 230 VAC, 50 Hz Switching power: 2300 W Switching contact: NC contact (max. 10 actuators) Control function: heating Input 'temperature reduction': approx. 4 K (230 VAC, 50 Hz)</p> <p>Cover sets are offered in various designs (see the separate overview, 'alre flush-mounted range (cover sets)') and are not included in the delivery. Suitable set no.: JZ-036.xxx, (see page 79-81) e.g.: 50 x 50 mm cover set, pure white, glossy: JZ-036.000 55 x 55 mm cover set, pure white, glossy: JZ-036.100</p>		85.20 / I
 <p>RTBSU-401.086#00 Comparison type: FTR 101.086#00</p>	UA090009	<p>General features: mechanical range limitation; 3000 W switching power, for electric direct heating systems, natural stone heating; external setting; protective cap</p> <p>Operating voltage: 230 VAC, 50 Hz Max. switching current: 13 (4) A Max. switching voltage: 230 VAC, 50 Hz Min. switching voltage: 230 VAC, 50 Hz Switching power: 3000 W Switching contact: NC contact Control function: heating</p> <p>Cover sets are offered in various designs (see the separate overview, 'alre flush-mounted range (cover sets)') and are not included in the delivery. Suitable set no.: JZ-001.xxx, (see page 79-81) e.g.: 50 x 50 mm cover set, pure white, glossy: JZ-001.000 55 x 55 mm cover set, pure white, glossy: JZ-001.100 BUSCH-JAEGER cover set Reflex SI / SI Linear, pure white, glossy: JZ-001.200 / BJ</p>		69.30 / I
 <p>RTBSU-401.086#21 Comparison type: FTR 101.086#21</p>	UA090016	<p>Similar to RTBSU-401.086#00 but scope of delivery as follows: Controller, alre frame 'Berlin' (neutral), cover 50 x 50 mm, pure white (like RAL 9010), glossy</p>		85.80 / I
 <p>RTBSU-401.202#00 Comparison type: FTR 101.202#00</p>	UA090010	<p>General features: ECO function; mechanical range limitation; external setting; protective cap</p> <p>Operating voltage: 24 VAC / 50 Hz, 24 VDC Max. switching current: 1 (1) A Max. switching voltage: 24 VAC / 50 Hz, 24 VDC Min. switching voltage: 24 VAC / 50 Hz, 24 VDC Switching power: 24 W Switching contact: NC contact (max. 5 actuators) Control function: heating Input 'temperature reduction': approx. 4 K (24 VAC / 50 Hz, 24 VDC)</p> <p>Cover sets are offered in various designs (see the separate overview, 'alre flush-mounted range (cover sets)') and are not included in the delivery. Suitable set no.: JZ-001.xxx, (see page 79-81) e.g.: 50 x 50 mm cover set, pure white, glossy: JZ-001.000 55 x 55 mm cover set, pure white, glossy: JZ-001.100 BUSCH-JAEGER cover set Reflex SI / SI Linear, pure white, glossy: JZ-001.200 / BJ</p>		76.60 / I

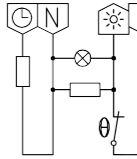
ROOM TEMPERATURE CONTROLLER, MECHANICAL, RTBSU FLUSH-MOUNTED INSTALLATION – DESIGN BERLIN FLUSH-MOUNTED

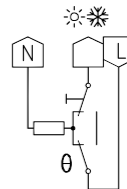

TYPE/IMAGE	ITEM NO.	FEATURES	CIRCUIT DIAGRAM	EURO/PG
 <p>RTBSU-401.210#00 Comparison type: FTR 101.210#00</p>	UA090011	<p>General features: mechanical range limitation; external setting; protective cap</p> <p>Operating voltage: 24 VAC / 50 Hz, 24 VDC Max. switching current: 1 (1) A Max. switching voltage: 24 VAC / 50 Hz, 24 VDC Min. switching voltage: 24 VAC / 50 Hz, 24 VDC Switching power: 24 W Switching contact: changeover switch (toggler, max. 5 actuators) Control function: heating or cooling</p> <p>Cover sets are offered in various designs (see the separate overview, 'alre flush-mounted range (cover sets)') and are not included in the delivery. Suitable set no.: JZ-001.xxx, (see page 79-81) e.g.: 50 x 50 mm cover set, pure white, glossy: JZ-001.000 55 x 55 mm cover set, pure white, glossy: JZ-001.100 BUSCH-JAEGER cover set Reflex SI / SI Linear, pure white, glossy: JZ-001.200 / BJ</p>		87.90 / I
 <p>RTBSU-401.262#00 Comparison type: FTR 101.262#00</p>	UA090012	<p>General features: ECO function; 'heating' display; mechanical range limitation; 'on/off' switch; external setting; protective cap</p> <p>Operating voltage: 24 VAC / 50 Hz Max. switching current: 1 (1) A Max. switching voltage: 24 VAC / 50 Hz Min. switching voltage: 24 VAC / 50 Hz Switching power: 24 W Switching contact: NC contact (max. 5 actuators) Control function: heating Input 'temperature reduction': approx. 4 K (24 VAC / 50 Hz)</p> <p>Cover sets are offered in various designs (see the separate overview, 'alre flush-mounted range (cover sets)') and are not included in the delivery. Suitable set no.: JZ-035.xxx, (see page 79-81) e.g.: 50 x 50 mm cover set, pure white, glossy: JZ-035.000 55 x 55 mm cover set, pure white, glossy: JZ-035.100 BUSCH-JAEGER cover set Reflex SI / SI Linear, pure white, glossy: JZ-035.200 / BJ</p>		89.10 / I
 <p>RTBSU-401.265#00 Comparison type: FTR 101.265#00</p>	UA090017	<p>General features: climate controller for 2-pipe systems, especially heat pumps; mechanical range limitation; 'heating / cooling' switch; external setting; protective cap</p> <p>Operating voltage: 24 VAC / 50 Hz, 24 VDC Max. switching current: 1 (1) A Max. switching voltage: 24 VAC / 50 Hz, 24 VDC Min. switching voltage: 24 VAC / 50 Hz, 24 VDC Switching power: 24 W Switching contact: changeover switch (toggler, max. 5 actuators) Control function: heating or cooling</p> <p>Cover sets are offered in various designs (see the separate overview, 'alre flush-mounted range (cover sets)') and are not included in the delivery. Suitable set no.: JZ-037.xxx, (see page 79-81) e.g.: 50 x 50 mm cover set, pure white, glossy: JZ-037.000 55 x 55 mm cover set, pure white, glossy: JZ-037.100</p>		96.20 / I

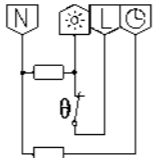
ROOM TEMPERATURE CONTROLLER, MECHANICAL, RTBSU FLUSH-MOUNTED INSTALLATION – DESIGN BERLIN FLUSH-MOUNTED

TYPE/IMAGE	ITEM NO.	FEATURES	CIRCUIT DIAGRAM	EURO/PG
	UA090013	General features: ECO function; internal setting Operating voltage: 230 VAC, 50 Hz Max. switching current: 10 (4) A Max. switching voltage: 230 VAC, 50 Hz Min. switching voltage: 230 VAC, 50 Hz Switching power: 2300 W Switching contact: NC contact (max. 10 actuators) Control function: heating Input 'temperature reduction': approx. 4 K (230 VAC, 50 Hz) Scope of delivery: Controller, 50 x 50 mm cover, pure white (similar to RAL 9010), glossy		82.70/I

For model RTBSU-401.xxx#21, the protective cap is not included in the delivery.

Accessories terminal strips VOOxx, suitable valve actuators ZBOOA, suitable cover sets: see separate overview 'alre flush-mounting range (cover sets)'

TYPE/IMAGE	ITEM NO.	FEATURES	EURO/PG
	VV000025	General features: spare part for RTBSU-401.902#07 flush-mounted installation with 50 x 50 mm cover Design: Berlin Surface finish: glossy Colour: Pure white, similar to RAL 9010 Material: PC plastic	9.00/I
	VV000025	General features: alre frame 'Berlin' (neutral) for all flush-mounted controllers with 50 x 50 mm cover Design: Berlin Surface finish: glossy Colour: Pure white, similar to RAL 9010 Material: PC plastic	4.80/I
JZ-090.100	VV000048	Similar to JZ-090.900, but for all flush-mounted controllers in combination with 55 x 55 mm cover	4.80/I
JZ-090.910	VV000010	as for JZ-090.900, but colour similar to RAL 1013	4.80/I

ILLUSTRATIONS

alre frame 'Berlin' (#21 types)

with 50 x 50 insert frame

without 55 x 55 insert frame

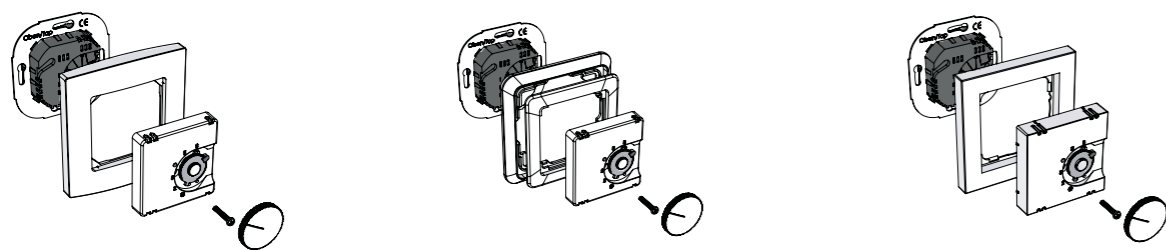

ILLUSTRATIONS

RTBSU with alre frame 'Berlin' (RTBSU-401.xxx#21 types)

RTBSU scale for temperature adjustment without cover set

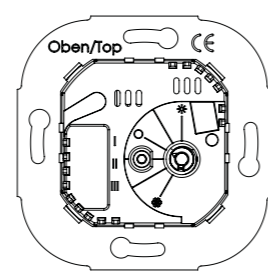
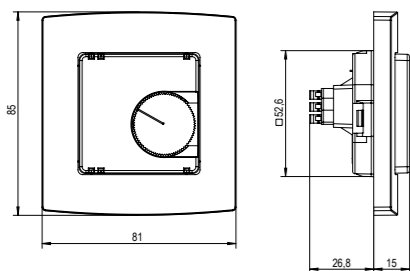

ALRE FLUSH-MOUNTED RANGE (50 X 50 MM COVER SETS)

ALL BASIC TYPES AND SUITABLE COVER SETS **50 X 50 MM**

BASIC TYPE	50 x 50 mm cover set PURE WHITE (RAL 9010) GLOSSY		50 x 50 mm cover set PURE WHITE (RAL 9010) MATT		50 x 50 mm cover set PEARL WHITE (RAL1013) GLOSSY		EUROS/ PG
	Cover set	Item no.	Cover set	Item no.	Cover set	Item no.	
RTBSU-401.000#00	JZ-001.000	UN990035	JZ-001.001	UN990040	JZ-001.010	UN990045	9.00/I
RTBSU-401.002#00	JZ-001.000	UN990035	JZ-001.001	UN990040	JZ-001.010	UN990045	9.00/I
RTBSU-401.010#00	JZ-001.000	UN990035	JZ-001.001	UN990040	JZ-001.010	UN990045	9.00/I
RTBSU-401.034#00	JZ-016.000	UN990139	-	-	-	-	9.20/I
RTBSU-401.062#00	JZ-035.000	UN990169	JZ-035.001	UN990193	JZ-035.010	UN990177	9.50/I
RTBSU-401.063#00	JZ-038.000	UN990170	JZ-038.001	UN990194	JZ-038.010	UN990178	9.20/I
RTBSU-401.065#00	JZ-037.000	UN990171	JZ-037.001	UN990195	JZ-037.010	UN990179	9.20/I
RTBSU-401.075#00	JZ-036.000	UN990172	JZ-036.001	UN990196	JZ-036.010	UN990180	9.50/I
RTBSU-401.086#00	JZ-001.000	UN990035	JZ-001.001	UN990040	JZ-001.010	UN990045	9.00/I
RTBSU-401.202#00	JZ-001.000	UN990035	JZ-001.001	UN990040	JZ-001.010	UN990045	9.00/I
RTBSU-401.210#00	JZ-001.000	UN990035	JZ-001.001	UN990040	JZ-001.010	UN990045	9.00/I
RTBSU-401.262#00	JZ-035.000	UN990169	JZ-035.001	UN990193	JZ-035.010	UN990177	9.50/I
RTBSU-401.265#00	JZ-037.000	UN990171	JZ-037.001	UN990195	JZ-037.010	UN990179	9.20/I

In flush-mounted socket, it can be adapted to fit virtually any switch range.

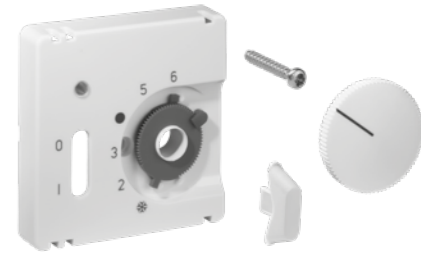
BASIC TYPE	50 x 50 mm cover set TRAFFIC/STUDIO WHITE (RAL 9016) GLOSSY (JZ-xxx.020)		50 x 50 mm cover set TRAFFIC/STUDIO WHITE (RAL 9016) MATT (JZ-xxx.021)		EURO / PG	Cover set (example), individually foil-wrapped
	Cover set	Item no.	Cover set	Item no.		
RTBSU-401.000#00	JZ-001.020	UN990071	JZ-001.021	UN990100	9.00/I	
RTBSU-401.002#00	JZ-001.020	UN990071	JZ-001.021	UN990100	9.00/I	
RTBSU-401.010#00	JZ-001.020	UN990071	JZ-001.021	UN990100	9.00/I	
RTBSU-401.062#00	JZ-035.020	UN990185	JZ-035.021	UN990201	9.50/I	
RTBSU-401.063#00	JZ-038.020	UN990186	JZ-038.021	UN990202	9.20/I	
RTBSU-401.065#00	JZ-037.020	UN990187	JZ-037.021	UN990203	9.20/I	
RTBSU-401.075#00	JZ-036.020	UN990188	JZ-036.021	UN990204	9.50/I	
RTBSU-401.086#00	JZ-001.020	UN990071	JZ-001.021	UN990100	9.00/I	
RTBSU-401.202#00	JZ-001.020	UN990071	JZ-001.021	UN990100	9.00/I	
RTBSU-401.210#00	JZ-001.020	UN990071	JZ-001.021	UN990100	9.00/I	
RTBSU-401.262#00	JZ-035.020	UN990185	JZ-035.021	UN990201	9.50/I	
RTBSU-401.265#00	JZ-037.020	UN990187	JZ-037.021	UN990203	9.20/I	

SEE THE PRODUCT FINDER ON PAGE 83-89 FOR ALL COVER SOLUTIONS AND SPECIAL COLOURS

ALRE FLUSH-MOUNTED RANGE (55 X 55 MM COVER SETS)

ALL BASIC TYPES AND SUITABLE COVER SETS **55 X 55 MM**

BASIC TYPE	55 x 55 mm cover set PURE WHITE (RAL 9010) GLOSSY (JZ-xxx.100)		55 x 55 mm cover set PURE WHITE (RAL 9010) MATT (JZ-xxx.101)		55 x 55 mm cover set PEARL WHITE (RAL1013) GLOSSY(-JZ-xxx.110)		EU-ROS/PG 55 x 55 mm cover set TRAFFIC/STUDIO WHITE (RAL 9016) GLOSSY (JZ-xxx.120)		EU-ROS/PG	
	Cover set	Item no.	Cover set	Item no.	Cover set	Item no.	Cover set	Item no.		
RTBSU-401.000#00	JZ-001.100	UN990050	JZ-001.101	UN990055	JZ-001.110	UN990060	9.00/I	JZ-001.120	UN990086	9.50/I
RTBSU-401.002#00	JZ-001.100	UN990050	JZ-001.101	UN990055	JZ-001.110	UN990060	9.00/I	JZ-001.120	UN990086	9.50/I
RTBSU-401.010#00	JZ-001.100	UN990050	JZ-001.101	UN990055	JZ-001.110	UN990060	9.00/I	JZ-001.120	UN990086	9.50/I
RTBSU-401.034#00	JZ-016.100	UN990140	-	-	-	-	16.80/I	-	-	
RTBSU-401.062#00	JZ-035.100	UN990173	JZ-035.101	UN990197	JZ-035.110	UN990181	10.00/I	JZ-035.120	UN990189	10.00/I
RTBSU-401.063#00	JZ-038.100	UN990174	JZ-038.101	UN990198	JZ-038.110	UN990182	9.70/I	JZ-038.120	UN990190	9.70/I
RTBSU-401.065#00	JZ-037.100	UN990175	JZ-037.101	UN990199	JZ-037.110	UN990183	9.70/I	JZ-037.120	UN990191	9.70/I
RTBSU-401.075#00	JZ-036.100	UN990176	JZ-036.101	UN990200	JZ-036.110	UN990184	10.00/I	JZ-036.120	UN990192	10.00/I
RTBSU-401.086#00	JZ-001.100	UN990050	JZ-001.101	UN990055	JZ-001.110	UN990060	9.00/I	JZ-001.120	UN990086	9.50/I
RTBSU-401.202#00	JZ-001.100	UN990050	JZ-001.101	UN990055	JZ-001.110	UN990060	9.00/I	JZ-001.120	UN990086	9.50/I
RTBSU-401.210#00	JZ-001.100	UN990050	JZ-001.101	UN990055	JZ-001.110	UN990060	9.00/I	JZ-001.120	UN990086	9.50/I
RTBSU-401.262#00	JZ-035.100	UN990173	JZ-035.101	UN990197	JZ-035.110	UN990181	10.00/I	JZ-035.120	UN990189	10.00/I
RTBSU-401.265#00	JZ-037.100	UN990175	JZ-037.101	UN990199	JZ-037.110	UN990183	9.70/I	JZ-037.120	UN990191	9.70/I

Can be adapted to fit many switch ranges in flush-mounted sockets (for a current overview of the suitable frames and insert frames, see page 82).

ALRE FLUSH-MOUNTED RANGE (70 X 70 MM COVER SETS)

ALL BASIC TYPES AND SUITABLE COVER SETS **70 X 70 MM**

BASIC TYPE	70 x 70 mm cover set PURE WHITE (RAL 9010) GLOSSY (JZ-xxx.400)		70 x 70 mm cover set PEARL WHITE (RAL1013) GLOSSY(JZ-xxx.410)		EU-ROS/PG	70 x 70 mm cover set TRAFFIC/STUDIO WHITE (RAL 9016) GLOSSY (JZ-xxx.420)		EUROS/PG
	Cover set	Item no.	Cover set	Item no.		Cover set	Item no.	
RTBSU-401.000#00	JZ-001.400	UN990141	JZ-001.410	UN990145	9.50/I	JZ-001.420	UN990149	9.50/I
RTBSU-401.002#00	JZ-001.400	UN990141	JZ-001.410	UN990145	9.50/I	JZ-001.420	UN990149	9.50/I
RTBSU-401.010#00	JZ-001.400	UN990141	JZ-001.410	UN990145	9.50/I	JZ-001.420	UN990149	9.50/I
RTBSU-401.034#00	JZ-016.400	UN990142	JZ-016.410	UN990146	9.70/I	JZ-016.420	UN990150	9.70/I
RTBSU-401.062#00	JZ-035.400	UN990143	JZ-035.410	UN990147	10.00/I	JZ-035.420	UN990151	10.00/I
RTBSU-401.065#00	JZ-037.400	UN990144	JZ-037.410	UN990148	9.70/I	JZ-037.420	UN990150	9.70/I
RTBSU-401.086#00	JZ-001.400	UN990141	JZ-001.410	UN990145	9.50/I	JZ-001.420	UN990149	9.50/I
RTBSU-401.202#00	JZ-001.400	UN990141	JZ-001.410	UN990145	9.50/I	JZ-001.420	UN990149	9.50/I
RTBSU-401.210#00	JZ-001.400	UN990141	JZ-001.410	UN990145	9.50/I	JZ-001.420	UN990149	9.50/I
RTBSU-401.262#00	JZ-035.400	UN990143	JZ-035.410	UN990147	10.00/I	JZ-035.420	UN990151	10.00/I
RTBSU-401.265#00	JZ-037.400	UN990144	JZ-037.410	UN990148	9.70/I	JZ-037.420	UN990150	9.70/I

Can be adapted to fit many switch ranges in flush-mounted sockets (for a current overview of the suitable frames and insert frames, see page 82).

ALL BASIC TYPES AND SUITABLE COVER SETS FOR **BUSCH-JAEGER REFLEX SI/SI LINEAR / BUSCH-DURO 2000 SI / FUTURE / SOLO / AXCENT / CARAT** WITHOUT INSERT FRAME

BASIC TYPE	BUSCH-JAEGER cover set REFLEX SI/SI LINEAR PURE WHITE (RAL 9010) GLOSSY (JZ-xxx.200/BJ)		BUSCH-JAEGER cover set BUSCH-DURO 2000 SI/SI LINEAR PEARL WHITE (RAL 1013) GLOSSY (JZ-001.210/BJ)		EURO/PG	BUSCH-JAEGER cover set FUTURE LINEAR/SOLO/ AXCENT / CARAT TRAF- FIC/STUDIO WHITE (RAL 9016) GLOSSY (JZ-001.320/BJ)		EURO/PG
	Cover set	Item no.	Cover set	Item no.		Cover set	Item no.	
RTBSU-401.000#00	JZ-001.200/BJ	G9990490	JZ-001.210/BJ	G9990491	9.50/I	JZ-001.320/BJ	G9990493	9.50/I
RTBSU-401.002#00	JZ-001.200/BJ	G9990490	JZ-001.210/BJ	G9990491	9.50/I	JZ-001.320/BJ	G9990493	9.50/I
RTBSU-401.010#00	JZ-001.200/BJ	G9990490	JZ-001.210/BJ	G9990491	9.50/I	JZ-001.320/BJ	G9990493	9.50/I
RTBSU-401.062#00	JZ-035.200/BJ	G9990499	-	-	10.00/I	-	-	
RTBSU-401.086#00	JZ-001.200/BJ	G9990490	JZ-001.210/BJ	G9990491	9.50/I	JZ-001.320/BJ	G9990493	9.50/I
RTBSU-401.202#00	JZ-001.200/BJ	G9990490	JZ-001.210/BJ	G9990491	9.50/I	JZ-001.320/BJ	G9990493	9.50/I

Can be adapted to fit the corresponding BUSCH-JAEGER switch ranges in flush-mounted sockets.

SPECIAL COLOURS ANTHRACITE

ALRE CON- TROLLER TYPES	MANUFACTURER SWITCH RANGE	COLOUR/ SURFACE FINISH	50 X 50 MM INSERT FRAME*	ALRE COVER SET: TYPE	(ITEM NO.)	EURO/ PG
RTBSU-401.000#00 RTBSU-401.002#00 RTBSU-401.010#00 RTBSU-401.086#00 RTBSU-401.202#00 RTBSU-401.210#00	GIRA System 55	anthracite / matt	not required	JZ-001.141 / GI	(UN990111)	20.30/I

*) must be ordered from switch manufacturer or electronics wholesaler
Further details and information on available cover sets can be found online at www.alre.de or in the catalogue.



ADAPTATION OF ALRE FLUSH-MOUNTED CONTROLLERS

MANUFACTURER	RANGE	COLOUR RAL 9010 (surface finish)	ADAPTATION possible using '55 x 55', '70 x 70' or 'BJ' cover sets (without insert frame)	Only ADAPTATION with '50 x 50' cover set requires an insert frame from the manufacturer
BERKER	S.1	polar white (matt)	x	1109 19 19
BERKER	S.1	polar white (glossy)	x	1109 90 89
BERKER	Arsys	polar white (glossy)		1108 01 69
BERKER	B.3	aluminium / polar white (matt)	x	1109 19 19
BERKER	B.3	aluminium / polar white (glossy)	x	1109 90 89
BERKER	B.7	glass / polar white (matt)	x	1109 19 19
BERKER	B.7	glass / polar white (glossy)	x	1109 90 89
BERKER	Q.1 / Q.3	polar white (velvet)		1109 60 79
BERKER	K.1	polar white (glossy)		1108 71 09
BUSCH-JAEGER	Reflex SI / SI Linear	alpine white (glossy)	x	1746-214-101
BUSCH-JAEGER	Busch-balance SI	alpine white (glossy)	x	1746-914-101
BUSCH-JAEGER	impuls	alpine white (glossy)		1746 / 10-74
BUSCH-JAEGER	solo / future linear / axcent / etc.	studio white – see RAL 9016 below		
Elso	Joy	pure white (glossy)	x	363084
Elso	Fashion / Riva / Scala	pure white (glossy)		203084
GIRA	surface switch	pure white (glossy)	x	0282 112
GIRA (System 55)	Standard / E2	pure white (semi-gloss)	x	0282 27
GIRA (System 55)	Standard / E2 / E3	pure white (glossy)	x	0282 03
GIRA (System 55)	E22	pure white (glossy)	x	0282 03
GIRA (System 55)	Event	pure white (semi-gloss) + opaque...	x	0282 27
GIRA (System 55)	Event	pure white (glossy) + opaque...	x	0282 03
GIRA (System 55)	Esprit	pure white (semi-gloss) + glass, aluminium...	x	0282 27
GIRA (System 55)	Esprit	pure white (glossy) + glass, aluminium...	x	0282 03
GIRA	S-Color	pure white (high-gloss)		0282 40
JUNG	CD 500 / CD plus	alpine white (glossy)		CD 590 Z WW
JUNG	A 500 / A 550 / AS 500 / A plus / A flow	alpine white (glossy)	x	A 590 Z WW
JUNG	LS 990	alpine white (glossy)	x	LS 961 Z WW
JUNG	LS plus	alpine white (glass)	x	LS 961 Z WW
JUNG	A creation	alpine white (glossy)	x	A 590 Z WW
JUNG	LS Design	alpine white (glossy)	x	LS 961 Z WW
MERTEN (System M)	M-Smart, M-Plan, M-Pure	polar white (matt)	x	5181 19
MERTEN (System M)	M-Smart, M-Plan, M-Creativ, M-Pure	polar white (glossy)	x	5185 19
MERTEN (System Basis)	1-M / Atelier-M	polar white (glossy)	x	5185 19
MERTEN (Surface System)	Artec / Antik	polar white (glossy)		5160 99
MERTEN	1-M / M-Smart / M-Plan / M-Pure / D-Life	active white – see RAL 9016 below or product finder		
PEHA	Standard	pure white (glossy)		80.670.02 ZV
PEHA	Dialog	pure white (glossy)		95.670.02 ZV
PEHA	Aura	pure white (matt) / glass		20.670.02 ZV
PEHA	Badora	pure white (glossy)		11.670.02 ZV

MANUFACTURER	RANGE	COLOUR RAL 9016 (surface finish)	ADAPTATION possible using '55 x 55', '70 x 70' or 'BJ' cover sets (without insert frame)	Only ADAPTATION with '50 x 50' cover set requires an insert frame from the manufacturer
BUSCH-JAEGER	solo / future linear	studio white (RAL 9016, glossy)	x	1746 / 10-84
BUSCH-JAEGER	future linear	studio white (RAL 9016 matt)		1746 / 10-884
BUSCH-JAEGER	impuls	studio white (RAL 9016 matt)		1746 / 10-774
BUSCH-JAEGER	axcent	studio white (RAL 9016, glossy)	x	1746 / 10-84
BUSCH-JAEGER	carat (glass, bronze, gold)	studio white (RAL 9016, glossy)	x	1746 / 10-84
BUSCH-JAEGER	alpha (nea / exclusive *)	studio white (RAL 9016, glossy)		1746 / 10-24G
BUSCH-JAEGER	alpha (nea / exclusive *)	studio white (RAL 9016 matt)		1746 / 10-24
MERTEN	M-Smart, M-Plan, M-Pure	active white (RAL 9016, glossy)	x	5185 25
MERTEN	1-M / Atelier-M	active white (RAL 9016, glossy)	x	5185 25
MERTEN	D-Life	lotus white (RAL 9016)	x	MEG4500-6035
PEHA	Standard	arctic		D 80.670 ZV AW

*) During assembly, you need to remove 4 plastic tabs located at the rear of the frame

NOTE: Most switch ranges are designed in a colour similar to RAL 1013, 9016 or 1013, although different switch manufacturers use different designations for this colour. Coloured, glass and aluminium frames are also combined with white jacks or plugs so that controllers with white covers can also be integrated into these frames. Check the precise application in each individual case. The frames have different surface qualities (matt / glossy). For design reasons, the cover of the controller should have the same quality as the frame. We accept no liability for slight variations in colour and surface finish or for accuracy of fit. When installing devices into multi frames, always assemble the temperature controllers at the lowermost position.

'50 x 50 controller': The housing covers of the 50 x 50 controllers are 50 x 50 mm in size. Using a 50 x 50 mm insert frame, they can be integrated into nearly all light switch ranges in accordance with DIN 49075. The 50 x 50 mm insert frames must be ordered from the light switch manufacturer or from a wholesaler. The order number of the insert frame corresponding to the switch range in question can be found in the column 'Only for adaptation with '50 x 50' cover set'.

'55 x 55 / 70 x 70 controller': The housing covers of the 55 x 55 / 70 x 70 controllers are 55 x 55 / 70 x 70 mm in size. Many light switch ranges have inner dimensions of 55 x 55 mm / 70 x 70 mm. Therefore, the 55 x 55 / 70 x 70 controllers can be installed directly in these light switch frames without the use of an insert frame. See the column 'Adaptation with '55 x 55 / 70 x 70' cover set' to determine whether the 55 x 55 / 70 x 70 controller fits in the given light switch model (x).

All information regarding switch manufacturers' product lines and item numbers was last updated in 12/2022 | No liability is assumed for the information provided. | TECHNICAL DATA subject to change.



PRODUCT FINDER ALRE COVER SETS

FOR SWITCH RANGES FROM BERKER

INTEGRATION EXAMPLES



RTBSU – in S. 1



RTBSU – in B. 3



RTBSU – in B. 7



RTBSU – in K. 1



RTBSU – in Arsys

TYPE ALRE	BERKER RANGE	COLOUR (RAL) / SURFACE FINISH	ALRE COVER SET	COVER SET ITEM NO.	INSERT FRAME 50X50*	EURO / PG
RTBSU-401.000#00	S. 1 / B. 3 / B. 7	polar white (RAL 9010) glossy	JZ-001.100 (55 x 55, glossy)	UN990050	not required	9.50 / I
RTBSU-401.002#00	S. 1 / B. 3 / B. 7	polar white (RAL 9010) matt	JZ-001.101 (55 x 55, matt)	UN990055	not required	9.50 / I
RTBSU-401.010#00	Arsys	polar white (RAL 9010) glossy	JZ-001.000 (50 x 50, glossy)	UN990035	1108 01 69	9.00 / I
RTBSU-401.086#00	Q. 1 / Q. 3	polar white (RAL 9010) velvet	JZ-001.001 (50 x 50, matt)	UN990040	1109 60 79	9.00 / I
RTBSU-401.202#00	K. 1	polar white (RAL 9010) glossy	JZ-001.000 (50 x 50, glossy)	UN990035	1108 71 09	9.00 / I
RTBSU-401.210#00	S. 1	white (RAL 1013) glossy	JZ-001.110 (55 x 55, glossy)	UN990060	not required	9.50 / I
	Arsys	white (RAL 1013) glossy	JZ-001.010 (50 x 50, glossy)	UN990045	1108 01 02	9.00 / I
Standard (without switch)						
RTBSU-401.034#00	S. 1 / B. 3 / B. 7	polar white (RAL 9010) glossy	JZ-016.100 (50 x 55 glossy)	UN990140	not required	9.70 / I
	Arsys	polar white (RAL 9010) glossy	JZ-016.000 (50 x 50 glossy)	UN990139	1108 01 69	9.20 / I
	K.	polar white (RAL 9010) glossy	JZ-016.000 (50 x 50 glossy)	UN990139	1108 71 09	9.20 / I
(LED)						
RTBSU-401.062#00	S. 1 / B. 3 / B. 7	polar white (RAL 9010) glossy	JZ-035.100 (55 x 55, glossy)	UN990173	not required	10.00 / I
RTBSU-401.262#00	S. 1 / B. 3 / B. 7	polar white (RAL 9010) matt	JZ-035.101 (55 x 55, matt)	UN990197	not required	10.00 / I
	Arsys	polar white (RAL 9010) glossy	JZ-035.000 (50 x 50, glossy)	UN990169	1108 01 69	9.50 / I
	Q. 1 / Q. 3	polar white (RAL 9010) velvet	JZ-035.001 (50 x 50, matt)	UN990193	1109 60 79	9.50 / I
	K. 1	polar white (RAL 9010) glossy	JZ-035.000 (50 x 50, glossy)	UN990169	1108 71 09	9.50 / I
	S. 1	white (RAL 1013) glossy	JZ-035.110 (55 x 55, glossy)	UN990181	not required	10.00 / I
	Arsys	white (RAL 1013) glossy	JZ-035.010 (50 x 50, glossy)	UN990177	1108 01 02	9.50 / I
(ON / OFF switch, LED)						
RTBSU-401.063#00	S. 1 / B. 3 / B. 7	polar white (RAL 9010) glossy	JZ-038.100 (55 x 55, glossy)	UN990174	not required	9.70 / I
	S. 1 / B. 3 / B. 7	polar white (RAL 9010) matt	JZ-038.101 (55 x 55, matt)	UN990198	not required	9.70 / I
	Arsys	polar white (RAL 9010) glossy	JZ-038.000 (50 x 50, glossy)	UN990170	1108 01 69	9.20 / I
	Q. 1 / Q. 3	polar white (RAL 9010) velvet	JZ-038.001 (50 x 50, matt)	UN990194	1109 60 79	9.20 / I
	K. 1	polar white (RAL 9010) glossy	JZ-038.000 (50 x 50, glossy)	UN990170	1108 71 09	9.20 / I
	S. 1	white (RAL 1013) glossy	JZ-038.110 (55 x 55, glossy)	UN990182	not required	9.70 / I
	Arsys	white (RAL 1013) glossy	JZ-038.010 (50 x 50, glossy)	UN990178	1108 01 02	9.20 / I
(Switch H / OFF / C)						
RTBSU-401.065#00	S. 1 / B. 3 / B. 7	polar white (RAL 9010) glossy	JZ-037.100 (55 x 55, glossy)	UN990175	not required	9.70 / I
RTBSU-401.265#00	S. 1 / B. 3 / B. 7	polar white (RAL 9010) matt	JZ-037.101 (55 x 55, matt)	UN990199	not required	9.70 / I
	Arsys	polar white (RAL 9010) glossy	JZ-037.000 (50 x 50, glossy)	UN990171	1108 01 69	9.20 / I
	Q. 1 / Q. 3	polar white (RAL 9010) velvet	JZ-037.001 (50 x 50, matt)	UN990195	1109 60 79	9.20 / I
	K. 1	polar white (RAL 9010) glossy	JZ-037.000 (50 x 50, glossy)	UN990171	1108 71 09	9.20 / I
	S. 1	white (RAL 1013) glossy	JZ-037.110 (55 x 55, glossy)	UN990183	not required	9.70 / I
	Arsys	white (RAL 1013) glossy	JZ-037.010 (50 x 50, glossy)	UN990179	1108 01 02	9.20 / I
(H / C switch)						
RTBSU-401.075#00	S. 1 / B. 3 / B. 7	polar white (RAL 9010) glossy	JZ-036.100 (55 x 55, glossy)	UN990176	not required	10.00 / I
	S. 1 / B. 3 / B. 7	polar white (RAL 9010) matt	JZ-036.101 (55 x 55, matt)	UN990200	not required	10.00 / I
	Arsys	polar white (RAL 9010) glossy	JZ-036.000 (50 x 50, glossy)	UN990172	1108 01 69	9.50 / I
	Q. 1 / Q. 3	polar white (RAL 9010) velvet	JZ-036.001 (50 x 50, matt)	UN990196	1109 60 79	9.50 / I
	K. 1	polar white (RAL 9010) glossy	JZ-036.000 (50 x 50, glossy)	UN990172	1108 71 09	9.50 / I
	S. 1	white (RAL 1013) glossy	JZ-036.110 (55 x 55, glossy)	UN990184	not required	10.00 / I
	Arsys	white (RAL 1013) glossy	JZ-036.010 (50 x 50, glossy)	UN990180	1108 01 02	9.50 / I
(3-way switch, LED)						

*) must be ordered from switch manufacturer or electronics wholesaler

PRODUCT FINDER ALRE COVER SETS FOR SWITCH RANGES FROM BUSCH-JAEGER

INTEGRATION EXAMPLES



RTBSU – in Reflex SI



RTBSU – in Busch-balance SI



RTBSU – in future linear



RTBSU – in solo



RTBSU – in alpha nea

TYPE ALRE	BUSCH-JAEGER RANGE	COLOUR (RAL)/ SURFACE FINISH	ALRE COVER SET	COVER SET ITEM NO.	INSERT FRAME 50X50*	EURO/ PG	
<p>Standard (without switch)</p>	RTBSU-401.000#00 RTBSU-401.002#00 RTBSU-401.010#00 RTBSU-401.086#00 RTBSU-401.202#00 RTBSU-401.210#00	Reflex SI / SI Linear	alpine white (RAL 9010) glossy	JZ-001.200 / BJ	G9990490	not required	9.50 / I
	Busch-balance SI	alpine white (RAL 9010) glossy	JZ-001.100 (55 x 55, glossy)	UN990050	not required	9.50 / I	
	impuls	alpine white (RAL 9010) glossy	JZ-001.000 (50 x 50, glossy)	UN990035	1746 / 10-74	9.00 / I	
	future linear / solo / axcent / carat	studio white (RAL 9016) glossy	JZ-001.320 / BJ	G9990493	not required	9.50 / I	
	future linear	studio white (RAL 9016) matt	JZ-001.021 (50 x 50, matt)	UN990100	1746 / 10-884	9.00 / I	
	alpha nea	studio white (RAL 9016) glossy	JZ-001.020 (50 x 50, glossy)	UN990071	1746 / 10-24G	9.00 / I	
	alpha nea	studio white (RAL 9016) matt	JZ-001.021 (50 x 50, matt)	UN990100	1746 / 10-24	9.00 / I	
	Duro 2000 SI / SI Linear	white (RAL 1013) glossy	JZ-001.210 / BJ	G9990491	not required	9.50 / I	
	future linear / solo / carat	ivory white (RAL 1013) glossy	JZ-001.010 (50 x 50, glossy)	UN990045	1746 / 10-82	9.00 / I	
	alpha nea	ivory white (RAL 1013) glossy	JZ-001.010 (50 x 50, glossy)	UN990045	1746 / 10-22G	9.00 / I	
impuls	ivory white (RAL 1013) glossy	JZ-001.010 (50 x 50, glossy)	UN990045	1746 / 10-72	9.00 / I		
<p>(LED)</p>	RTBSU-401.034#00	Busch-balance SI	alpine white (RAL 9010) glossy	JZ-016.100 (50 x 55 glossy)	UN990140	not required	9.70 / I
	impuls	alpine white (RAL 9010) glossy	JZ-016.000 (50 x 50 glossy)	UN990139	1746 / 10-74	9.20 / I	
<p>(ON / OFF switch, LED)</p>	RTBSU-401.062#00 RTBSU-401.262#00	Reflex SI / SI Linear	alpine white (RAL 9010) glossy	JZ-035.200 / BJ	G9990499	not required	10.00 / I
	Busch-balance SI	alpine white (RAL 9010) glossy	JZ-035.100 (55 x 55, glossy)	UN990173	not required	10.00 / I	
	impuls	alpine white (RAL 9010) glossy	JZ-035.000 (50 x 50, glossy)	UN990169	1746 / 10-74	9.50 / I	
	future linear / solo / axcent / carat	studio white (RAL 9016) glossy	JZ-035.020 (50 x 50, glossy)	UN990185	1746 / 10-84	9.50 / I	
	future linear	studio white (RAL 9016) matt	JZ-035.021 (50 x 50, matt)	UN990201	1746 / 10-884	9.50 / I	
	alpha nea	studio white (RAL 9016) glossy	JZ-035.020 (50 x 50, glossy)	UN990185	1746 / 10-24G	9.50 / I	
	alpha nea	studio white (RAL 9016) matt	JZ-035.021 (50 x 50, matt)	UN990201	1746 / 10-24	9.50 / I	
	Duro 2000 SI / SI Linear	white (RAL 1013) glossy	JZ-035.010 (50 x 50, glossy)	UN990177	1746-212-101	9.50 / I	
	future linear / solo / carat	ivory white (RAL 1013) glossy	JZ-035.010 (50 x 50, glossy)	UN990177	1746 / 10-82	9.50 / I	
	alpha nea	ivory white (RAL 1013) glossy	JZ-035.010 (50 x 50, glossy)	UN990177	1746 / 10-22G	9.50 / I	
impuls	ivory white (RAL 1013) glossy	JZ-035.010 (50 x 50, glossy)	UN990177	1746 / 10-72	9.50 / I		
<p>(Switch H / OFF / C)</p>	RTBSU-401.063#00	Reflex SI / SI Linear	alpine white (RAL 9010) glossy	JZ-038.000 (50 x 50, glossy)	UN990170	1746-214-101	9.20 / I
	Busch-balance SI	alpine white (RAL 9010) glossy	JZ-038.100 (55 x 55, glossy)	UN990174	not required	9.70 / I	
	impuls	alpine white (RAL 9010) glossy	JZ-038.000 (50 x 50, glossy)	UN990170	1746 / 10-74	9.20 / I	
	future linear / solo / axcent / carat	studio white (RAL 9016) glossy	JZ-038.020 (50 x 50, glossy)	UN990186	1746 / 10-84	9.20 / I	
	future linear	studio white (RAL 9016) matt	JZ-038.021 (50 x 50, matt)	UN990202	1746 / 10-884	9.20 / I	
	alpha nea	studio white (RAL 9016) glossy	JZ-038.020 (50 x 50, glossy)	UN990186	1746 / 10-24G	9.20 / I	
	alpha nea	studio white (RAL 9016) matt	JZ-038.021 (50 x 50, matt)	UN990202	1746 / 10-24	9.20 / I	
	Duro 2000 SI / SI Linear	white (RAL 1013) glossy	JZ-038.010 (50 x 50, glossy)	UN990178	1746-212-101	9.20 / I	
	future linear / solo / carat	ivory white (RAL 1013) glossy	JZ-038.010 (50 x 50, glossy)	UN990178	1746 / 10-82	9.20 / I	
	alpha nea	ivory white (RAL 1013) glossy	JZ-038.010 (50 x 50, glossy)	UN990178	1746 / 10-22G	9.20 / I	
impuls	ivory white (RAL 1013) glossy	JZ-038.010 (50 x 50, glossy)	UN990178	1746 / 10-72	9.20 / I		

PRODUCT FINDER ALRE COVER SETS FOR SWITCH RANGES FROM BUSCH-JAEGER

INTEGRATION EXAMPLES



RTBSU – in Reflex SI



RTBSU – in Busch-balance SI



RTBSU – in future linear



RTBSU – in solo



RTBSU – in alpha nea

TYPE ALRE	BUSCH-JAEGER RANGE	COLOUR (RAL)/ SURFACE FINISH	ALRE COVER SET	COVER SET ITEM NO.	INSERT FRAME 50X50*	EURO/ PG	
<p>(H / C switch)</p>	RTBSU-401.065#00 RTBSU-401.265#00	Reflex SI / SI Linear	alpine white (RAL 9010) glossy	JZ-037.000 (50 x 50, glossy)	UN990171	1746-214-101	9.20 / I
	Busch-balance SI	alpine white (RAL 9010) glossy	JZ-037.100 (55 x 55, glossy)	UN990175	not required	9.70 / I	
	impuls	alpine white (RAL 9010) glossy	JZ-037.000 (50 x 50, glossy)	UN990171	1746 / 10-74	9.20 / I	
	future linear / solo / axcent / carat	studio white (RAL 9016) glossy	JZ-037.020 (50 x 50, glossy)	UN990187	1746 / 10-84	9.20 / I	
	future linear	studio white (RAL 9016) matt	JZ-037.021 (50 x 50, matt)	UN990203	1746 / 10-884	9.20 / I	
	alpha nea	studio white (RAL 9016) glossy	JZ-037.020 (50 x 50, glossy)	UN990187	1746 / 10-24G	9.20 / I	
	alpha nea	studio white (RAL 9016) matt	JZ-037.021 (50 x 50, matt)	UN990203	1746 / 10-24	9.20 / I	
	Duro 2000 SI / SI Linear	white (RAL 1013) glossy	JZ-037.010 (50 x 50, glossy)	UN990179	1746-212-101	9.20 / I	
	future linear / solo / carat	ivory white (RAL 1013) glossy	JZ-037.010 (50 x 50, glossy)	UN990179	1746 / 10-82	9.20 / I	
	alpha nea	ivory white (RAL 1013) glossy	JZ-037.010 (50 x 50, glossy)	UN990179	1746 / 10-22G	9.20 / I	
impuls	ivory white (RAL 1013) glossy	JZ-037.010 (50 x 50, glossy)	UN990179	1746 / 10-72	9.20 / I		
<p>(3-way switch, LED)</p>	RTBSU-401.075#00	Reflex SI / SI Linear	alpine white (RAL 9010) glossy	JZ-036.000 (50 x 50, glossy)	UN990172	1746-214-101	9.50 / I
	Busch-balance SI	alpine white (RAL 9010) glossy	JZ-036.100 (55 x 55, glossy)	UN990176	not required	10.00 / I	
	impuls	alpine white (RAL 9010) glossy	JZ-036.000 (50 x 50, glossy)	UN990172	1746 / 10-74	9.50 / I	
	future linear / solo / axcent / carat	studio white (RAL 9016) glossy	JZ-036.020 (50 x 50, glossy)	UN990188	1746 / 10-84	9.50 / I	
	future linear	studio white (RAL 9016) matt	JZ-036.021 (50 x 50, matt)	UN990204	1746 / 10-884	9.50 / I	
	alpha nea	studio white (RAL 9016) glossy	JZ-036.020 (50 x 50, glossy)	UN990188	1746 / 10-24G	9.50 / I	
	alpha nea	studio white (RAL 9016) matt	JZ-036.021 (50 x 50, matt)	UN990204	1746 / 10-24	9.50 / I	
	Duro 2000 SI / SI Linear	white (RAL 1013) glossy	JZ-036.010 (50 x 50, glossy)	UN990180	1746-212-101	9.50 / I	
	future linear / solo / carat	ivory white (RAL 1013) glossy	JZ-036.010 (50 x 50, glossy)	UN990180	1746 / 10-82	9.50 / I	
	alpha nea	ivory white (RAL 1013) glossy	JZ-036.010 (50 x 50, glossy)	UN990180	1746 / 10-22G	9.50 / I	
impuls	ivory white (RAL 1013) glossy	JZ-036.010 (50 x 50, glossy)	UN990180	1746 / 10-72	9.50 / I		

*) must be ordered from switch manufacturer or electronics wholesaler
For BJ future / solo there are also 55 x 55 insert frames (for use with alre 55 x 55 cover set) – BJ item no. 1747-84 (studio white) and 1784-82 (ivory white)
Note: Busch-Jaeger central disc cannot be used with alre RTBSU.

PRODUCT FINDER ALRE COVER SETS

FOR SWITCH RANGES FROM ELSO

INTEGRATION EXAMPLES

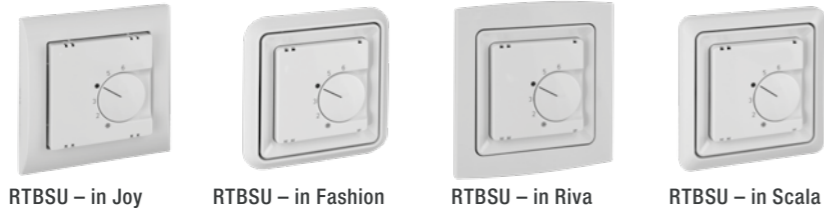

TYPE ALRE	ELSO RANGE	COLOUR (RAL)/ SURFACE FINISH	ALRE COVER SET	COVER SET ITEM NO.	INSERT FRAME 50X50*	EURO/ PG
RTBSU-401.000#00	Joy	pure white (RAL 9010) glossy	JZ-001.100 (55 x 55, glossy)	UN990050	not required	9.50/1
RTBSU-401.002#00	Joy	pearl white (RAL 1013) glossy	JZ-001.110 (55 x 55, glossy)	UN990060	not required	9.50/1
RTBSU-401.010#00	Joy	pearl white (RAL 1013) glossy	JZ-001.110 (55 x 55, glossy)	UN990060	not required	9.50/1
RTBSU-401.086#00	Fashion / Riva / Scala	pure white (RAL 9010) glossy	JZ-001.000 (50 x 50, glossy)	UN990035	203084	9.00/1
RTBSU-401.202#00	Fashion / Riva / Scala	pearl white (RAL 1013) glossy	JZ-001.010 (50 x 50, glossy)	UN990045	203080	9.00/1
RTBSU-401.210#00	Fashion / Riva / Scala	pearl white (RAL 1013) glossy	JZ-001.010 (50 x 50, glossy)	UN990045	203080	9.00/1
Standard (without switch)						
RTBSU-401.034#00	Joy	pure white (RAL 9010) glossy	JZ-016.100 (50 x 55 glossy)	UN990140	not required	9.70/1
	Fashion / Riva / Scala	pure white (RAL 9010) glossy	JZ-016.000 (50 x 50 glossy)	UN990139	203084	9.20/1
(LED)						
RTBSU-401.062#00	Joy	pure white (RAL 9010) glossy	JZ-035.100 (55 x 55, glossy)	UN990173	not required	10.00/1
RTBSU-401.262#00	Joy	pearl white (RAL 1013) glossy	JZ-035.110 (55 x 55, glossy)	UN990181	not required	10.00/1
	Fashion / Riva / Scala	pure white (RAL 9010) glossy	JZ-035.000 (50 x 50, glossy)	UN990169	203084	9.50/1
	Fashion / Riva / Scala	pearl white (RAL 1013) glossy	JZ-035.010 (50 x 50, glossy)	UN990177	203080	9.50/1
(ON / OFF switch, LED)						
RTBSU-401.063#00	Joy	pure white (RAL 9010) glossy	JZ-038.100 (55 x 55, glossy)	UN990174	not required	9.70/1
	Joy	pearl white (RAL 1013) glossy	JZ-038.110 (55 x 55, glossy)	UN990182	not required	9.70/1
	Fashion / Riva / Scala	pure white (RAL 9010) glossy	JZ-038.000 (50 x 50, glossy)	UN990170	203084	9.20/1
	Fashion / Riva / Scala	pearl white (RAL 1013) glossy	JZ-038.010 (50 x 50, glossy)	UN990178	203080	9.20/1
(Switch H / OFF / C)						
RTBSU-401.065#00	Joy	pure white (RAL 9010) glossy	JZ-037.100 (55 x 55, glossy)	UN990175	not required	9.70/1
RTBSU-401.265#00	Joy	pearl white (RAL 1013) glossy	JZ-037.110 (55 x 55, glossy)	UN990183	not required	9.70/1
	Fashion / Riva / Scala	pure white (RAL 9010) glossy	JZ-037.000 (50 x 50, glossy)	UN990171	203084	9.20/1
	Fashion / Riva / Scala	pearl white (RAL 1013) glossy	JZ-037.010 (50 x 50, glossy)	UN990179	203080	9.20/1
(H / C switch)						
RTBSU-401.075#00	Joy	pure white (RAL 9010) glossy	JZ-036.100 (55 x 55, glossy)	UN990176	not required	10.00/1
	Joy	pearl white (RAL 1013) glossy	JZ-036.110 (55 x 55, glossy)	UN990184	not required	10.00/1
	Fashion / Riva / Scala	pure white (RAL 9010) glossy	JZ-036.000 (50 x 50, glossy)	UN990172	203084	9.50/1
	Fashion / Riva / Scala	pearl white (RAL 1013) glossy	JZ-036.010 (50 x 50, glossy)	UN990180	203080	9.50/1
(3-way switch, LED)						

*) must be ordered from switch manufacturer or electronics wholesaler

PRODUCT FINDER ALRE COVER SETS

FOR SWITCH RANGES FROM GIRA

INTEGRATION EXAMPLES



TYPE ALRE	GIRA RANGE	COLOUR (RAL)/ SURFACE FINISH	ALRE COVER SET	COVER SET ITEM NO.	INSERT FRAME 50X50*	EURO/ PG
RTBSU-401.000#00	Standard 55 / E 2 / E 22 / Event / Esprit	pure white (RAL 9010) glossy	JZ-001.100 (55 x 55, glossy)	UN990050	not required	9.50/1
RTBSU-401.002#00	Standard 55 / E 2 / E 22 / Event / Esprit	pure white (RAL 9010) matt	JZ-001.101 (55 x 55, matt)	UN990055	not required	9.50/1
RTBSU-401.010#00	Standard 55 / E 2 / E 22 / Event / Esprit	pure white (RAL 9010) matt	JZ-001.101 (55 x 55, matt)	UN990055	not required	9.50/1
RTBSU-401.086#00	Surface switch NEW	pure white (RAL 9010) glossy	JZ-001.400 (70 x 70, glossy)	UN990141	not required	9.50/1
RTBSU-401.202#00	Standard 55 / Event / Esprit / ClassiX	cream white (RAL 1013) glossy	JZ-001.110 (55 x 55, glossy)	UN990060	not required	9.50/1
RTBSU-401.210#00	System 55	anthracite / matt	JZ-001.141 / GI	UN990111	not required	20.30/1
Standard (without switch)						
RTBSU-401.034#00	Standard 55 / E 2 / E 3 / E 22 / Event / Esprit	pure white (RAL 9010) glossy	JZ-016.100 (50 x 55 glossy)	UN990140	not required	9.70/1
	Surface switch NEW	pure white (RAL 9010) glossy	JZ-016.400 (70 x 70, glossy)	UN990142	not required	9.70/1
(LED)						
RTBSU-401.062#00	Standard 55 / E 2 / E 22 / Event / Esprit	pure white (RAL 9010) glossy	JZ-035.100 (55 x 55, glossy)	UN990173	not required	10.00/1
RTBSU-401.262#00	Standard 55 / E 2 / E 22 / Event / Esprit	pure white (RAL 9010) matt	JZ-035.101 (55 x 55, matt)	UN990197	not required	10.00/1
	Surface switch NEW	pure white (RAL 9010) glossy	JZ-035.400 (70 x 70, glossy)	UN990143	not required	10.00/1
	Standard 55 / Event / Esprit / ClassiX	cream white (RAL 1013) glossy	JZ-035.110 (55 x 55, glossy)	UN990181	not required	10.00/1
(ON / OFF switch, LED)						
RTBSU-401.063#00	Standard 55 / E 2 / E 22 / Event / Esprit	pure white (RAL 9010) glossy	JZ-038.100 (55 x 55, glossy)	UN990174	not required	9.70/1
	Standard 55 / E 2 / E 22 / Event / Esprit	pure white (RAL 9010) matt	JZ-038.101 (55 x 55, matt)	UN990198	not required	9.70/1
	surface switch	pure white (RAL 9010) glossy	JZ-038.000 (50 x 50, glossy)	UN990170	0282 112	9.20/1
	Standard 55 / Event / Esprit / ClassiX	cream white (RAL 1013) glossy	JZ-038.110 (55 x 55, glossy)	UN990182	not required	9.70/1
(Switch H / OFF / C)						
RTBSU-401.065#00	Standard 55 / E 2 / E 22 / Event / Esprit	pure white (RAL 9010) glossy	JZ-037.100 (55 x 55, glossy)	UN990175	not required	9.70/1
RTBSU-401.265#00	Standard 55 / E 2 / E 22 / Event / Esprit	pure white (RAL 9010) matt	JZ-037.101 (55 x 55, matt)	UN990199	not required	9.70/1
	Surface switch NEW	pure white (RAL 9010) glossy	JZ-037.400 (70 x 70, glossy)	UN990144	not required	9.70/1
	Standard 55 / Event / Esprit / ClassiX	cream white (RAL 1013) glossy	JZ-037.110 (55 x 55, glossy)	UN990183	not required	9.70/1
(H / C switch)						
RTBSU-401.075#00	Standard 55 / E 2 / E 22 / Event / Esprit	pure white (RAL 9010) glossy	JZ-036.100 (55 x 55, glossy)	UN990176	not required	10.00/1
	Standard 55 / E 2 / E 22 / Event / Esprit	pure white (RAL 9010) matt	JZ-036.101 (55 x 55, matt)	UN990200	not required	10.00/1
	surface switch	pure white (RAL 9010) glossy	JZ-036.000 (50 x 50, glossy)	UN990172	0282 40	9.50/1
	Standard 55 / Event / Esprit / ClassiX	cream white (RAL 1013) glossy	JZ-036.110 (55 x 55, glossy)	UN990184	not required	10.00/1
(3-way switch, LED)						

*) must be ordered from switch manufacturer or electronics wholesaler

***) for GIRA surface switches, there are also 55 x 55 insert frames (for the use of alre 55 x 55 cover set) – GIRA item no. 0289 112 (pure white) and 0289 111 (cream white)

PRODUCT FINDER ALRE COVER SETS FOR SWITCH RANGES FROM JUNG

INTEGRATION EXAMPLES



TYPE ALRE	JUNG RANGE	COLOUR (RAL)/ SURFACE FINISH	ALRE COVER SET	COVER SET ITEM NO.	INSERT FRAME 50X50*	EURO/ PG	
RTBSU-401.000#00 RTBSU-401.002#00 RTBSU-401.010#00 RTBSU-401.086#00 RTBSU-401.202#00 RTBSU-401.210#00	AS 500/A 500/A 550/A creation/A plus/A flow	alpine white (RAL 9010) glossy	JZ-001.100 (55 x 55, glossy)	UN990050	not required	9.50/I	
	CD 500/CD plus	alpine white (RAL 9010) glossy	JZ-001.000 (50 x 50, glossy)	UN990035	CD 590 Z WW	9.00/I	
	LS 990/LS design/LS plus NEW	alpine white (RAL 9010) glossy	JZ-001.400 (70 x 70, glossy)	UN990141	not required	9.50/I	
	AS 500	white (RAL 1013) glossy	JZ-001.110 (55 x 55, glossy)	UN990060	not required	9.50/I	
	CD 500/CD plus	white (RAL 1013) glossy	JZ-001.010 (50 x 50, glossy)	UN990045	590 Z	9.00/I	
Standard (without switch)	LS 990/LS design/LS plus NEW	white (RAL 1013) glossy	JZ-001.410 (70 x 70, glossy)	UN990145	not required	9.50/I	
	AS 550/A flow	snow white matt	JZ-001.101 (55 x 55, matt)	UN990055	not required	9.50/I	
	RTBSU-401.034#00	AS 500/A 500/A 550/A creation/A plus/A flow	alpine white (RAL 9010) glossy	JZ-016.100 (55 x 55, glossy)	UN990140	not required	9.70/I
(LED)	CD 500/CD plus	alpine white (RAL 9010) glossy	JZ-016.000 (50 x 50, glossy)	UN990139	CD 590 Z WW	9.20/I	
	LS 990/LS design/LS plus NEW	alpine white (RAL 9010) glossy	JZ-016.400 (70 x 70, glossy)	UN990142	not required	9.70/I	
	RTBSU-401.062#00 RTBSU-401.262#00	AS 500/A 500/A 550/A creation/A plus/A flow	alpine white (RAL 9010) glossy	JZ-035.100 (55 x 55, glossy)	UN990173	not required	10.00/I
(ON/OFF switch, LED)	CD 500/CD plus	alpine white (RAL 9010) glossy	JZ-035.000 (50 x 50, glossy)	UN990169	CD 590 Z WW	9.50/I	
	LS 990/LS design/LS plus NEW	alpine white (RAL 9010) glossy	JZ-035.400 (70 x 70, glossy)	UN990143	not required	10.00/I	
	AS 500	white (RAL 1013) glossy	JZ-035.110 (55 x 55, glossy)	UN990181	not required	10.00/I	
	CD 500/CD plus	white (RAL 1013) glossy	JZ-035.010 (50 x 50, glossy)	UN990177	590 Z	9.50/I	
	LS 990/LS design/LS plus NEW	white (RAL 1013) glossy	JZ-035.410 (70 x 70, glossy)	UN990147	not required	10.00/I	
AS 550/A flow	AS 550/A flow	snow white matt	JZ-035.101 (55 x 55, matt)	UN990197	not required	10.00/I	
	RTBSU-401.063#00	AS 500/A 500/A 550/A creation/A plus/A flow	alpine white (RAL 9010) glossy	JZ-038.100 (55 x 55, glossy)	UN990174	not required	9.70/I
	(Switch H/OFF/C)	CD 500/CD plus	alpine white (RAL 9010) glossy	JZ-038.000 (50 x 50, glossy)	UN990170	CD 590 Z WW	9.20/I
		LS 990/LS design/LS plus	alpine white (RAL 9010) glossy	JZ-038.000 (50 x 50, glossy)	UN990170	LS 961 Z WW**	9.20/I
		AS 500	white (RAL 1013) glossy	JZ-038.110 (55 x 55, glossy)	UN990182	not required	9.70/I
CD 500/CD plus		white (RAL 1013) glossy	JZ-038.010 (50 x 50, glossy)	UN990178	590 Z	9.20/I	
LS 990/LS design/LS plus		white (RAL 1013) glossy	JZ-038.010 (50 x 50, glossy)	UN990178	LS 961 Z**	9.20/I	
AS 550/A flow	AS 550/A flow	snow white matt	JZ-038.101 (55 x 55, matt)	UN990198	not required	9.70/I	
	RTBSU-401.065#00 RTBSU-401.265#00	AS 500/A 500/A 550/A creation/A plus/A flow	alpine white (RAL 9010) glossy	JZ-037.100 (55 x 55, glossy)	UN990175	not required	9.70/I
	(H/C switch)	CD 500/CD plus	alpine white (RAL 9010) glossy	JZ-037.000 (50 x 50, glossy)	UN990171	CD 590 Z WW	9.20/I
		LS 990/LS design/LS plus NEW	alpine white (RAL 9010) glossy	JZ-037.400 (70 x 70, glossy)	UN990144	not required	9.70/I
		AS 500	white (RAL 1013) glossy	JZ-037.110 (55 x 55, glossy)	UN990183	not required	9.70/I
CD 500/CD plus		white (RAL 1013) glossy	JZ-037.010 (50 x 50, glossy)	UN990179	590 Z	9.20/I	
LS 990/LS design/LS plus NEW		white (RAL 1013) glossy	JZ-037.410 (70 x 70, glossy)	UN990148	not required	9.70/I	
AS 550/A flow	AS 550/A flow	snow white matt	JZ-037.101 (55 x 55, matt)	UN990199	not required	9.70/I	
	RTBSU-401.075#00	AS 500/A 500/A 550/A creation/A plus/A flow	alpine white (RAL 9010) glossy	JZ-036.100 (55 x 55, glossy)	UN990176	not required	10.00/I
	(3-way switch, LED)	CD 500/CD plus	alpine white (RAL 9010) glossy	JZ-036.000 (50 x 50, glossy)	UN990172	CD 590 Z WW	9.50/I
		LS 990/LS design/LS plus	alpine white (RAL 9010) glossy	JZ-036.000 (50 x 50, glossy)	UN990172	LS 961 Z WW**	9.50/I
		AS 500	white (RAL 1013) glossy	JZ-036.110 (55 x 55, glossy)	UN990184	not required	10.00/I
CD 500/CD plus		white (RAL 1013) glossy	JZ-036.010 (50 x 50, glossy)	UN990180	590 Z	9.50/I	
LS 990/LS design/LS plus		white (RAL 1013) glossy	JZ-036.010 (50 x 50, glossy)	UN990180	LS 961 Z**	9.50/I	
AS 550/A flow	AS 550/A flow	snow white matt	JZ-036.101 (55 x 55, matt)	UN990200	not required	10.00/I	

*) must be ordered from switch manufacturer or electronics wholesaler
 *** if necessary, the manufacturer JUNG will change the colour of alpine white from RAL 9010 to RAL 9016

PRODUCT FINDER ALRE COVER SETS FOR SWITCH RANGES FROM MERTEN

INTEGRATION EXAMPLES



TYPE ALRE	MERTEN RANGE	COLOUR (RAL)/ SURFACE FINISH	ALRE COVER SET	COVER SET ITEM NO.	INSERT FRAME 50X50*	EURO/ PG	
RTBSU-401.000#00 RTBSU-401.002#00 RTBSU-401.010#00 RTBSU-401.086#00 RTBSU-401.202#00 RTBSU-401.210#00	1-M, Atelier-M/M-Smart, M-Pure, M-Plan, M-Creativ	polar white (RAL 9010) glossy	JZ-001.100 (55 x 55, glossy)	UN990050	not required	9.50/I	
	1-M, Atelier-M/M-Smart, M-Pure, M-Plan, M-Creativ	polar white (RAL 9010) matt	JZ-001.101 (55 x 55, matt)	UN990055	not required	9.50/I	
	1-M, Atelier-M/M-Smart, M-Pure, M-Plan, M-Creativ	active white (RAL 9016) glossy	JZ-001.120 (55 x 55, glossy)	UN990086	not required	9.50/I	
	D-Life NEW	lotus white (RAL 9016) glossy	JZ-001.420 (70 x 70, glossy)	UN990149	not required	9.50/I	
	System design: Artec, Antik	polar white (RAL 9010) glossy	JZ-001.000 (50 x 50, glossy)	UN990035	5160 99	9.00/I	
Standard (without switch)	1-M, Atelier-M/M-Smart, M-Pure, M-Plan, M-Creativ	white (RAL 1013) glossy	JZ-001.110 (55 x 55, glossy)	UN990060	not required	9.50/I	
	System design: Artec, Antik	white (RAL 1013) glossy	JZ-001.010 (50 x 50, glossy)	UN990045	5160 94	9.00/I	
	RTBSU-401.034#00	1-M, Atelier-M/M-Smart, M-Pure, M-Plan, M-Creativ	polar white (RAL 9010) glossy	JZ-016.100 (55 x 55, glossy)	UN990140	not required	9.70/I
(LED)	System design: Artec, Antik	polar white (RAL 9010) glossy	JZ-016.000 (50 x 50, glossy)	UN990139	5160 99	9.20/I	
	D-Life NEW	lotus white (RAL 9016) glossy	JZ-016.420 (70 x 70, glossy)	UN990150	not required	9.70/I	
	RTBSU-401.062#00 RTBSU-401.262#00	1-M, Atelier-M/M-Smart, M-Pure, M-Plan, M-Creativ	polar white (RAL 9010) glossy	JZ-035.100 (55 x 55, glossy)	UN990173	not required	10.00/I
(ON/OFF switch, LED)	1-M, Atelier-M/M-Smart, M-Pure, M-Plan, M-Creativ	polar white (RAL 9010) matt	JZ-035.101 (55 x 55, matt)	UN990197	not required	10.00/I	
	1-M, Atelier-M/M-Smart, M-Pure, M-Plan, M-Creativ	active white (RAL 9016) glossy	JZ-035.120 (55 x 55, glossy)	UN990189	not required	10.00/I	
	D-Life NEW	lotus white (RAL 9016) glossy	JZ-035.420 (70 x 70, glossy)	UN990151	not required	10.00/I	
	System design: Artec, Antik	polar white (RAL 9010) glossy	JZ-035.000 (50 x 50, glossy)	UN990169	5160 99	9.50/I	
	1-M, Atelier-M/M-Smart, M-Pure, M-Plan, M-Creativ	white (RAL 1013) glossy	JZ-035.110 (55 x 55, glossy)	UN990181	not required	10.00/I	
System design: Artec, Antik	System design: Artec, Antik	white (RAL 1013) glossy	JZ-035.010 (50 x 50, glossy)	UN990177	5160 94	9.50/I	
	RTBSU-401.063#00	1-M, Atelier-M/M-Smart, M-Pure, M-Plan, M-Creativ	polar white (RAL 9010) glossy	JZ-038.100 (55 x 55, glossy)	UN990174	not required	9.70/I
	(Switch H/OFF/C)	1-M, Atelier-M/M-Smart, M-Pure, M-Plan, M-Creativ	polar white (RAL 9010) matt	JZ-038.101 (55 x 55, matt)	UN990198	not required	9.70/I
		1-M, Atelier-M/M-Smart, M-Pure, M-Plan, M-Creativ	active white (RAL 9016) glossy	JZ-038.120 (55 x 55, glossy)	UN990190	not required	9.70/I
		D-Life	lotus white (RAL 9016) glossy	JZ-038.020 (50 x 50, glossy)	UN990186	MEG4500-6035	9.20/I
System design: Artec, Antik		polar white (RAL 9010) glossy	JZ-038.000 (50 x 50, glossy)	UN990170	5160 99	9.20/I	
1-M, Atelier-M/M-Smart, M-Pure, M-Plan, M-Creativ		white (RAL 1013) glossy	JZ-038.110 (55 x 55, glossy)	UN990182	not required	9.70/I	
System design: Artec, Antik	System design: Artec, Antik	white (RAL 1013) glossy	JZ-038.010 (50 x 50, glossy)	UN990178	5160 94	9.20/I	
	RTBSU-401.065#00 RTBSU-401.265#00	1-M, Atelier-M/M-Smart, M-Pure, M-Plan, M-Creativ	polar white (RAL 9010) glossy	JZ-037.100 (55 x 55, glossy)	UN990175	not required	9.70/I
	(H/C switch)	1-M, Atelier-M/M-Smart, M-Pure, M-Plan, M-Creativ	polar white (RAL 9010) matt	JZ-037.101 (55 x 55, matt)	UN990199	not required	9.70/I
		1-M, Atelier-M/M-Smart, M-Pure, M-Plan, M-Creativ	active white (RAL 9016) glossy	JZ-037.120 (55 x 55, glossy)	UN990191	not required	9.70/I
		D-Life NEW	lotus white (RAL 9016) glossy	JZ-037.420 (70 x 70, glossy)	UN990150	not required	9.70/I
System design: Artec, Antik		polar white (RAL 9010) glossy	JZ-037.000 (50 x 50, glossy)	UN990171	5160 99	9.20/I	
1-M, Atelier-M/M-Smart, M-Pure, M-Plan, M-Creativ		white (RAL 1013) glossy	JZ-037.110 (55 x 55, glossy)	UN990183	not required	9.70/I	
System design: Artec, Antik	System design: Artec, Antik	white (RAL 1013) glossy	JZ-037.010 (50 x 50, glossy)	UN990179	5160 94	9.20/I	
	RTBSU-401.075#00	1-M, Atelier-M/M-Smart, M-Pure, M-Plan, M-Creativ	polar white (RAL 9010) glossy	JZ-036.100 (55 x 55, glossy)	UN990176	not required	10.00/I
	(3-way switch, LED)	1-M, Atelier-M/M-Smart, M-Pure, M-Plan, M-Creativ	polar white (RAL 9010) matt	JZ-036.101 (55 x 55, matt)	UN990200	not required	10.00/I
		1-M, Atelier-M/M-Smart, M-Pure, M-Plan, M-Creativ	active white (RAL 9016) glossy	JZ-036.120 (55 x 55, glossy)	UN990192	not required	10.00/I
		D-Life	lotus white (RAL 9016) glossy	JZ-036.020 (50 x 50, glossy)	UN990188	MEG4500-6035	9.50/I
System design: Artec, Antik		polar white (RAL 9010) glossy	JZ-036.000 (50 x 50, glossy)	UN990172	5160 99	9.50/I	
1-M, Atelier-M/M-Smart, M-Pure, M-Plan, M-Creativ		white (RAL 1013) glossy	JZ-036.110 (55 x 55, glossy)	UN990184	not required	10.00/I	
System design: Artec, Antik	System design: Artec, Antik	white (RAL 1013) glossy	JZ-036.010 (50 x 50, glossy)	UN990180	5160 94	9.50/I	

*) must be ordered from switch manufacturer or electronics wholesaler
 Note: Merten central plates cannot be used with alre RTBSU.

ROOM TEMPERATURE CONTROLLER ELECTRONIC HTRRUT

FLUSH-MOUNTED



TECHNICAL DATA



Design:	Berlin flush-mounted
Housing material:	PC plastic
Ambient temperature:	0 to 40 °C
Storage temperature:	-20 to +70 °C
Permissible atmospheric humidity:	Max. 95% rel. humidity, non-condensing
Electrical connection:	pluggable screw terminals
Mounting/attachment:	in flush-mounted socket – can be adapted to many surface switch ranges (deep flush-mounted socket recommended)
Protection rating:	IP30
Protection class:	II, if properly mounted
Safety and EMC:	according to DIN EN 60730
Average power consumption:	< 0.5 W
Maximum switching current:	1 A
Switching element:	relay
Switching contact:	NO contact
Output signal:	switching, 230 VAC, 50 Hz
Sensor:	NTC, internal
Control range:	17 to 26 °C
Setting range:	5 to 26 °C
Hysteresis:	< approx. 0.5 K at a temperature change of max. 4 K/h

APPLICATION

temperature control and monitoring in offices, homes and hotels, can be connected directly to the valve actuators for hot water heating systems.

Valve actuator: normally closed. Up to max. 10 actuators for valves can be connected.

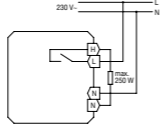
The HTRRUT-210.A00#55 controller fits perfectly into many switch ranges.

TYPE/IMAGE	ITEM NO.	FEATURES	CIRCUIT DIAGRAM	EURO/PG
	HTRRUT-210.A00#55 UA120000	General features: Controller with 55 x 55 mm cover, pure white (similar to RAL 9010), glossy		148.50/1
	HTRRUT-210.A00#31 UA120001	as HTRRUT-210.A00#55 but complete device with alre frame 'Berlin', pure white (similar to RAL 9010), glossy		152.00/1

ACCESSORIES	ITEM NO.	FEATURES	EURO/PG
	JZ-090.100 VV000048	General features: alre frame 'Berlin' (neutral) for all flush-mounted controllers with 55 x 55 mm cover Surface finish: glossy Colour: pure white, similar to RAL 9010 Material: PC plastic	4.80/1

ILLUSTRATIONS

Dimension schematic

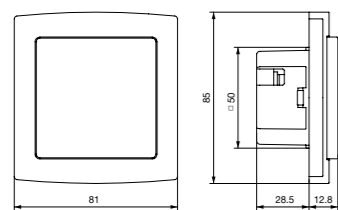

Temperature scale

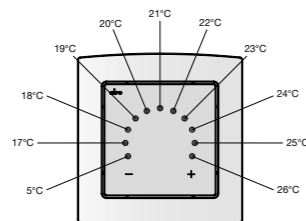

pluggable screw-type terminals

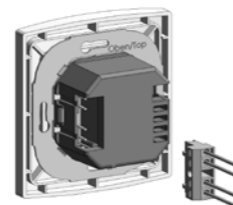

ADAPTATION OF ALRE FLUSH-MOUNTED CONTROLLERS

MANUFACTURER	RANGE	COLOUR RAL 9010 (surface finish)
BERKER	S.1	polar white (glossy)
BERKER	B.3	aluminium / polar white (glossy)
BERKER	B.7	glass / polar white (glossy)
BUSCH-JAEGER	Busch-balance SI	alpine white (glossy)
Eiso	Joy	pure white (glossy)
GIRA	surface switch	pure white (glossy)
GIRA (System 55)	Standard / E2 / E3	pure white (glossy)
GIRA (System 55)	E22	pure white (glossy)
GIRA (System 55)	Event	pure white (glossy) + opaque...
GIRA (System 55)	Esprit	pure white (glossy) + glass, aluminium...
JUNG	A 500 / A 550 / AS 500 / A plus / A flow	alpine white (glossy)
JUNG	LS 990	alpine white (glossy)
JUNG	LS plus	alpine white (glass)
JUNG	A creation	alpine white (glossy)
JUNG	LS Design	alpine white (glossy)
MERTEN (System M)	M-Smart, M-Plan, M-Creativ, M-Pure	polar white (glossy)
MERTEN (System Basis)	1-M / Atelier-M	polar white (glossy)

NOTE: Most switch ranges are designed in the colour 'similar to RAL 9010', although different switch manufacturers use different designations for this colour. Coloured, glass and aluminium frames are also combined with white jacks or plugs so that controllers with white covers can also be integrated into these frames. Check the precise application in each individual case. The frames have different surface qualities (matt/glossy). For design reasons, the cover of the controller should have the same quality as the frame. We accept no liability for slight variations in colour and surface finish or for accuracy of fit. When installing devices into multi frames, always assemble the temperature controllers at the lowermost position.

All information regarding switch manufacturers' product lines and item numbers was last updated in 12/2022 | No liability is assumed for the information provided. | TECHNICAL DATA subject to change.



ROOM TEMPERATURE OR FLOOR TEMPERATURE CONTROLLER ELECTRONIC WITH CLOCK HTRRUU

FLUSH-MOUNTED INSTALLATION – DESIGN BERLIN FLUSH-MOUNTED

**TECHNICAL DATA**

Design:	Berlin flush-mounted
Housing material:	PC, PMMA, ABS plastic
Operating voltage:	230 V AC, 50 Hz
Storage temperature:	-20 to +70 °C
Permissible atmospheric humidity:	Max. 95% rel. humidity, non-condensing
Electrical connection:	pluggable screw terminals
Mounting/attachment:	in flush-mounted socket, can be adapted to fit virtually any switch range (deep flush-mounted socket recommended) see adaptation list page 95
Protection rating:	IP30
Protection class:	II, if properly mounted
Safety and EMC:	according to DIN EN 60730
Max. switching current:	10 (2) A
Max. switching voltage:	230 V AC, 50 Hz
Min. switching voltage:	230 V AC, 50 Hz
Switching power:	2300 W
Switching element:	relay
Switching contact:	NO contact
Output signal:	230 V AC, 50 Hz
Sensor:	NTC internal, optional external floor sensor see 'Accessories', optional external room sensor see 'Sensor technology' 'Sensor 2'
Sensor rupture and short-circuit protection:	If the internal or external sensor is faulty or the external sensor is not connected to the functions room temperature controller with floor monitoring, floor temperature controller or room temperature controller with ext. sensor, emergency operation is triggered.
Control function:	heating
Control range:	5 to 30 °C (room) / 10 to 42 °C (floor)
Setting range:	The setting range varies, depending on the use of the controller as a room temperature controller (5 to 30 °C) or floor temperature controller (10 to 42 °C)
Hysteresis:	for room control < 1 K, for floor control < 1 K
Display type:	illuminated graphical display
Display:	setpoint, actual temperature / date, time; setpoint, actual temperature or date, time
Accessories:	terminal strips: VOOPL suitable valve actuators: ZB00A-010.1xx

APPLICATION

Flush-mounted controller for time-dependent single room or floor temperature control for electrical and hot water heating systems (normally closed actuators). The device can be used as a room temperature controller with internal sensor or (in combination with an optional remote sensor) as a room temperature controller with floor monitoring or floor temperature controller. (Remote sensor is not a part of the scope of delivery)

This clock thermostat has a weekly timer with individually adjustable programs (factory setting: 'normal' daily sequences).

Self-learning function: Automatic adjustment of the controller to the start of the heating period. The goal is to achieve the comfort temperature at the time that has been set. The learning function is disabled upon delivery, but it can be enabled.

Standby function: This function disables the control; frost protection is still ensured.

General features: ECO function, adjustable ECO value; 'ECO' display; 'on / off' display; 'heating' display; digital actual value display; backlighting; standby mode with frost protection monitoring; child-safe features; load setting; power reserve (approx. 5 days); Actual value correction / measured value correction; learning function; valve protection;

holiday setting; party setting; external setting; comfortable operation using touch-sensitive buttons; VDE-tested

Special colours as well as the colours anthracite and aluminium are available for projects upon request.



TYPE/IMAGE	ITEM NO.	FEATURES	CIRCUIT DIAGRAM	EURO/PG
	UA060000	Scope of delivery: controller, 50 x 50 mm cover, pure white (similar to RAL 9010), glossy, alre frame 'Berlin'		235.40 / I
	UA060001	Similar to HTRRUu 210.021#21 but scope of delivery as follows: controller, 50 x 50 mm cover pure white (similar to RAL 9010), glossy, without frame		230.90 / I

TYPE/IMAGE	ITEM NO.	FEATURES	CIRCUIT DIAGRAM	EURO/PG
	UA060002	Similar to HTRRUu 210.021#21 but scope of delivery as follows: controller, 50 x 50 mm cover pearl white (similar to RAL 1013), glossy, without frame		230.90 / I
	UA060003	Similar to HTRRUu 210.021#21 but scope of delivery as follows: controller, 50 x 50 mm cover traffic / studio white (similar to RAL 9016), glossy, without frame		230.90 / I
	UA060006	Similar to HTRRUu 210.021#21 but scope of delivery as follows: controller, cover suitable for BUSCH JAEGER Reflex SI / SI Linear pure white (similar to RAL 9010), glossy, without frame		232.70 / I
	UA060004	Similar to HTRRUu 210.021#21 but scope of delivery as follows: controller, 55 x 55 mm cover pure white (similar to RAL 9010), glossy, without frame		232.70 / I
	UA060020	Similar to HTRRUu 210.021#21 but scope of delivery as follows: controller, 55 x 55 mm cover, pure white (similar to RAL 9010), mat, without a frame		232.70 / I
	UA060005	Similar to HTRRUu 210.021#21 but scope of delivery as follows: controller, 55 x 55 mm cover pearl white (similar to RAL 1013), glossy, without frame		232.70 / I
	UA060014	Similar to HTRRUu 210.021#21 but scope of delivery as follows: controller, 55 x 55 mm cover traffic / studio white (similar to RAL 9016), glossy, without frame		232.70 / I

ACCESSORIES	ITEM NO.	FEATURES	EURO/PG
	G8000370	General features: optional, external floor sensor Ambient temperature: -5 to +70 °C Protection rating: IP65 Sensor: NTC Connecting cable: 4 m, PVC	26.50 / II
	G8000368	General features: optional, external floor sensor Ambient temperature: -5 to +70 °C Protection rating: IP65 Sensor: NTC Connecting cable: 6 m, PVC	29.50 / II
	G9990180	General features: Heat conduction paste 2 ml; R > 1 TΩ/cm, silicone-free Ambient temperature: -40 to +150 °C Heat conductivity: > 0.7 W/mK	7.70 / II
	C1809515	General features: protective sleeve for screed mounting (for sleeve sensor HF Ø 7.7, for example, HF-8/4-K2 or HF-8/6-K2), copper	45.00 / II
	VV000025	General features: alre frame 'Berlin' (neutral) for all flush-mounted controllers with 50 x 50 mm cover Design: Berlin Surface finish: glossy Colour: Pure white, similar to RAL 9010 Material: PC plastic	4.80 / I

ROOM TEMPERATURE OR FLOOR TEMPERATURE CONTROLLER, ELECTRONIC, WITH CLOCK HTRRUU

FLUSH-MOUNTED INSTALLATION – DESIGN BERLIN FLUSH-MOUNTED

ACCESSORIES	ITEM NO.	FEATURES	EURO/PG
	VV000048	Features: similar to JZ-090.900 but for all flush-mounted controllers in combination with 55 x 55 mm cover Surface finish: glossy Colour: pure white, similar to RAL 9010 Material: PC plastic	4.80 / I
	VV000010	General features: alre frame 'Berlin' (neutral) for all flush-mounted controllers with 50 x 50 mm cover Design: Berlin Surface finish: glossy Colour: pearl white, similar to RAL 1013 Material: PC plastic	4.80 / I
BTF2-C47-0000	SA140014	Surface-mounted 'ultra-thin' room temperature sensor for temperature measurement in residential and business premises (see also 'Sensor technology' section page 210)	30.10 / III
FUFC 47-0000	SN090198	Flush-mounted room temperature sensor for temperature measurement in residential and business premises (see also 'Sensor technology' section page 211)	38.10 / III

ILLUSTRATIONS

HTRRUu with alre frame 'Berlin'

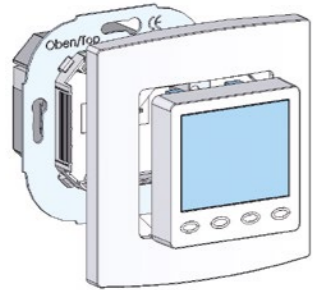

Pluggable screw-type terminals

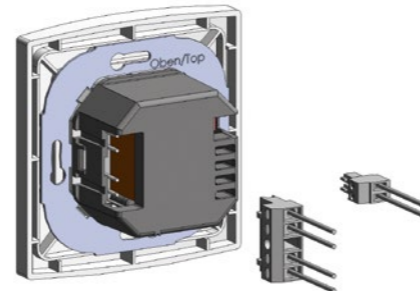

additional benefits:

- Pluggable screw-type terminals facilitate quick and easy assembly
- Illuminated, graphics-capable display
- Choice of 8 different external floor sensors (e.g., 2 kOhm – alre, 12 kOhm – OJ/AEG, 15 kOhm – DEVI, 33 kOhm – Eberle), meaning they are also ideal for retrofitting
- VDE mark
- Automatic adjustment to standard/daylight saving time
- Learn function
- Correction of measurement values
- Open window detection
- Configurable display content during installation, choice of various languages including German, English, French, Dutch, Polish, Spanish, Czech, Russian, Italian and Hungarian
- Limit setting for floor temperature
- Standby with frost protection
- Key lock
- Valve protection function
- Configurable control method (PI-PWM or 2-point control)
- Holiday and party function
- Power reserve
- 'Heating mode' indication (orange LED)
- Load setting for improved control

Factory setting:

- Holiday temperature 17 °C
- Setback temperature 17 °C
- Comfort temperature 20 °C
- Comfort times: Mon–Fri 5 am–9 am / 4 pm–10 pm, Sat / Sun 6 am–10 pm
- Key lock disabled
- Automatic adjustment to summer / winter time enabled
- Valve and pump protection disabled
- Learning function disabled
- Display lighting (10 s)
- Heating load 0.1 kW
- 2-point control method
- External sensor
- 2 kOhm and max. floor temperature 42 °C (if configured as floor temperature controller)

HTRRUu with alre frame 'Berlin'

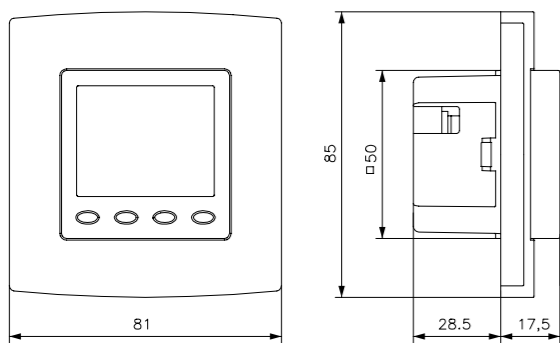

HF-8 / 4-K2

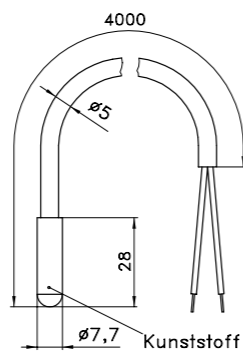

THF

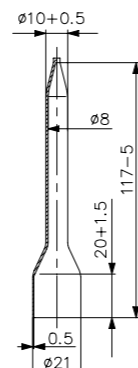

ADAPTATION OF ALRE FLUSH-MOUNTED CONTROLLERS – HTRRUU 210.021

MANUFACTURER	RANGE	COLOUR RAL 9010 (surface finish)	ADAPTATION in switch range (55 x 55) possible with...	'50 x 50' adaptation possible with... (insert frame from switch manufacturer required)
BERKER	S.1	polar white (matt)	HTRRUu 210.021#56	not required
BERKER	S.1	polar white (glossy)	HTRRUu 210.021#55	not required
BERKER	Arsys	polar white (glossy)		HTRRUu 210.021#07 + (1108 01 69)
BERKER	B.3	aluminium / polar white (matt)	HTRRUu 210.021#56	not required
BERKER	B.3	aluminium / polar white (glossy)	HTRRUu 210.021#55	not required
BERKER	B.7	glass / polar white (matt)	HTRRUu 210.021#56	not required
BERKER	B.7	glass / polar white (glossy)	HTRRUu 210.021#55	not required
BERKER	K.1	polar white (glossy)		HTRRUu 210.021#07 + (1108 71 09)
BUSCH-JAEGER	Reflex SI / SI Linear	alpine white (glossy)	HTRRUu 210.021#28	not required
BUSCH-JAEGER	Busch-balance SI	alpine white (glossy)	HTRRUu 210.021#55	not required
BUSCH-JAEGER	impuls	alpine white (glossy)		HTRRUu 210.021#07 + (1746 / 10-74)
BUSCH-JAEGER	solo / future / axcent etc.	studio white – see RAL 9016 below		
Elso	Joy	pure white (glossy)	HTRRUu 210.021#55	not required
Elso	Fashion / Riva / Scala	pure white (glossy)		HTRRUu 210.021#07 + 203084
GIRA	surface switch	pure white (glossy)		HTRRUu 210.021#07 + (0282 112)
GIRA (System 55)	Standard / E2	pure white (semi-gloss)	HTRRUu 210.021#56	not required
GIRA (System 55)	Standard / E2 / E3	pure white (glossy)	HTRRUu 210.021#55	not required
GIRA (System 55)	E22	pure white (glossy)	HTRRUu 210.021#55	not required
GIRA (System 55)	Event	pure white (semi-gloss) + opaque...	HTRRUu 210.021#56	not required
GIRA (System 55)	Event	pure white (glossy) + opaque...	HTRRUu 210.021#55	not required
GIRA (System 55)	Esprit	pure white (semi-gloss) + glass, aluminium...	HTRRUu 210.021#56	not required
GIRA (System 55)	Esprit	pure white (glossy) + glass, aluminium...	HTRRUu 210.021#55	not required
GIRA	S-Color	pure white (high-gloss)		HTRRUu 210.021#07 + (0282 40)
JUNG	CD 500 / CD plus	alpine white (glossy)**		HTRRUu 210.021#07 + (CD 590 Z WW)
JUNG	A 500 / AS 500 / A plus	alpine white (glossy)**	HTRRUu 210.021#55	not required
JUNG	LS 990	alpine white (glossy)**		HTRRUu 210.021#07 + (LS 961 Z WW)
JUNG	LS plus	alpine white (glossy)**		HTRRUu 210.021#07 + (LS 961 Z WW)
JUNG	A creation	alpine white (glossy)	HTRRUu 210.021#55	not required
JUNG	LS Design	alpine white (glossy)		HTRRUu 210.021#07 + (LS 961 Z WW)
JUNG	AS 550 / A flow	snow white matt	HTRRUu-210.021#56	not required
MERTEN (System M)	M-Smart, M-Plan, M-Pure	polar white (matt)	HTRRUu 210.021#56	not required
MERTEN (System M)	M-Smart, M-Plan, M-Creativ, M-Pure	polar white (glossy)	HTRRUu 210.021#55	not required
MERTEN (System Basis)	1-M / Atelier-M	polar white (glossy)	HTRRUu 210.021#55	not required
MERTEN (Surface System)	Artec / Antik	polar white (glossy)		HTRRUu 210.021#07 + (5160 99)
MERTEN	1-M / M-Smart / M-Plan / M-Pure / D-Life	active white – see RAL 9016 below		
PEHA	Standard	pure white (glossy)		HTRRUu 210.021#07 + (80.670.02 ZV)
PEHA	Dialog	pure white (glossy)		HTRRUu 210.021#07 + (95.670.02 ZV)
PEHA	Aura	pure white (matt) / glass		HTRRUu 210.021#07 + (20.670.02 ZV)
PEHA	Badora	pure white (glossy)		HTRRUu 210.021#07 + (11.670.02 ZV)

MANUFACTURER	RANGE	COLOUR RAL 9016 (surface finish)	ADAPTATION in switch range (55 x 55) possible with...	'50 x 50' adaptation possible with... (insert frame from switch manufacturer required)
BUSCH-JAEGER	solo / future / future linear	studio white (RAL 9016, glossy)		HTRRUu 210.021#27 + (1746 / 10-84)
BUSCH-JAEGER	axcent	studio white (RAL 9016, glossy)		HTRRUu 210.021#27 + (1746 / 10-84)
BUSCH-JAEGER	carat (glass, bronze, gold)	studio white (RAL 9016, glossy)		HTRRUu 210.021#27 + (1746 / 10-84)
BUSCH-JAEGER	alpha (nea / exclusive *)	studio white (RAL 9016, glossy)		HTRRUu 210.021#27 + (1746 / 10-24G)
MERTEN	M-Smart, M-Plan, M-Pure	active white (RAL 9016, glossy)	HTRRUu 210.021#59	not required
MERTEN	1-M / Atelier-M	active white (RAL 9016, glossy)	HTRRUu 210.021#59	not required
MERTEN	D-Life	lotus white (RAL 9016)		HTRRUu 210.021#27 + MEG4500-6035
PEHA	Standard	arctic		HTRRUu 210.021#27 + (D 80.670 ZV AW)

*) During assembly, you need to remove 4 plastic tabs located at the rear of the frame

** if necessary, the manufacturer JUNG will change the colour from RAL 9010 to RAL 9016

NOTE: Most light switches are designed in the colour 'similar to RAL 9010', although different switch manufacturers use different designations for this colour. Coloured, glass and aluminium frames are also combined with white jacks or plugs so that controllers with white covers can also be integrated into these frames. Check the precise application in each individual case. The frames have different surface qualities (matt/glossy). For design reasons, the cover of the controller should have the same quality as the frame. We accept no liability for slight variations in colour and surface finish or for accuracy of fit. When installing devices into multi frames, always assemble the temperature controllers at the lowermost position.

'50 x 50 controller': The housing covers of the 50 x 50 controllers are 50 x 50 mm in size. Using a 50 x 50 mm insert frame, they can be integrated into nearly all light switch ranges in accordance with DIN 49075. The 50 x 50 mm insert frames must be ordered from the light switch manufacturer or from a wholesaler. The order number of the insert frame corresponding to the switch range in question can be found in the column 'For adaptation of the use '50 x 50' HTRRUu.

'55 x 55 controller': The housing covers of the 55 x 55 controllers are 55 x 55 mm in size. Many light switch ranges have inner dimensions of 55 x 55 mm. Therefore, the 55 x 55 controllers can be installed directly in the light switch frame without the use of an insert frame. See the column 'Adaptation in switch range (55 x 55)' to determine whether the 55 x 55 controller fits in the given light switch range (HTRRUu 210.021#xx).

All information regarding switch manufacturers' product lines and item numbers was last updated in 12/2022 | No liability is assumed for the information provided. | TECHNICAL DATA subject to change.

FLOOR OR SURFACE TEMPERATURE CONTROLLER, ELECTRONIC, WITH REMOTE SENSOR (FOR FLOOR HEATING / WALL AND CEILING HEATING / TILED STOVE) HTRRB SURFACE-MOUNTED INSTALLATION – DESIGN BERLIN 2000

FLOOR OR SURFACE TEMPERATURE CONTROLLER, ELECTRONIC, WITH REMOTE SENSOR (FOR FLOOR HEATING / WALL AND CEILING HEATING / TILED STOVE) HTRRB SURFACE-MOUNTED INSTALLATION – DESIGN BERLIN 2000



TECHNICAL DATA	
Design:	Berlin 2000
Surface finish:	matt
Housing colour:	pure white, similar to RAL 9010
Housing material:	ABS plastic
Operating voltage:	230 V AC, 50 Hz
Ambient temperature:	0 to 30 °C
Storage temperature:	-20 to +70 °C
Permissible atmospheric humidity:	Max. 95% rel. humidity, non-condensing
Electrical connection:	screw-type terminals
Mounting / attachment:	surface- / wall-mounting (4-hole assembly on flush-mounted socket)
Protection rating:	IP30
Protection class:	II, if properly mounted
Safety and EMC:	according to DIN EN 60730
Max. switching current:	13 (2) A
Max. switching voltage:	230 V AC, 50 Hz
Min. switching voltage:	230 V AC, 50 Hz
Switching power:	3000 W
Switching element:	relay
Switching contact:	NO contact
Output signal:	230 V AC, 50 Hz
Sensor:	external, NTC
Sensor rupture and short-circuit protection:	heating is switched off
Control function:	heating
Hysteresis:	approx. 1 K
General features:	'heating' display; mechanical range limitation; 3000 W switching power for electric direct heating systems, natural stone heating; 'on/off' switch; external setting

APPLICATION
Temperature control (e.g., of electrical heating systems) for floor, fringe zone, bathroom, ceiling, tiled stove, marble and wall heating systems or tempering systems.
Note: The sensor line must be routed in a protective pipe. Parallel routing together with lines that carry alternating currents is not permitted.
Floor temperature controller with clock: HTRRBu-110.021
Floor temperature controller for distributor assembly: ITR 79 Series (plant engineering)

ACCESSORIES	ITEM NO.	FEATURES	EURO/PG
	G8000370	General features: Spare sensor for HTRRB-011.010 Ambient temperature: -5 to +70 °C Protection rating: IP65 Sensor: NTC Connecting cable: 4 m, PVC	26.50 / II
	G8000368	General features: Spare sensor for HTRRB-011.010 Ambient temperature: -5 to +70 °C Protection rating: IP65 Sensor: NTC Connecting cable: 6 m, PVC	29.50 / II
	G9031456	General features: Spare sensor for HTRRB-011.410 Ambient temperature: -50 to +150 °C Protection rating: IP65 Sensor: NTC Connecting cable: 4 m, silicone, H05SS-F <VDE> 2 x 0.75 mm²	56.60 / III
	G9990180	General features: Heat conduction paste 2 ml; R > 1 TΩ/cm, silicone-free Heat conductivity: > 0.7 W/mK Ambient temperature: -40 to +150 °C	7.70 / II
	C1809515	General features: protective sleeve for screed mounting (for sleeve sensor HF Ø 7.7, for example, HF-8/4-K2 or HF-8/6-K2), copper	45.00 / II

TYPE/IMAGE	ITEM NO.	FEATURES	CIRCUIT DIAGRAM	EURO/PG
	DA400000	General features: Floor temperature controller with remote sensor HF-8/4-K2 4 m, multi-digit display 1-6 Control range: 10 to 60 °C Note: The setting range can be adjusted to 10 to 40 °C (for example) using the mechanical range limitation as a replacement for the type HTRRB-010.310 .		142.60 / I
	DA400100	General features: Tiled stove surface temperature controller with remote sensor HF-5/4-K3 4 m; scale: degrees Celsius; threshold arrow Control range: 20-80 °C		202.40 / I

ILLUSTRATIONS

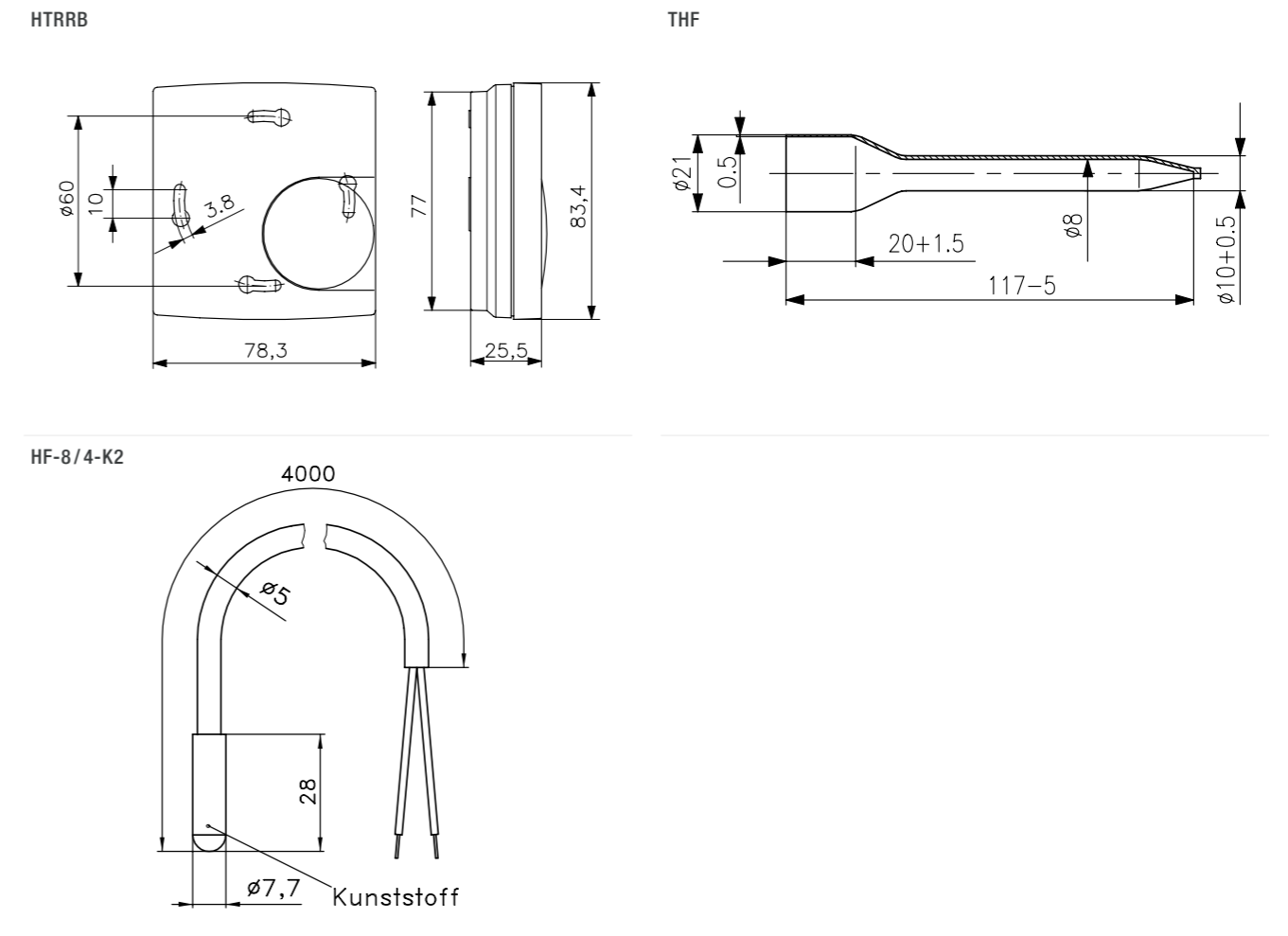

ELECTRONIC FLOOR OR SURFACE TEMPERATURE CONTROLLER WITH CLOCK AND REMOTE SENSOR (FOR FLOOR HEATING / WALL AND CEILING HEATING) HTRRBUSURFACE-MOUNTED INSTALLATION – DESIGN BERLIN 3000



TECHNICAL DATA

Design:	Berlin 3000
Surface finish:	matt
Housing colour:	pure white, similar to RAL 9010
Housing material:	ABS plastic
Operating voltage:	230 V AC, 50 Hz
Ambient temperature:	0 to 30 °C
Storage temperature:	-20 to +70 °C
Permissible atmospheric humidity:	Max. 95% rel. humidity, non-condensing
Electrical connection:	screw-type terminals 0.5–1.5 mm ²
Mounting / attachment:	surface / wall mounting or by means of an adapter plate on a flush-mounted socket
Protection rating:	IP30
Protection class:	II, if properly mounted according to DIN EN 60730
Safety and EMC:	heating (terminal 4) 13 (2) A, clock output (terminal 3) 100 mA
Max. switching current:	230 V AC, 50 Hz
Max. switching voltage:	230 V AC, 50 Hz
Min. switching voltage:	230 V AC, 50 Hz
Switching power:	terminal 4: 3000 W, terminal 3: 23 W
Switching element:	relay
Switching contact:	NO contact
Output signal:	switching (230 VAC, 50 Hz)
Sensor:	external, NTC
Control function:	heating
Control range:	10 to 42 °C
Hysteresis:	approx. 1 K
Display type:	symbol display
Output 'temperature reduction':	switching (230 VAC, 50 Hz), for pilot function

APPLICATION

Time-dependent temperature control (for example, of electrical heating systems) for floor, fringe zone, bathroom, ceiling, tiled stove, marble and wall heating systems or tempering systems.

It can be used as a master (pilot regulator) for the temperature reduction of other controllers. Controllers of the series FETR, RTBSU and RTBSB are suitable for use as slaves (satellite controllers).

Note: The sensor line must be routed in a protective pipe. Parallel routing together with lines that carry AC voltage is not permissible.



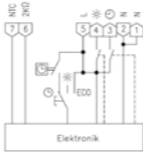

Programming procedures for every day, familiar from mechanical timers, by means of 'electronic tabs'. Shortest switching time 15 min.

General features: Pilot function; ECO function; ECO value adjustable; display 'ECO'; display 'On / Off'; display 'heating'; child-safe features; power reserve (approx. 4–7 days); learning function; valve protection; holiday setting; party setting; automatic adjustment to standard / daylight savings time; mechanical range limitation; reduction / comfort / automatic button; external setting; operation using direct-dial buttons; on / off button; information button; party function button; holiday setting button

TYPE/IMAGE	ITEM NO.	FEATURES	CIRCUIT DIAGRAM	EURO/PG
HTRRBu-110.021 	MA600400	With backlighting		302.90 / I

Accessories: terminal strips: VOOPL compatible valve actuators: ZB00A-010.1xx

ELECTRONIC FLOOR OR SURFACE TEMPERATURE CONTROLLER WITH CLOCK AND REMOTE SENSOR (FOR FLOOR HEATING / WALL AND CEILING HEATING) HTRRBUSURFACE-MOUNTED INSTALLATION – DESIGN BERLIN 3000

ACCESSORIES	ITEM NO.	FEATURES	EURO/PG
JZ-17 	MN990001	General features: Adapter plate for mounting devices on flush-mounted sockets (including fastening screws for mounting the controller on the adapter plate) Surface finish: matt Colour: pure white, similar to RAL 9010 Material: ABS plastic	8.20 / II
HF-8 / 4-K2 	G8000370	General features: Spare sensor for HTRRBu-110.021 Ambient temperature: -5 to +70 °C Protection rating: IP65 Sensor: NTC Connecting cable: 4 m, PVC	26.50 / II
HF-8 / 6-K2 	G8000368	General features: Spare sensor for HTRRBu-110.021 Ambient temperature: -5 to +70 °C Protection rating: IP65 Sensor: NTC Connecting cable: 6 m, PVC	29.50 / II
WP-01	G9990180	General features: Heat conduction paste 2 ml; R > 1 TΩ / cm, silicone-free Ambient temperature: -40 to +150 °C	7.70 / II
THF 	C1809515	General features: protective sleeve for screed mounting (for sleeve sensor HF Ø 7.7, for example, HF-8 / 4-K2 or HF-8 / 6-K2), copper	45.00 / II

ILLUSTRATIONS

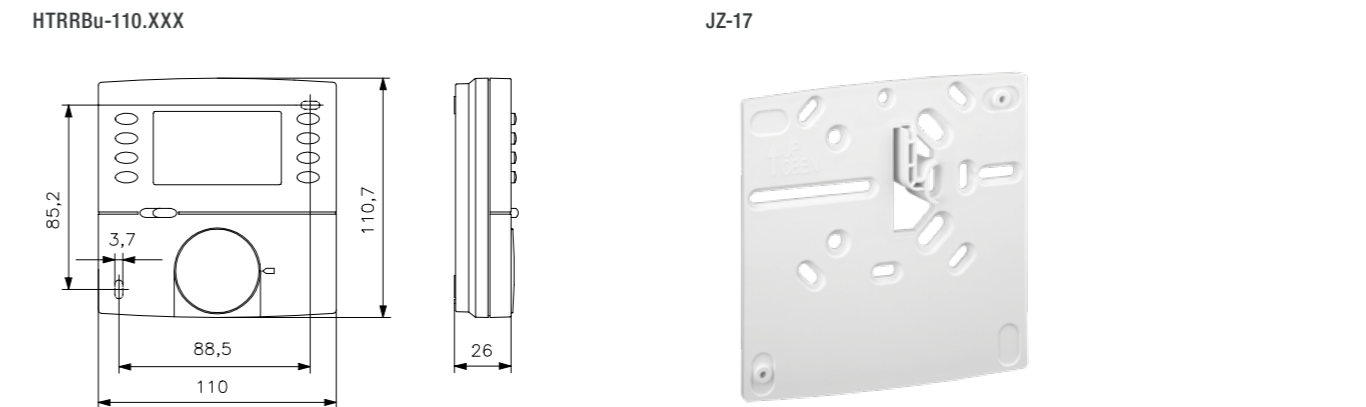

Factory setting:

- Setback temperature 1.7
- Continuous time display
- Programme display using switching segments enabled
- Child-safe features disabled
- Automatic adjustment to summer / winter time enabled
- Valve and pump protection disabled
- Learning function disabled
- Comfort times: Mon–Fri 5 am–9 am / 4 pm–10 pm, Sat / Sun 6 am–10 pm
- Sensor rupture and short-circuit safeguarding: In case of a sensor rupture or sensor short-circuit, the heating is activated with a power-on time of 30% to prevent cooling or frost damage in the room. Temperatures below -20 °C are also interpreted as sensor rupture, and the emergency function is triggered.

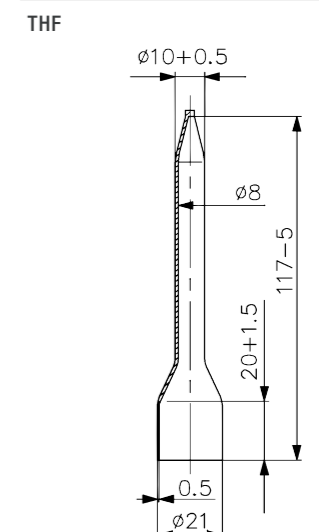
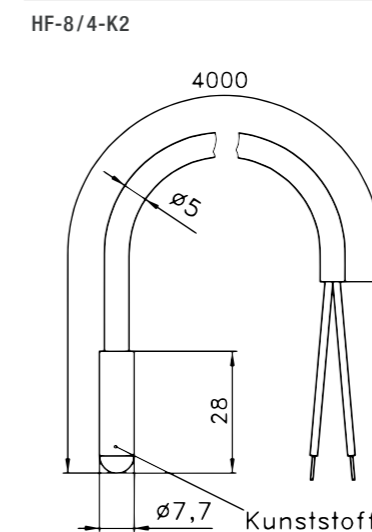

ELECTRONIC FLOOR TEMPERATURE CONTROLLER WITH REMOTE SENSOR (FOR FLOOR HEATING / WALL AND CEILING HEATING) FETR / RTERU

FLUSH-MOUNTED INSTALLATION – DESIGN BERLIN FLUSH-MOUNTED



TECHNICAL DATA	APPLICATION
<p>Design: Berlin flush-mounted</p> <p>Housing material: PC plastic (FETR) PA6 plastic (RTERU)</p> <p>Operating voltage: 230 V AC, 50 Hz</p> <p>Storage temperature: -20 to +70 °C</p> <p>Permissible atmospheric humidity: Max. 95% rel. humidity, non-condensing</p> <p>Electrical connection: screw-type terminals (FETR) pluggable screw terminals</p> <p>Mounting / attachment: In flush-mounted socket – with suitable cover set, can be adapted to fit virtually any switch range (deep flush-mounted socket recommended)</p> <p>Protection rating: IP30</p> <p>Protection class: II, if properly mounted</p> <p>Safety and EMC: according to DIN EN 60730</p> <p>Max. switching voltage: 230 V AC, 50 Hz</p> <p>Min. switching voltage: 230 V AC, 50 Hz</p> <p>Switching element: relay</p> <p>Switching contact: NO contact</p> <p>Output signal: switching (230 VAC, 50 Hz)</p> <p>Sensor: external or internal / external (monitors)</p> <p>Sensor type (external): HF-8 / 4-K2</p> <p>Sensor rupture and short-circuit protection: heating is switched off</p> <p>Sensor wire extendible up to: 50 m with min. 0.5 mm² double-insulated</p> <p>Control function: heating</p> <p>Hysteresis: < 1 K (FETR) 1.5 K (RTERU)</p> <p>General features: ECO function; 'reduction' display (FETR); 'heating' display</p> <p>Input 'temperature reduction': approx. 5 K (230 VAC, 50 Hz)</p>	<p>Temperature control (e.g., of electrical heating systems) for floor, fringe zone, bathroom, ceiling, tiled stove, marble and wall heating systems or tempering systems, direct floor heating systems.</p> <p>Reduction: With these flush-mounted controllers, the temperature can be reduced by 5 K. For this purpose, potential is applied to the clock input terminal by an external pilot controller or an external timer L1.</p> <p>Note: The sensor line must be routed in a protective pipe. Parallel routing together with lines that carry alternating currents is not admissible.</p> <p>The 55 x 55 mm variants visually fit perfectly without an insert frame in many switch ranges of 55 x 55 mm.</p> <p>Using an insert frame, the 50 x 50 mm variants fit in almost all switch ranges.</p> <p>See page for an overview of currently possible combinations and insert frames page 103.</p>

TYPE/IMAGE	ITEM NO.	FEATURES	CIRCUIT DIAGRAM	EURO/PG
	UN110100	<p>General features: floor temperature controller; mechanical range limitation; on/off switch; external setting; protective cap; contact hazard protection cover plate; Multi-digit display *–6</p> <p>Ambient temperature: 0 to 35 °C</p> <p>Max. switching current: 10 (1.5) A</p> <p>Switching power: 2300 W</p> <p>Control range: 10 to 50 °C</p> <p>Scope of delivery: controller, remote sensor 4 m</p> <p>Cover sets are offered in various designs (see the separate overview, 'alre flush-mounted range (cover sets)') and are not included in the delivery.</p> <p>Suitable set no: JZ-035.xxx, e.g.: 50 x 50 mm cover set, pure white, glossy: JZ-035.000 55 x 55 mm cover set, pure white, gloss: JZ-035.100</p>		102.10 / I
	UN110109	Similar to RTERU-010.715#00 but scope of delivery as follows: controller, 4 m remote sensor, alre frame 'Berlin' (neutral), 50 x 50 mm cover, pure white (similar to RAL 9010), glossy		128.80 / I

ELECTRONIC FLOOR TEMPERATURE CONTROLLER WITH REMOTE SENSOR (FOR FLOOR HEATING / WALL AND CEILING HEATING) FETR / RTERU

FLUSH-MOUNTED INSTALLATION – DESIGN BERLIN FLUSH-MOUNTED

TYPE/IMAGE	ITEM NO.	FEATURES	CIRCUIT DIAGRAM	EURO/PG
	UN030000	<p>General features: Floor temperature controllers; internal setting; multi-digit display 1–6</p> <p>Ambient temperature: 0 to 40 °C</p> <p>Max. switching current: 16 (2) A</p> <p>Switching power: 3680 W</p> <p>Control range: 10 to 60 °C</p> <p>Scope of delivery: controller, remote sensor 4 m, cover 50 x 50 mm, pure white (similar to RAL 9010), glossy</p>		210.80 / I
	UA030119	<p>General features: Floor temperature controller; mechanical range limitation; 'on/off' switch; external setting; protective cap; contact hazard protection cover plate; multi-digit display 1–5</p> <p>Ambient temperature: 0 to 40 °C</p> <p>Max. switching current: 16 (2) A</p> <p>Switching power: 3680 W</p> <p>Control range: 10 to 50 °C</p> <p>Scope of delivery: controller, remote sensor 4 m</p> <p>Cover sets are offered in various designs (see the separate overview, 'alre flush-mounted range (cover sets)') and are not included in the delivery.</p> <p>Suitable set no: JZ-005.xxx, e.g.: 50 x 50 mm cover set, pure white, glossy: JZ-005.000 55 x 55 mm cover set, pure white, glossy: JZ-005.100</p>		185.90 / I
	UN030109	Similar to FETR 101.715#00, but with scope of delivery: controller, remote sensor 4 m, alre frame 'Berlin' (neutral), 50 x 50 mm cover, pure white (similar to RAL 9010), glossy		206.90 / I
	UA030502	Similar to FETR 101.715#00, but with control range 10 to 42 °C (multi-digit display 1–4)		185.90 / I

ACCESSORIES	ITEM NO.	FEATURES	EURO/PG
	G8000370	<p>General features: Spare sensor for RTERU/FETR 101.7xx</p> <p>Ambient temperature: -5 to +70 °C</p> <p>Protection rating: IP65</p> <p>Sensor: NTC</p> <p>Connecting cable: 4 m, PVC</p>	26.50 / II
	G8000368	<p>General features: Spare sensor for RTERU/FETR 101.7xx</p> <p>Ambient temperature: -5 to +70 °C</p> <p>Protection rating: IP65</p> <p>Sensor: NTC</p> <p>Connecting cable: 6 m, PVC</p>	29.50 / II
	G9990180	<p>General features: Heat conduction paste 2 ml; R > 1 TQ/cm, silicone-free</p> <p>Ambient temperature: -40 to +150 °C</p>	7.70 / II
	C1809515	<p>General features: protective sleeve for screed mounting (for sleeve sensor HF Ø 7.7, for example, HF-8 / 4-K2 or HF-8 / 6-K2), copper</p>	45.00 / II

ELECTRONIC FLOOR TEMPERATURE CONTROLLER WITH REMOTE SENSOR (FOR FLOOR HEATING / WALL AND CEILING HEATING) FETR / RTERU

FLUSH-MOUNTED INSTALLATION – DESIGN BERLIN FLUSH-MOUNTED

TYPE/IMAGE	ITEM NO.	FEATURES	CIRCUIT DIAGRAM	EURO/PG
	VV000025	General features: alre frame 'Berlin' (neutral) for all flush-mounted controllers with 50 x 50 mm cover Design: Berlin Surface finish: glossy Colour: Pure white, similar to RAL 9010 Material: PC plastic		4.80 / I
JZ-090.910	VV000010	Similar to JZ-090.900 but with pearl white colour similar to RAL 1013		4.80 / I
JZ-090.100	VV000048	Similar to JZ-090.900, but for all flush-mounted controllers in combination with 55 x 55 mm cover		4.80 / I

ALRE FLUSH-MOUNTED RANGE (COVER SETS)

ALL BASIC TYPES AND SUITABLE **50 X 50 MM** COVER SETS / B-J REFLEX SI / SI LINEAR

BASIC TYPE	50 x 50 mm cover set PURE WHITE (RAL 9010) GLOSSY (JZ-xxx.000)		50 x 50 mm cover set PURE WHITE (RAL 9010) MATT (JZ-xxx.001)		50 x 50 mm cover set PEARL WHITE (RAL 1013) GLOSSY (JZ-xxx.010)		EURO / PG	
	Cover set	Item no.	Cover set	Item no.	Cover set	Item no.		
FETR 101.715#00	JZ-005.000	UN990003	JZ-005.001	UN990006	JZ-005.010	UN990009	16.80 / I	
FETR 101.716#00	JZ-009.000	UN990004	JZ-009.001	UN990007	JZ-009.010	UN990010	16.80 / I	
RTERU 010.715#00	JZ-035.000	UN990169	JZ-035.001	UN990193	JZ-035.010	UN990177	9.50 / I	
BASIC TYPE	50 x 50 mm cover set TRAFFIC/STUDIO WHITE (RAL 9016) GLOSSY (JZ-xxx.020)		50 x 50 mm cover set TRAFFIC WHITE (RAL 9016) MATT (JZ-xxx.021)		EURO / PG	BUSCH-JAEGER cover set REFLEX SI/SI LINEAR PURE WHITE (RAL 9010) GLOSSY (JZ-xxx.200 / BJ)		EURO / PG
	Cover set	Item no.	Cover set	Item no.		Cover set	Item no.	
FETR 101.715#00	JZ-005.020	UN990075	JZ-005.021	UN990104	16.80 / I	–	–	
FETR 101.716#00	JZ-009.020	UN990076	JZ-009.021	UN990106	16.80 / I	–	–	
RTERU 010.715#00	JZ-035.020	UN990185	JZ-035.021	UN990201	9.50 / I	JZ-035.200 / BJ	G9990499	10.00 / I

In flush-mounted socket, it can be adapted to fit virtually any switch range.

ALL BASIC TYPES AND SUITABLE COVER SETS **55 X 55 MM**

BASIC TYPE	55 x 55 mm cover set PURE WHITE (RAL 9010) GLOSSY (JZ-xxx.100)		55 x 55 mm cover set PURE WHITE (RAL 9010) MATT (JZ-xxx.101)		55 x 55 mm cover set PEARL WHITE (RAL 1013) GLOSSY (JZ-xxx.110)		EURO / PG
	Cover set	Item no.	Cover set	Item no.	Cover set	Item no.	
FETR 101.715#00	JZ-005.100	UN990012	JZ-005.101	UN990015	JZ-005.110	UN990018	18.60 / I
FETR 101.716#00	JZ-009.100	UN990013	JZ-009.101	UN990016	JZ-009.110	UN990019	18.60 / I
RTERU 010.715#00	JZ-035.100	UN990173	JZ-035.101	UN990197	JZ-035.110	UN990181	10.00 / I
BASIC TYPE	55 x 55 mm cover set TRAFFIC/ STUDIO WHITE (RAL 9016) GLOSSY (JZ-xxx.120)		EURO / PG	SPECIAL COLOURS AS WELL AS THE COLOURS ANTHRACITE AND ALUMINIUM ARE AVAILABLE UPON REQUEST.			
	Cover set	Item no.		Cover set	Item no.	Cover set	Item no.
FETR 101.715#00	JZ-005.120	UN990091	18.60 / I				
FETR 101.716#00	JZ-009.120	UN990092	18.60 / I				
RTERU 010.715#00	JZ-035.120	UN990189	10.00 / I				

ALL BASIC TYPES AND SUITABLE COVER SETS **70 X 70 MM**

BASIC TYPE	70 x 70 mm cover set PURE WHITE (RAL 9010) GLOSSY (JZ-xxx.400)		70 x 70 mm cover set PEARL WHITE (RAL 1013) GLOSSY (JZ-xxx.410)		EURO / PG	70 x 70 mm cover set TRAFFIC/ STUDIO WHITE (RAL 9016) GLOSSY (JZ-xxx.420)		EURO / PG
	Cover set	Item no.	Cover set	Item no.		Cover set	Item no.	
RTERU 010.715#00	JZ-035.400	UN990143	JZ-035.401	UN990147	9.70 / I	JZ-035.420	UN990151	10.00 / I

ADAPTATION OF ALRE FLUSH-MOUNTED CONTROLLERS

MANUFACTURER	RANGE	COLOUR RAL 9010 (surface finish)	ADAPTATION possible with '55 x 55' or '70 x 70' cover set (without insert frame)	'50 X 50' adaptation possible with... (insert frame from manufacturer required)
BERKER	S.1	polar white (matt)	x	1109 19 19
BERKER	S.1	polar white (glossy)	x	1109 90 89
BERKER	Arsys	polar white (glossy)		1108 01 69
BERKER	B.3	aluminium / polar white (matt)	x	1109 19 19
BERKER	B.3	aluminium / polar white (glossy)	x	1109 90 89
BERKER	B.7	glass / polar white (matt)	x	1109 19 19
BERKER	B.7	glass / polar white (glossy)	x	1109 90 89
BERKER	Q.1 / Q.3	polar white (velvet)		1109 60 79
BERKER	K.1	polar white (glossy)		1108 71 09
BUSCH-JAEGER	Reflex SI / SI Linear	alpine white (glossy)		1746-214-101
BUSCH-JAEGER	Busch-balance SI	alpine white (glossy)	x	1746-914-101
BUSCH-JAEGER	impuls	alpine white (glossy)		1746 / 10-74
BUSCH-JAEGER	solo / future / axcent etc.	studio white – see RAL 9016 below		
Els0	Joy	pure white (glossy)	x	363084
Els0	Fashion / Riva / Scala	pure white (glossy)		203084
GIRA	surface switch	pure white (glossy)	x	0282 112
GIRA (System 55)	Standard / E2	pure white (semi-gloss)	x	0282 27
GIRA (System 55)	Standard / E2	pure white (glossy)	x	0282 03
GIRA (System 55)	E22	pure white (glossy)	x	0282 03
GIRA (System 55)	Event	pure white (semi-gloss) + opaque...	x	0282 27
GIRA (System 55)	Event	pure white (glossy) + opaque...	x	0282 03
GIRA (System 55)	Esprit	pure white (semi-gloss) + glass, aluminium...	x	0282 27
GIRA (System 55)	Esprit	pure white (glossy) + glass, aluminium...	x	0282 03
GIRA	S-Color	pure white (high-gloss)		0282 40
JUNG	CD 500 / CD plus	alpine white (glossy)		CD 590 Z WW
JUNG	A 500 / AS 500 / A plus	alpine white (glossy)	x	A 590 Z WW
JUNG	LS 990	alpine white (glossy)	x	LS 961 Z WW
JUNG	LS plus	alpine white (glass)	x	LS 961 Z WW
JUNG	A creation	alpine white (glossy)	x	A 590 Z WW
JUNG	LS Design	alpine white (glossy)	x	LS 961 Z WW
MERTEN (System M)	M-Smart, M-Plan, M-Pure	polar white (matt)	x	5181 19
MERTEN (System M)	M-Smart, M-Plan, M-Creativ, M-Pure	polar white (glossy)	x	5185 19
MERTEN (System Basis)	1-M / Atelier-M	polar white (glossy)	x	5185 19
MERTEN (Surface System)	Artec / Antik	polar white (glossy)		5160 99
MERTEN	1-M / M-Smart / M-Plan / M-Pure / D-Life	active white – see RAL 9016 below or product finder		
PEHA	Standard	pure white (glossy)		80.670.02 ZV
PEHA	Dialog	pure white (glossy)		95.670.02 ZV
PEHA	Aura	pure white (matt) / glass		20.670.02 ZV
PEHA	Badora	pure white (glossy)		11.670.02 ZV
MANUFACTURER	RANGE	COLOUR RAL 9016 (surface finish)	ADAPTATION in switch range ('55 x 55' or '70 x 70') possible with...	'50 x 50' adaptation possible with... (insert frame from switch manufacturer required)
BUSCH-JAEGER	solo / future / future linear	studio white (RAL 9016, glossy)		1746 / 10-84
BUSCH-JAEGER	future linear	studio white (RAL 9016 matt)		1746 / 10-884
BUSCH-JAEGER	impuls	studio white (RAL 9016 matt)		1746 / 10-774
BUSCH-JAEGER	axcent	studio white (RAL 9016, glossy)		1746 / 10-84
BUSCH-JAEGER	carat (glass, bronze, gold)	studio white (RAL 9016, glossy)		1746 / 10-84
BUSCH-JAEGER	alpha (nea / exclusive *)	studio white (RAL 9016, glossy)		1746 / 10-24G
BUSCH-JAEGER	alpha (nea / exclusive *)	studio white (RAL 9016 matt)		1746 / 10-24
MERTEN	M-Smart, M-Plan, M-Pure	active white (RAL 9016, glossy)	x	5185 25
MERTEN	1-M / Atelier-M	active white (RAL 9016, glossy)	x	5185 25
MERTEN	D-Life	lotus white (RAL 9016)	x	MEG4500-6035
PEHA	Standard	arctic		D 80.670 ZV AW

*) During assembly, you need to remove 4 plastic tabs located at the rear of the frame

NOTE: Most light switches are designed in the colour 'similar to RAL 9010', although different switch manufacturers use different designations for this colour. Coloured, glass and aluminium frames are also combined with white jacks or plugs so that controllers with white covers can also be integrated into these frames. Check the precise application in each individual case. The frames have different surface qualities (matt/glossy). For design reasons, the cover of the controller should have the same quality as the frame. We accept no liability for slight variations in colour and surface finish or for accuracy of fit. When installing devices into multi frames, always assemble the temperature controllers at the lowermost position.

'50 x 50 controller': The housing covers of the 50 x 50 controllers are 50 x 50 mm in size. Using a 50 x 50 mm insert frame, they can be integrated into nearly all light switch ranges in accordance with DIN 49075. The 50 x 50 mm insert frames must be ordered from the light switch manufacturer or from a wholesaler. The order number of the insert frame corresponding to the switch range in question can be found in the column 'Only for adaptation with '50 x 50' cover set'.

'55 x 55 controller': The housing covers of the 55 x 55 controllers are 55 x 55 mm in size. Many light switch ranges have inner dimensions of 55 x 55 mm. Therefore, the 55 x 55 controllers can be installed directly in the light switch frame without the use of an insert frame. See the column 'Adaptation with '55 x 55' cover set' to determine whether the 55 x 55 controller fits in the given light switch model (x).

All information regarding switch manufacturers' product lines and item numbers was last updated in 12/2022 | No liability is assumed for the information provided. | Technical data subject to change.

Prices valid from 01.01.2026 – 31.12.2026, prices may be subject to change | V1

PRODUCT FINDER ALRE COVER SETS FOR SWITCH RANGES FROM BERKER

INTEGRATION EXAMPLES

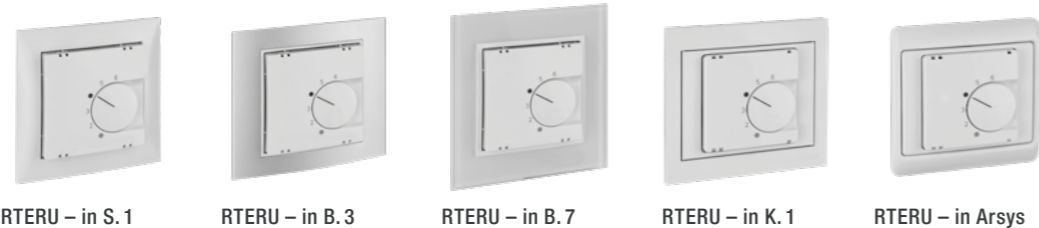

TYPE ALRE	BERKER RANGE	COLOUR (RAL)/ SURFACE FINISH	ALRE COVER SET	COVER SET ITEM NO.	INSERT FRAME 50X50*	EURO/ PG
 Standard	S.1/B.3/B.7	polar white (RAL 9010) glossy	JZ-035.100 (55 x 55, glossy)	UN990173	not required	10.00/I
	S.1/B.3/B.7	polar white (RAL 9010) matt	JZ-035.101 (55 x 55, matt)	UN990197	not required	10.00/I
	Arslys	polar white (RAL 9010) glossy	JZ-035.000 (50 x 50, glossy)	UN990169	1108 01 69	9.50/I
	Q.1/Q.3	polar white (RAL 9010) velvet	JZ-035.001 (50 x 50, matt)	UN990193	1109 60 79	9.50/I
	K.1	polar white (RAL 9010) glossy	JZ-035.110 (50 x 50, glossy)	UN990169	1108 71 09	9.50/I
	S.1	white (RAL 1013) glossy	JZ-035.110 (55 x 55, glossy)	UN990181	not required	10.00/I
	Arslys	white (RAL 1013) glossy	JZ-035.010 (50 x 50, glossy)	UN990177	1108 01 02	9.50/I

PRODUCT FINDER ALRE COVER SETS FOR SWITCH RANGES FROM BUSCH-JAEGER

INTEGRATION EXAMPLES

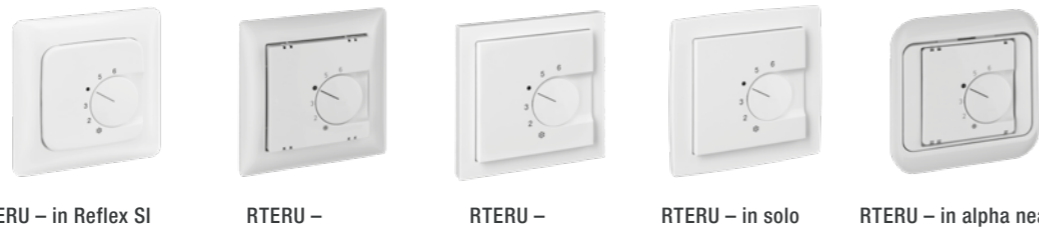

TYPE ALRE	BUSCH-JAEGER RANGE	COLOUR (RAL)/ SURFACE FINISH	ALRE COVER SET	COVER SET ITEM NO.	INSERT FRAME 50X50*	EURO/ PG
 Standard	Reflex SI/SI Linear	alpine white (RAL 9010) glossy	JZ-035.200 / BJ	G9990499	1746-214-101	10.00/I
	Busch-balance SI	alpine white (RAL 9010) glossy	JZ-035.100 (55 x 55, glossy)	UN990173	not required	10.00/I
	impuls	alpine white (RAL 9010) glossy	JZ-035.000 (50 x 50, glossy)	UN990169	1746 / 10-74	9.50/I
	future linear / solo / axcent / carat	studio white (RAL 9016) glossy	JZ-035.020 (50 x 50, glossy)	UN990185	1746 / 10-84	9.50/I
	future linear	studio white (RAL 9016) matt	JZ-035.021 (50 x 50, matt)	UN990201	1746 / 10-884	9.50/I
	alpha nea	studio white (RAL 9016) glossy	JZ-035.020 (50 x 50, glossy)	UN990185	1746 / 10-24G	9.50/I
	alpha nea	studio white (RAL 9016) matt	JZ-035.021 (50 x 50, matt)	UN990201	1746 / 10-24	9.50/I
	Duro 2000 SI/SI Linear	white (RAL 1013) glossy	JZ-035.010 (50 x 50, glossy)	UN990177	1746-212-101	9.50/I
	future linear / solo / carat	ivory white (RAL 1013) glossy	JZ-035.010 (50 x 50, glossy)	UN990177	1746 / 10-82	9.50/I
	alpha nea	ivory white (RAL 1013) glossy	JZ-035.010 (50 x 50, glossy)	UN990177	1746 / 10-22G	9.50/I
	impuls	ivory white (RAL 1013) glossy	JZ-035.010 (50 x 50, glossy)	UN990177	1746 / 10-72	9.50/I

PRODUCT FINDER ALRE COVER SETS FOR SWITCH RANGES FROM ELSO

INTEGRATION EXAMPLES

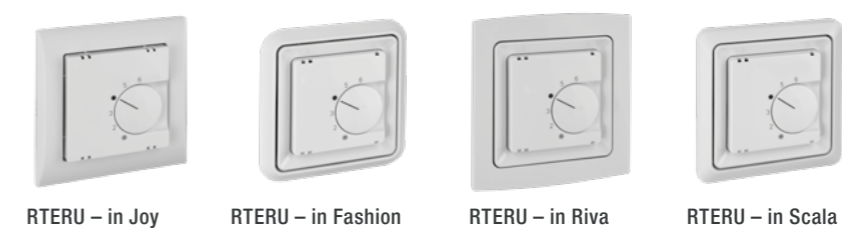

TYPE ALRE	ELSO RANGE	COLOUR (RAL)/ SURFACE FINISH	ALRE COVER SET	COVER SET ITEM NO.	INSERT FRAME 50X50*	EURO/ PG
 Standard	Joy	pure white (RAL 9010) glossy	JZ-035.100 (55 x 55, glossy)	UN990173	not required	10.00/I
	Joy	pearl white (RAL 1013) glossy	JZ-035.110 (55 x 55, glossy)	UN990181	not required	10.00/I
	Fashion / Riva / Scala	pure white (RAL 9010) glossy	JZ-035.000 (50 x 50, glossy)	UN990169	203084	9.50/I
	Fashion / Riva / Scala	pearl white (RAL 1013) glossy	JZ-035.010 (50 x 50, glossy)	UN990177	203080	9.50/I

PRODUCT FINDER ALRE COVER SETS FOR SWITCH RANGES FROM GIRA

INTEGRATION EXAMPLES



TYPE ALRE	GIRA RANGE	COLOUR (RAL)/ SURFACE FINISH	ALRE COVER SET	COVER SET ITEM NO.	INSERT FRAME 50X50*	EURO/ PG
 Standard	Standard 55 / E2 / E22 / Event / Esprit	pure white (RAL 9010) glossy	JZ-035.100 (55 x 55, glossy)	UN990173	not required	10.00/I
	Standard 55 / E2 / E22 / Event / Esprit	pure white (RAL 9010) matt	JZ-035.101 (55 x 55, matt)	UN990197	not required	10.00/I
	Surface switch NEW	pure white (RAL 9010) glossy	JZ-035.400 (70 x 70, glossy)	UN990143	not required	10.00/I
	Standard 55 / Event / Esprit / ClassiX	cream white (RAL 1013) glossy	JZ-035.110 (55 x 55, glossy)	UN990181	not required	10.00/I

PRODUCT FINDER ALRE COVER SETS

FOR SWITCH RANGES FROM JUNG

INTEGRATION EXAMPLES



TYPE ALRE	JUNG RANGE	COLOUR (RAL)/ SURFACE FINISH	ALRE COVER SET	COVER SET ITEM NO.	INSERT FRAME 50X50*	EURO/ PG
RTERU-010.715#00	AS 500 / A 500 / A 550 / A creation / A plus / A flow	alpine white (RAL 9010) glossy	JZ-035.100 (55 x 55, glossy)	UN990173	not required	10.00/1
	CD 500 / CD plus	alpine white (RAL 9010) glossy	JZ-035.000 (50 x 50, glossy)	UN990169	CD 590 Z WW	9.50/1
	LS 990 / LS design / LS plus	alpine white (RAL 9010) glossy	JZ-035.400 (70 x 70, glossy)	UN990143	not required	10.00/1
	AS 500	white (RAL 1013) glossy	JZ-035.110 (55 x 55, glossy)	UN990181	not required	10.00/1
Standard	CD 500 / CD plus	white (RAL 1013) glossy	JZ-035.010 (50 x 50, glossy)	UN990177	590 Z	9.50/1
	LS 990 / LS design / LS plus	white (RAL 1013) glossy	JZ-035.410 (70 x 70, glossy)	UN990147	not required	10.00/1

PRODUCT FINDER ALRE COVER SETS

FOR SWITCH RANGES FROM MERTEN

INTEGRATION EXAMPLES



TYPE ALRE	MERTEN RANGE	COLOUR (RAL)/ SURFACE FINISH	ALRE COVER SET	COVER SET ITEM NO.	INSERT FRAME 50X50*	EURO/ PG
RTERU-010.715#00	1-M, Atelier-M / M-Smart, M-Pure, M-Plan, M-Creativ	polar white (RAL 9010) glossy	JZ-035.100 (55 x 55, glossy)	UN990173	not required	10.00/1
	1-M, Atelier-M / M-Smart, M-Pure, M-Plan, M-Creativ	polar white (RAL 9010) matt	JZ-035.101 (55 x 55, matt)	UN990197	not required	10.00/1
Standard	1-M, Atelier-M / M-Smart, M-Pure, M-Plan, M-Creativ	active white (RAL 9016) glossy	JZ-035.120 (55 x 55, glossy)	UN990189	not required	10.00/1
	D-Life	lotus white (RAL 9016) glossy	JZ-035.420 (70 x 70, glossy)	UN990151	not required	10.00/1
	System design: Artec, Antik	polar white (RAL 9010) glossy	JZ-035.000 (50 x 50, glossy)	UN990169	5160 99	9.50/1
	1-M, Atelier-M / M-Smart, M-Pure, M-Plan, M-Creativ	white (RAL 1013) glossy	JZ-035.110 (55 x 55, glossy)	UN990181	not required	10.00/1
	System design: Artec, Antik	white (RAL 1013) glossy	JZ-035.010 (50 x 50, glossy)	UN990177	5160 94	9.50/1

ELECTRONIC FLOOR TEMPERATURE CONTROLLER WITH REMOTE SENSOR (FOR FLOOR HEATING / WALL AND CEILING HEATING) FETR / RTERU

FLUSH-MOUNTED INSTALLATION – DESIGN BERLIN FLUSH-MOUNTED

ILLUSTRATIONS

HF-8/4-K2

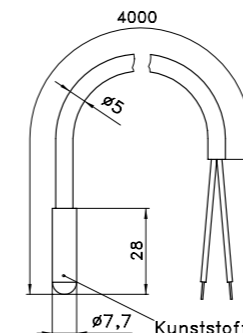

THF

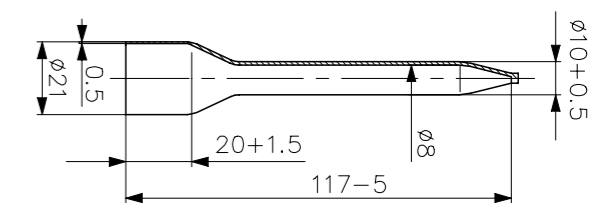

RTERU with alre frame 'Berlin' (#21 types)

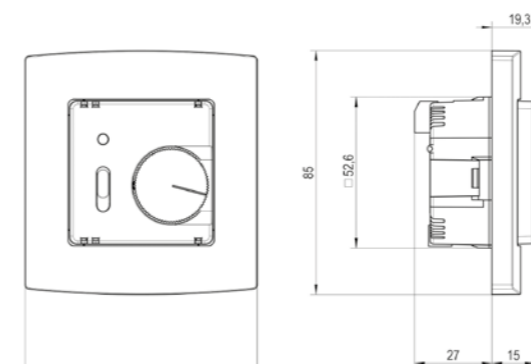

with 50 x 50 mm insert frame

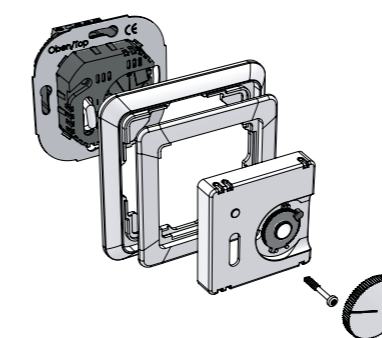

Internal scale RTERU for temperature control without cover

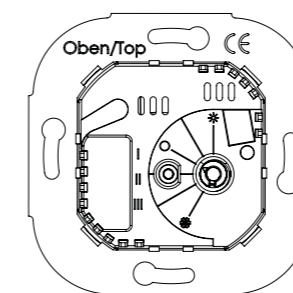

alre frame 'Berlin' (#21 types)

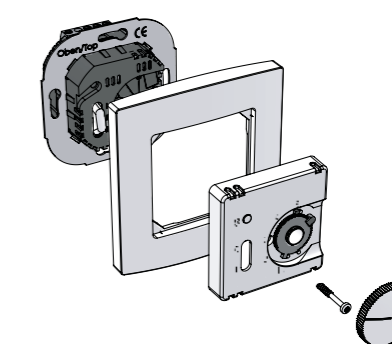

without 55 x 55 mm insert frame

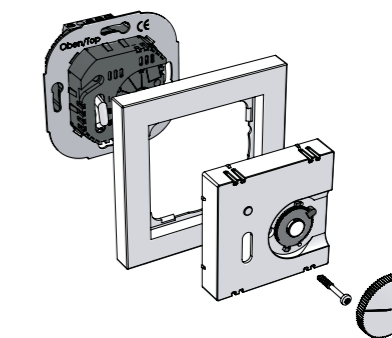

Contact hazard protection cap with scale (for FETR 101.700 with internal setting – similar to illustration)

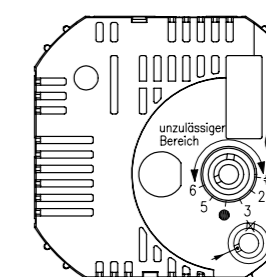

ACTUATOR 'STELLA' 230 V NC FOR AUTOMATIC HYDRAULIC COMPARISON

TECHNICAL DATA

Operating voltage:	230 V~, 50 Hz
Max. power consumption:	30 W
Max. starting current:	approx. 0.13 A
Housing colour:	grey-orange
Housing material:	PA6 plastic
Ambient temperature:	0 to 50 °C
Storage temperature:	-25 to +60 °C
Permissible atmospheric humidity:	Max. 95% rel. humidity, non-condensing
Mounting / attachment:	M 30 x 1.5
Protection rating:	IP54
Protection class:	II
Safety and EMC:	according to DIN EN 60730
Average power consumption:	approx. 1.7 W
Opening / closing time:	approx. 3 min
Nominal stroke:	3.5 mm
Function type:	normally closed
Nominal closing force:	110 N
Connecting cable:	1 m / 2 x 0.34 mm ²

APPLICATION

'Stella' – the intelligent autonomous 230 VAC NC electrothermal actuator for automatic adaptive hydraulic balancing of heating manifolds' heating circuits in surface heating and surface cooling systems.

Sensors on the supply and return lines measure temperature differences, and an algorithm continuously calculates the necessary temperature spread and the appropriate valve position.

Normally closed and features a folding lever for easily unscrewing the thermostat valve or opening it manually when it is disconnected from the mains. Features integrated inflow temperature limitation.

Can be combined with all standard temperature controllers and terminal strips. Can be combined with standard two-point room temperature controllers (electromechanical, electronic, PWM). When using devices with a Triac switching element, the Triac must have a voltage resistance (V DRM) of at least 800 V.



TYPE/IMAGE	ITEM NO.	FEATURES	CIRCUIT DIAGRAM	EURO/PG
ZB00A-010.185 	G8990010	Actuator for automatic hydraulic balancing		86.40 / I
SET 31 	VV000046	Set for performing fully automatic hydraulic balancing consisting of 5 surface-mounted room thermostats, 1 terminal strip and 6 actuators.		818.70 / I
SET 32 	VV000047	Set for performing fully automatic hydraulic balancing consisting of 5 flush-mounted room thermostats, 1 terminal strip and 6 actuators.		913.90 / I

ILLUSTRATIONS



BRIEF DESCRIPTION

- Combinable with the commercial 2-point room temperature controllers (electromechanical, electronic, PWM), except devices with triac switching element
- for heating and cooling systems
- Features a folding lever for easily unscrewing the thermostat valve or opening it manually when it is disconnected from the mains
- Temperature sensors suited for surface heating pipes made of plastic, metal or combinations thereof with an external diameter of 12 to 20 mm
- measures a heating circuit's outflow temperature
- The range of setpoint temperatures Stella calculates is variable and dependent on user behaviour and the system's environment
- The valve can be adjusted to any desired position between OPEN and CLOSED and set to remain in that position.
- An expansion element and a stroke measuring system are needed to position the valve stroke.

ELECTRO-THERMAL VALVE ACTUATORS FOR HEATING, VENTILATION AND AIR CONDITIONING TECHNOLOGY

TECHNICAL DATA

Housing colour:	pure white, similar to RAL 9010
Housing material:	PC plastic, GF (20%)
Ambient temperature:	0 to 50 °C
Storage temperature:	-20 to +70 °C
Permissible atmospheric humidity:	Max. 95% rel. humidity, non-condensing
Mounting / attachment:	M 30 x 1.5
Protection rating:	IP42
Protection class:	II
Safety and EMC:	according to DIN EN 60730
Average power consumption:	approx. 3 W
Opening / closing time:	approx. 4 min
Nominal stroke:	3 mm
Function type:	normally closed
Nominal closing force:	90 N
Connecting cable:	0.8 m / 2 x 0.5 mm ²
Valve position indicator:	2X (at the top and the side)

APPLICATION

Extremely compact design: can be fitted quickly and comfortably thanks to the slim shape in the area around the fastening nut.

Can be fitted in any position: lateral drainage holes carry off any leakage water that from the valve plunger into the open, thus avoiding damage to the drive.

Additional valve monitoring: two additional viewing windows at the side allow users to visually check the respective valve position with ease; this does not work when mounted in a suspended manner.



TYPE/IMAGE	ITEM NO.	FEATURES	EURO/PG
ZB00A-010.100 	H9100010	Operating voltage: 230 V~, 50 Hz Max. power consumption: 70 W Max. starting current: approx. 0.3 A	33.80 / I
ZB00A-040.100 	H9100000	Operating voltage: 24 VDC or 24 VAC Max. power consumption: 12 W Max. starting current: approx. 0.5 A	33.80 / I

Thanks to their M 30 x 1.5 fastening and their characteristics (normally closed), the actuators are suitable for the following valve and distributor makes: Beulco, Empur, Heimeier, Kamo, Oventrop, Purmo, SBK, SKV, Strawa, Taconova, Watts

BRIEF DESCRIPTION:

The drive features a compact, space-saving design. The device can be mounted easily thanks to the narrowed shape, especially in the fastening area of the nut. The fastening cable is not located near the fastening nut. This reduces the probability of contact with equipment carrying hot water. Since the fastening nut allows continuous screwing onto the thread, by unscrewing the nut by two or three turns, it is possible to open the valve in an electrically de-energised state – something that cannot be done with bayonet couplings and impulse couplings. Discharged water is dissipated via a draining system. Gaskets are not required thanks to the special design.

THE DUAL POSITION DISPLAY OFFERS THE FOLLOWING ADVANTAGES:

The upper display provides the option of a visual or, in conditions of bad visibility, tactile function test of the drive. The lower viewing windows allow an additional check to determine whether the valve to be actuated follows the lifting movement of the drive. At the beginning of the heating period, it can happen off and on that the valve plungers get "stuck". Therefore, with the additional display, it is possible to determine whether the cause lies with the actuator or with the valve in the event the valve does not open. However, that is not possible when mounted in a suspended manner.

ILLUSTRATIONS

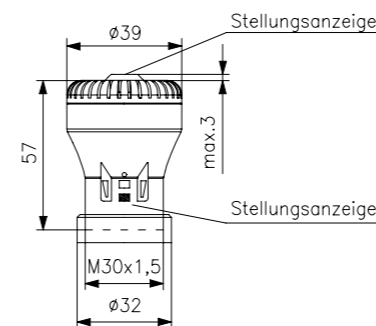

VALVE ACTUATOR WITH EXTENDED PUSH ROD



TERMINAL STRIP FOR HEATING MANIFOLD FOR 6 OR 8 ROOM THERMOSTATS

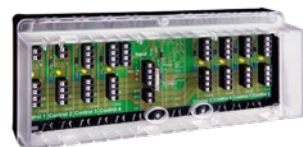



TECHNICAL DATA

Surface finish:	Upper part glossy, lower part matt
Housing colour:	Upper part transparent, lower part anthracite grey, similar to RAL 7016
Housing material:	PC plastic
Operating voltage:	230 VAC/50 Hz
Ambient temperature:	-10 to +50 °C
Storage temperature:	-20 to +70 °C
Permissible atmospheric humidity:	Max. 95% rel. humidity, non-condensing
Electrical connection:	spring terminals 0.75 mm ² -1.5 mm ² for rigid cables 0.5 mm ² -1 mm ² for flexible cables
Protection rating:	IP20
Mounting / attachment:	convenient and simple installation in the heating manifold via hat rails (standard rail or supporting rail EN 60715) or magnetic bases Surface / wall mounting with 4 fastening screws included in delivery or using optional JZ-32 magnetic fastening set
Protection class:	II, if properly mounted
Control function:	heating or cooling
General features:	Ready for operation display (mains voltage), active channels display, integrated strain relief, labelling fields

APPLICATION

Terminal strip for heating controller with or without ECO function, also for heating / cooling controller with integrated heating / cooling switch. Depending on the controller used, actuators can be connected in the NC (normally closed) or NO (normally open) mode of operation.

Can be set up with master-slave control when using a clock regulator or an external timer.

TYPE/IMAGE	ITEM NO.	FEATURES	EURO/PG
V00PL-216.176 	DA480510	General features: Terminal strip in housing for wiring up to 6 room thermostats and up to 12 actuators; (channel 1-2: 1 actuator / channel 3: 4 actuators / channel 4-6: 2 actuators), device fuse T3 15 A/250 V, installation dimensions Ø 5 x 20 mm (also secures the circuits of the connected controllers and valve gears)	86.50 / I
V00PL-318.178 	DA480520	General features: Terminal strip in housing for wiring up to 8 room thermostats and up to 16 actuators; (channel 1-2: 1 actuator / channel 3, 5-8: 2 actuators / channel 4: 4 actuators), device fuse T3 15 A/250 V, installation dimensions Ø 5 x 20 mm (also secures the circuits of the connected controllers and valve gears)	117.40 / I

other / similar items: VOORL terminal strip for heating and cooling in the air conditioning technology section beginning on page 145.
Accessories: suitable valve actuators ZB00A

ACCESSORIES	ITEM NO.	FEATURES	EURO/PG
JZ-32 	BN990005	General features: Magnetic fastening set for simple and safe fastening of the V00PL terminal strip on a metallic substrate (for example, heating manifold)	19.30 / II

TERMINAL STRIP FOR HEATING MANIFOLD FOR 6 OR 8 ROOM THERMOSTATS

ILLUSTRATIONS

V00PL-216.176

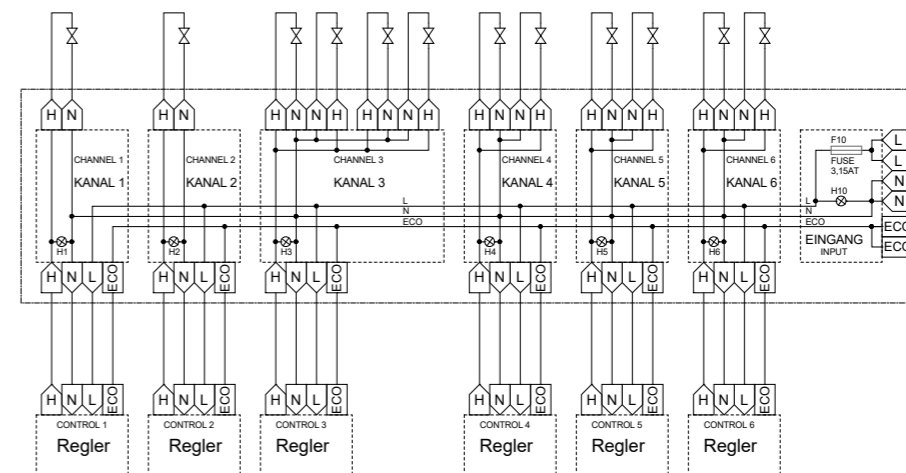

V00PL-318.178

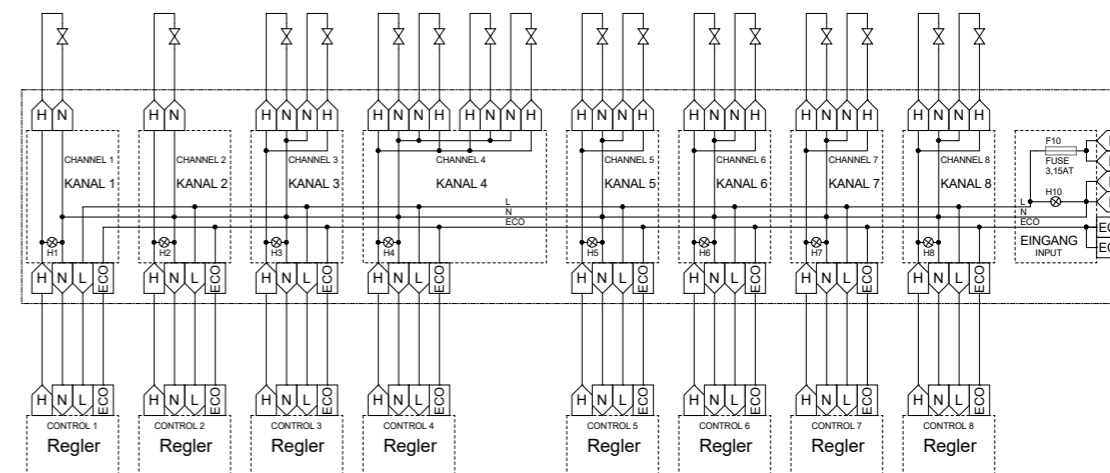

V00PL-216.176

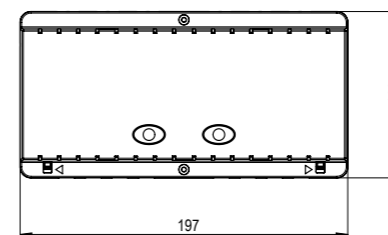
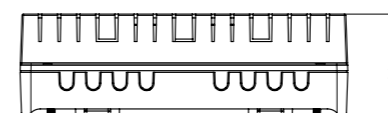

V00PL-318.178

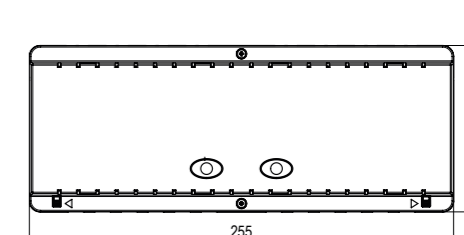
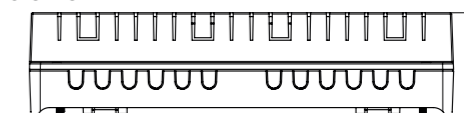



NOTES ON AND EXAMPLES OF WIRING FOR VOOPL TERMINAL STRIPS

1 HEATING SYSTEM WITH MASTER-SLAVE TIME ZONE

The controllers and valve actuators are supplied with power via the terminal strip.

The features and functions of the individual controller types can be found in the overview on page 56.

The information listed in this matrix applies for normally closed valve actuators.

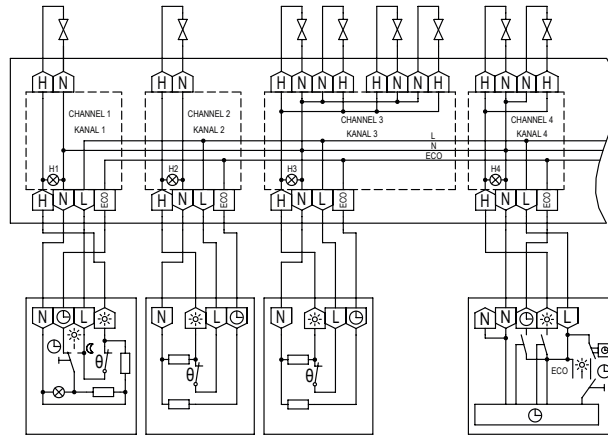

Study RTBSB-201.075 / RTBSU-401.075 (slave)	Children's room RTBSB-201.002 / RTBSU-401.002 (slave)	Living room RTBSB-201.002 / RTBSU-401.002 (slave)	Bedroom HTRRBu 110.117 (master time zone 2 slave)
--	--	--	--

2 COOLING SYSTEM

The controllers and valve actuators are supplied with power via the terminal strip.

The features and functions of the individual controller types can be found in the overview on page 56. The information listed in this matrix applies for normally closed valve actuators.

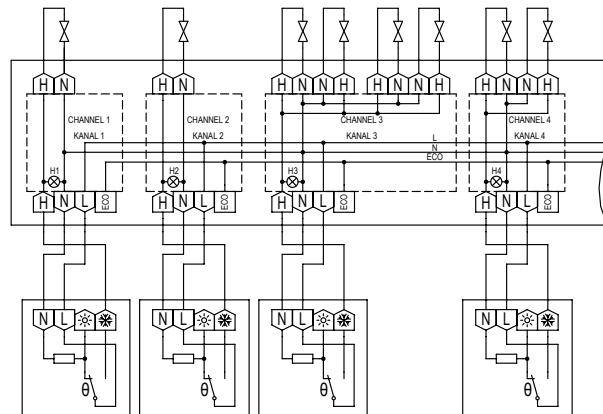

Study RTBSB-201.010 / RTBSU-401.010	Children's room RTBSB-201.010 / RTBSU-401.010	Living room RTBSB-201.010 / RTBSU-401.010	Bedroom RTBSB-201.010 / RTBSU-401.010
---	---	---	---

3 HEATING / COOLING SYSTEMS WITH HEATING / COOLING SWITCHES AT THE CONTROLLERS

The controllers and valve actuators are supplied with power via the terminal strip.

The features and functions of the individual controller types can be found in the overview on page 56.

The printing on the heating / cooling changeover switches on the RTBSU-401.065 and RTBSU-401.063 applies to normally closed valve actuators. The medium status 'hot' or 'cold' must always correspond to the switch settings.

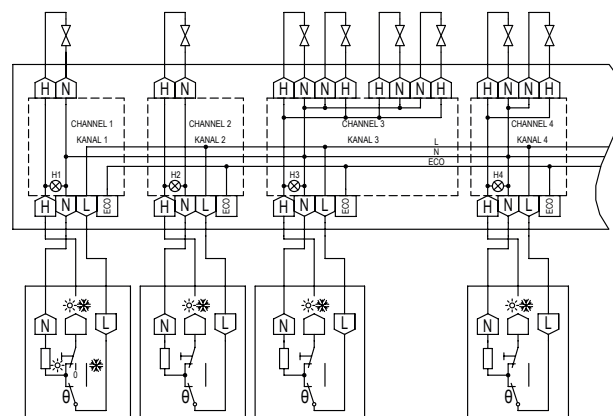

Study RTB- SU-401.063	Children's room RTBSB-201.065 / RTBSU-401.065	Living room RTBSB-201.065 / RTBSU-401.065	Bedroom RTBSB-201.065 / RTBSU-401.065
--------------------------	---	---	---



AIR CONDITIONING TECHNOLOGY



SUSTAINABLE AND PRECISE

ALRE CLIMATE CONTROLLERS. FOR **A PERFECT** **INDOOR CLIMATE.**



OVERVIEW 115

NOVA 116

CLIMATE CONTROLLER

Electronic with triac output (noiseless)	119
Bimetal (mechanical) 'surface-mounted'	120
Electronic, 'surface-mounted' (also for EC fans)	122
Electronic for cooling ceilings or surface heating/cooling systems, 'flush-mounted'	124
Electronic for cooling ceilings or surface heating/cooling systems, 'flush-mounted'	127
Electronic for cooling ceilings or surface heating/cooling systems, 'flush-mounted' with clock (also for EC fans)	131
Continuous electronic climate controller, 'surface-mounted'	137

DEW POINT MONITORING

Dew point monitor	139
Dew point sensor	140

HYGROSTATS / HYGRO-THERMOSTATS

Room 'surface-mounted/flush-mounted'	142
--------------------------------------	-----

TERMINAL STRIPS FOR HEATING/COOLING MANIFOLDS/VALVE ACTUATORS

Terminal strips for heating/cooling manifolds	145
Actuator 'STELLA' 230 V NC	148
Electro-thermal valve actuators	149

Our climate controllers expertly balance humidity and temperature for a comfortable indoor environment, protecting your investments and enhancing comfort. With adjustable programs and display controllers, they offer not only comfort but also sustainability and energy efficiency, aligning with today's growing need for eco-friendly heating solutions amid climate change challenges.

alre climate controller: comfortable indoor climate any time of the year.

APPLICATION EXAMPLES:

- + Cooling ceilings
- + Fan coils
- + Hot water underfloor heating
- + Air distribution systems
- + Partial air conditioners
- + Heat pumps
- + AC split units
- + Dew point monitoring
- + Relative humidity control
- + Accessories such as terminal strips and actuators



ROOM TEMPERATURE CONTROLLER, HEATING/COOLING, SURFACE-MOUNTED, ULTRA-SLIM



ROOM TEMPERATURE CONTROLLER WITH CLOCK, HEATING/COOLING



ROOM TEMPERATURE CONTROLLER, HEATING/COOLING, 3-STAGE FAN OUTPUT



TERMINAL STRIP VOORL-318.053

**WE ARE COOKING UP A
STORM.**

**AND HERE WE ARE
SETTING THE TABLE.**
STAY TUNED IN 2026

CLIMATE CONTROLLER OVERVIEW

TYPE	KTRTB-		KTBSB-			KTRRB-				KTRRU-		KTRRUu		KTRVB-			
	211,108	251,108	112,000	113,500	112,070	117,128	117,163	117,169	052,244	052,245	217,456	257,456	048,100	048,200	052,244	052,245	
PAGE	119	119	120	120	120	122	122	122	124	125	127	131	133	137	137	138	138
HOUSING DESIGN																	
Berlin 1000	x	x															
Berlin 2000									x	x				x	x	x	x
Berlin 3000			x	x	x	x	x	x									
Berlin flush-mounted kit											x	x	x				
SENSOR																	
Bimetal (togger)			x	x	x												
NTC, internal	x	x				x	x	x	x	x	x	x	x	x	x	x	x
NTC, external						x	x	x	x	x	x				x	x	
Floor monitor (NTC)																	
Dew point sensor (external)									x	x	x	x			x	x	
CONTROL TYPE																	
Climate controller	x	x															
Climate controller (0-10 V)												x	x	x	x	x	x
Climate controller with fan output			x	x								x	x				
Climate controller with neutral zone							x		x	x	x					x	x
Climate controller with neutral zone and fan output					x	x		x				x	x				
Mixing chamber controller (0-10 V)														x	x		
PIPE SYSTEM																	
Air conditioning controller as a 2-pipe system	x	x				x	x	x	x	x	x	x				x	x
Air conditioning controller as a 4-pipe system			x	x	x	x	x	x	x	x	x					x	x
APPLICATION EXAMPLES																	
Hot water floor heating									x	x	x	x	x	x	x	x	x
Fan coil			x	x	x	x		x									
Air distribution systems			x		x	x											
Partial air conditioner	x	x	x	x	x	x	x	x	x	x	x	x	x	x	x	x	x
Cooling ceiling	x	x							x	x	x	x	x	x	x	x	x
Heat pump				x													
AC split unit				x													
FEATURES																	
'ECO' input	x	x				x	x	x	x	x	x	x				x	x
Input 'changeover - heating / cooling'	x	x							x	x	x	x				x	x
'Off with frost protection monitoring' input						x	x	x	x	x		x	x				
Switch 'on / off'			x	x	x												
Switch 'on / off with frost protection monitoring'						x	x	x									
Switch 'heating / cooling'																	
Switch 'heating / ventilation / cooling'				x													
Switch 'ECO / comfort / off with frost protection monitoring'												x	x				x
Switch 'fan'			x	x	x	x		x									
Indicator lamp 'ON / OFF'				x	x												
Indicator lamp 'heating mode'																	
Indicator lamp 'heating'	x	x		x					x	x	x	x	x			x	x
Indicator lamp 'cooling'	x	x		x					x	x	x	x	x			x	x
Indicator lamp 'heating / cooling'																	
Indicator lamp 'cooling interruption due to condensate'									x	x	x					x	x
MISCELLANEOUS																	
230 V~	x		x	x	x	x	x	x				x					
24 V~		x							x	x	x		x	x	x	x	x

CLIMATE CONTROLLER ELECTRONIC WITH TRIAC OUTPUT (NOISELESS) SURFACE-MOUNTED 'ULTRA-THIN' INSTALLATION – DESIGN BERLIN 1000



TECHNICAL DATA

Design:	Berlin 1000
Surface finish:	glossy
Housing colour:	pure white, similar to RAL 9010
Housing material:	ABS plastic
Ambient temperature:	0 to 40 °C
Storage temperature:	-20 to +70 °C
Permissible atmospheric humidity:	max. 95% rel. humidity, non-condensing
Electrical connection:	screw-type terminals 0.5 mm ² to 1.5 mm ²
Mounting / attachment:	surface / wall mounting (4-hole assembly on flush-mounted socket)
Protection rating:	IP30
Safety and EMC:	according to DIN EN 60730
Max. power consumption:	< 0.8 W
Switching power:	15 W
Switching element:	triac
Switching contact:	NC contact
Sensor:	NTC, internal
Control function:	heating or cooling
Control range:	5 to 30 °C
Hysteresis:	0 K since control is practically continuous
Proportional range:	approx. 1 K
General features:	ECO function; 'heating / cooling' display; 'off with frost protection monitoring' operating mode; mechanical range restriction; scale: degrees Celsius; external setting

APPLICATION

This controller was specifically designed for heating / cooling regulation of 2-pipe systems used in hotels, homes and offices and can control up to 5 valve actuators (normally closed).

The KTRTB's internal sensor measures the room temperature and activates heating or cooling depending on the deviation from the configured setpoint temperature. As the switching element used is a triac rather than a relay or bimetal, the system operates without bothersome switching sounds.

ECO function: if this function is selected, the temperature is adjusted down by 3 K in heating mode and up by 3 K in cooling mode.

TYPE/IMAGE	ITEM NO.	FEATURES	CIRCUIT DIAGRAM	EURO/PG
	MA700300	Operating voltage: 230 VAC, 50 Hz Protection class: II, if properly mounted Max. switching current: 65 mA Max. switching voltage: 230 VAC, 50 Hz Min. switching voltage: 230 VAC, 50 Hz Output signal: switching PWM (230 VAC, 50 Hz) ECO contact: 230 VAC, 50 Hz, optionally configurable as ECO or OFF function		78.40/I
	MA700302	similar to KTRTB-211.108 but housing colour: traffic / studio white, similar to RAL9016		94.70/I
	MA700400	Operating voltage: 24 VAC, 50 Hz Protection class: III, protective low voltage Max. switching current: 625 mA Max. switching voltage: 24 VAC, 50 Hz Min. switching voltage: 24 VAC, 50 Hz Output signal: switching PWM (24 VAC, 50 Hz) ECO contact: optionally configurable as ECO or OFF function		58.80/I

Accessories: suitable valve actuators ZBOOA

For accessories and dimension schematic see page 67.

MECHANICAL CLIMATE CONTROLLERS KTBSB

SURFACE-MOUNTED INSTALLATION – DESIGN BERLIN 3000



TECHNICAL SPECIFICATIONS

Design:	Berlin 3000
Surface finish:	matt
Housing colour:	pure white, similar to RAL 9010
Housing material:	ABS plastic
Operating voltage:	230 V AC, 50 Hz
Ambient temperature:	0 to 30 °C
Storage temperature:	-20 to +70 °C
Permissible atmospheric humidity:	max. 95% rel. humidity, non-condensing
Electrical connection:	screw-type terminals
Mounting / attachment:	surface / wall mounting or by means of an adapter plate on a flush-mounted socket
Protection rating:	IP30
Protection class:	II, if properly mounted
Safety and EMC:	according to DIN EN 60730
Max. switching current:	6 (3) A
Max. switching voltage:	230 V AC, 50 Hz
Min. switching voltage:	230 V AC, 50 Hz
Switching power:	1380 W
Switching element:	bimetallic contact
Switching contact:	changeover
Output signal:	switching (230 VAC, 50 Hz)
Sensor:	bimetal
Control function:	heating or cooling
Control range:	5 to 30 °C
General features:	mechanical range restriction; thermal feedback; scale: degrees Celsius; on / off switch; external setting

APPLICATION

Control and monitoring of temperatures in closed, dry spaces. Remote control of air conditioners, climate chests, fan coil systems in living and office spaces and doctors' practices. Individual room optimisation in central air conditioning systems (hotels, hospitals etc.).

Suitable for all heating systems. (Please note the maximum switching current.)

MECHANICAL CLIMATE CONTROLLERS KTBSB

SURFACE-MOUNTED INSTALLATION – DESIGN BERLIN 3000

ACCESSORIES	ITEM NO.	FEATURES	EURO/PG
JZ-17	MN990001	General features: Adapter plate for mounting devices on flush-mounted sockets (including fastening screws for mounting the controller on the adapter plate) Surface finish: matt Housing colour: pure white, similar to RAL 9010 Housing material: ABS plastic	8.20 / II

ILLUSTRATIONS

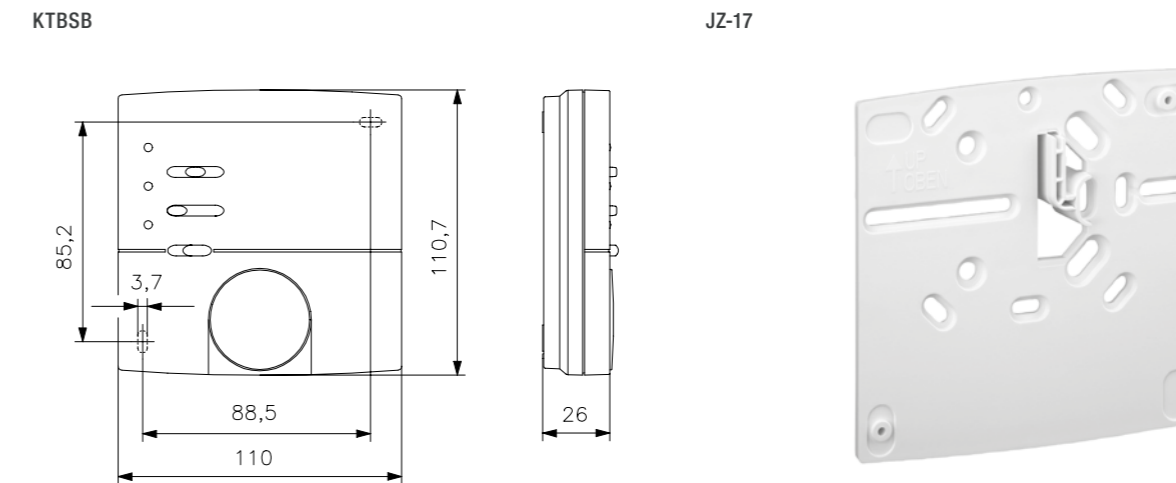

TYPE/IMAGE	ITEM NO.	FEATURES	CIRCUIT DIAGRAM	EURO/PG
	MA200100	General features: 3-stage fan output; 3-stage fan switch; Switch "On / Off" Hysteresis: approx. 0.5 K at a temperature change of max. 4 K/h		96.40 / I
	MA200202	General features: single-room climate controller with neutral zone for 4-pipe systems; 3-stage fan output; 2x auxiliary output 'on / off'; 'on / off' display, 3-stage fan switch; 'on / off' switch Hysteresis: heating approx. 1 K, cooling approx. 2 K, at a temperature change of max. 4 K/h Neutral zone: approx. 2 K		131.20 / I
	MA200000	General features: 'on / off' display; 'heating' display; 'cooling' display; for 4-pipe systems; 3-stage fan output; heating / ventilation / cooling switch; 3-stage fan switch; 'on / off' switch Hysteresis: approx. 0.5 K at a temperature change of max. 4 K/h		133.30 / I

Accessories: Terminal strips V00PL, compatible valve actuators for ZB00A-010.1xx, adapter plates to mount in flush-mounted socket JZ-17
You can find other controllers with outputs for heating / cooling in the 'Heating technology' section (RTBSB / RTBSU).

ELECTRONIC CLIMATE CONTROLLER, KTRRB SURFACE-MOUNTED INSTALLATION – DESIGN BERLIN 3000



TECHNICAL DATA



Design:	Berlin 3000
Surface finish:	matt
Housing colour:	pure white, similar to RAL 9010
Housing material:	ABS plastic
Operating voltage:	230 V AC, 50 Hz
Ambient temperature:	0 to 40 °C
Storage temperature:	-20 to +70 °C
Permissible atmospheric humidity:	max. 95% rel. humidity, non-condensing
Electrical connection:	screw-type terminals
Mounting / attachment:	surface / wall mounting or by means of an adapter plate on a flush-mounted socket
Protection rating:	IP30
Protection class:	II, if properly mounted
Safety and EMC:	according to DIN EN 60730
Max. switching voltage:	230 V AC, 50 Hz
Min. switching voltage:	230 V AC, 50 Hz
Switching element:	relay
Switching contact:	NO contact
Output signal:	switching (230 VAC, 50 Hz)
Sensor:	internal NTC, optional external NTC 'Sensor 2'
ECO contact*:	reduction by 3 K; alternatively, this input can be configured as a frost protection contact
Control function:	heating and / or cooling
Control range:	5 to 30 °C
Neutral zone:	approx. 2 K
General features:	operating mode 'off with frost protection monitoring'; mechanical range restriction; scale: degrees Celsius; external setting

APPLICATION

Single-room temperature controller with neutral zone for 2-pipe or 4-pipe air conditioners.

External flow sensor (H/C sensor): for switching automatically of the controller to heating or cooling mode in 2-pipe operation depending on the inflow temperature; alternatively, this input can be used as an H/C changeover contact.

Sensor rupture and short-circuit Fuse: in case of a sensor rupture or sensor short-circuit, the heating is activated with a power-on-time of 30% to prevent cooling or frost damage in the room.

TYPE/IMAGE	ITEM NO.	FEATURES	EURO/PG
	MA601300	General features: single-room climate controller, 3-stage fan output, fan operation in neutral zone ON / OFF selectable; on / off switch ; 3-stage fan switch Max. switching current: heating 5 (1) A, cooling 5 (1) A, fan 3 (1) A Switching power: heating 1150 W, cooling 1150 W, fan 230 W Hysteresis: approx. 1 K	221.40 / I
	MA601400	Similar to KTRRB-117.128 but without 3-stage fan output and 3-stage fan switch	212.40 / I
	MA601500	General features: single-room climate controller; 'off / manual fan / automatic fan' switch ; 'ventilator 3-stage 0-10 V' switch ; 'parametrisation 3-stage fan output' button; 'heating, cooling, frost protection, sensor rupture or short circuiting of the external sensor' display ; 3-stage fan output 0-10 V with adjustment to individual fan stages or dynamic 0-10 V to activate EC fans ; ON / OFF: ventilator operation in neutral zone selectable Max. switching current: heating 5 (1) A, cooling 5 (1) A Switching power: heating 1150 W, cooling 1150 W Output signal: Analogue 0-10 V (5 mA) for activating an rpm-controlled fan Hysteresis: approx. 0.5 K	231.90 / I

Accessories: Adaptor plate for mounting on flush-mounted socket JZ-17, terminal strips V00xx (see page 145), suitable valve actuators ZB00A-010.1xx (see page 148, page 149, suitable external sensors ('sensor 2'; see 'Sensor technology') You can find other / similar controllers with outputs for heating / cooling in the 'Heating technology' section (RTBSB / RTBSU).

*With ECO operation, the neutral zone (2 K) is extended by the ECO zone (+/- 3 K). ECO operation is a savings mode that should be controlled, for example, via a window contact and / or a timer.

ELECTRONIC CLIMATE CONTROLLER, KTRRB SURFACE-MOUNTED INSTALLATION – DESIGN BERLIN 3000

ACCESSORIES ITEM NO. FEATURES EURO/PG

JZ-17	MN990001	General features: Adapter plate for mounting devices on flush-mounted sockets (including fastening screws for mounting the controller on the adapter plate) Surface finish: matt Housing colour: pure white, similar to RAL 9010 Housing material: ABS plastic	8.00 / II
-------	----------	---	-----------

ILLUSTRATIONS

Circuit diagram KTRRB-117.128

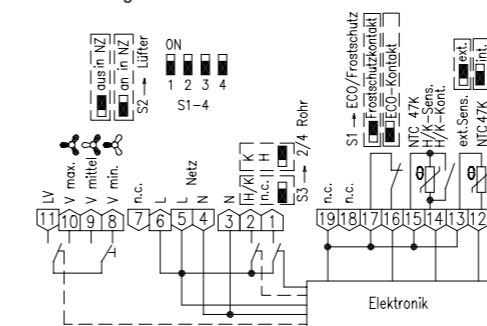

Circuit diagram KTRRB-117.163

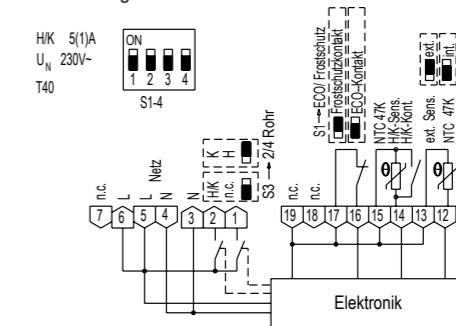

Circuit diagram KTRRB-117.169

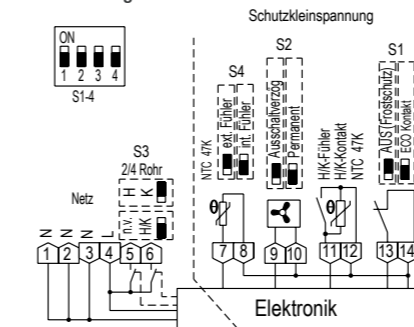

Housing design – 'Berlin 3000'

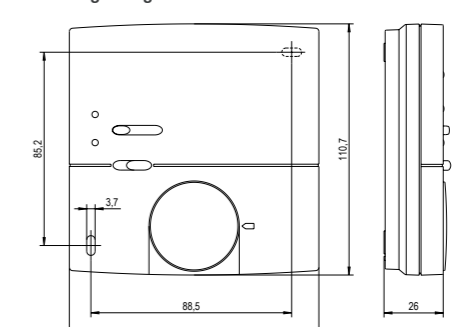

ELECTRONIC CLIMATE CONTROLLER FOR COOLING CEILINGS, KTRRB

SURFACE-MOUNTED INSTALLATION – DESIGN BERLIN 2000 – WITH INTERNAL AND EXTERNAL (OPTIONAL) TEMPERATURE SENSOR



TECHNICAL DATA

Design:	Berlin 2000
Surface finish:	matt
Housing colour:	pure white, similar to RAL 9010
Housing material:	ABS plastic
Ambient temperature:	0 to 40 °C
Operating voltage:	24 VAC / 50 Hz, 24 VDC
Storage temperature:	-20 to +70 °C
Permissible atmospheric humidity:	max. 95% rel. humidity, non-condensing
Electrical connection:	screw-type terminals
Mounting / attachment:	surface / wall mounting
Protection rating:	IP30
Protection class:	III
Safety and EMC:	according to DIN EN 60730
Max. switching current:	1 A
Max. switching voltage:	24 VAC / 50 Hz, 24 VDC
Min. switching voltage:	24 VAC / 50 Hz, 24 VDC
Switching power:	24 W
Switching element:	relay
Switching contact:	NO contact
Output signal:	Switching, 24 VAC / 50 Hz, 24 VDC
Sensor:	NTC internal, optional external, 'Sensor 2'*
Hysteresis:	approx. 1 K
General features:	External dew point sensor connection; mechanical range limitation; external setting

APPLICATION

Temperature controller for cooling ceilings / walls and all kinds of hot water heaters in 2 and 4-pipe systems for hotel, home and office spaces. As the KTRRB features dew point monitoring, it is highly suited for controlling ceiling cooling systems.

The unit can control up to 5 valve actuators (24 V~ normally closed) per output. The types KTRRB-052.24x can be adapted to normally open actuators (24 V~, max. 5 pieces) with a jumper.

When using 0 – 10 V actuators: KTRVB-052.24x.

TYPE/IMAGE	ITEM NO.	FEATURES	CIRCUIT DIAGRAM	EURO/PG
	DA420600	<p>General features: ECO function; 'heating / cooling / cooling interruption due to condensation / off' display; 'sensor rupture, sensor short-circuit, frost protection' display; relative scale</p> <p>External flow sensor (H / C sensor): for automatic switching of the controller in heating or cooling mode depending on the inflow temperature ('Sensor 2'). Alternatively, this input can be used as an H / C changeover contact</p> <p>Eco contact: upon closing the contact, the ECO function is actuated</p> <p>Forced switch-off contact: external switch-off function with frost protection function</p> <p>Control function: heating and / or cooling, cooling interruption upon condensation of the dew point sensor, frost protection function in the switched-off condition</p> <p>Control function: 13 to 29 °C</p> <p>Setting range: -8 to +8 °C</p> <p>Neutral zone: approx. 2 K</p> <p>Pipe system compatibility: 2-pipe and 4-pipe</p>	see page 126	212.50 / I



ELECTRONIC CLIMATE CONTROLLER FOR COOLING CEILINGS, KTRRB

SURFACE-MOUNTED INSTALLATION – DESIGN BERLIN 2000

TYPE/IMAGE	ITEM NO.	FEATURES	CIRCUIT DIAGRAM	EURO/PG
	DA420700	<p>General features: ECO function; 'heating / cooling / cooling interruption due to condensation / off' display; 'sensor break, sensor short-circuit, frost protection' display; operating mode 'off with frost protection monitoring'; relative scale; off / comfort / ECO switch</p> <p>External flow sensor (H / C sensor): for automatic switching of the controller to heating or cooling mode depending on the inflow temperature ('Sensor 2'); alternatively, this input can be used as an H / C changeover contact</p> <p>ECO Contact: upon closing the contact, the ECO function is actuated</p> <p>Forced switch-off contact: external switch-off function with frost protection function</p> <p>Control function: heating and / or cooling, cooling interruption upon condensation of the dew point sensor, frost protection function in the switched-off condition</p> <p>Control range: 13 to 29 °C</p> <p>Setting range: -8 to +8 °C</p> <p>Neutral zone: approx. 2 K</p> <p>Pipe system compatibility: 2-pipe and 4-pipe</p> <p>Replacement for KTRRB-040.213</p>	see page 126	224.40 / I

* An internal trimming potentiometer can be used to select whether control should be based on the internal (left stop) or external sensor (right stop). In the intermediate positions, if both sensors are used, a weighting is applied to the internal room sensor and the external radiation sensor. The weighting allows for compensation of different structural conditions such as large window areas or cardinal directions. For very slow controlled systems, it is recommended to assign a higher weighting to the radiation sensor than to the internal room sensor.

Accessories: suitable valve actuators ZBOOA-040.100 (see page 149), suitable external sensors ('Sensor 2'); see 'Sensor technology'.

ACCESSORIES	ITEM NO.	FEATURES	EURO/PG
	G8000299	<p>Mounting / attachment: using clips on cooling ceiling capillary pipe</p> <p>Use: drywall cooling ceiling (plasterboard) with hung up capillary pipe mat, metal ceiling cooling ceiling with integrated capillary pipe system</p> <p>Sensor line extendable up to: 50 m with 2 x 0.5 mm²</p> <p>Scope of delivery: sensor, 2 clips for cooling pad</p>	69.70 / I
	G8000300	<p>Mounting / attachment: using clips on cooling ceiling capillary pipe or cable ties on the pipe</p> <p>Use: pipe systems transporting cold water, plaster cooling ceiling with capillary tube system</p> <p>Sensor line extendable up to: 50 m with 2 x 0.5 mm²</p> <p>Scope of delivery: sensor, 2 clips for cooling pad, 2 cable ties</p>	69.70 / I
	SN120000	<p>Mounting / attachment: attach to pipe by means of cable ties</p> <p>Use: pipe systems transporting cold water</p> <p>Sensor line extendable up to: 50 m with 2 x 0.5 mm²</p> <p>Scope of delivery: sensor, 2 cable ties</p>	62.40 / I

ELECTRONIC CLIMATE CONTROLLER FOR COOLING CEILINGS, KTRRB

SURFACE-MOUNTED INSTALLATION – DESIGN BERLIN 2000

ILLUSTRATIONS

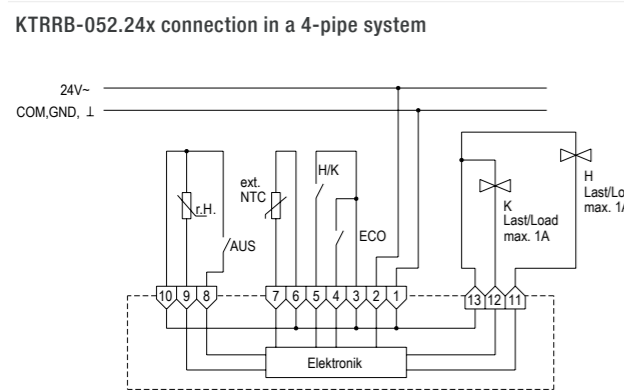
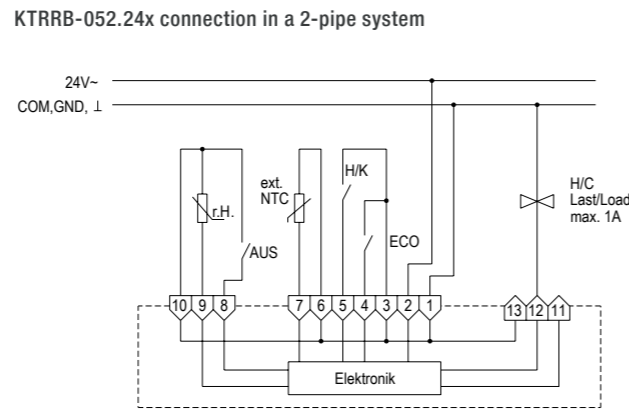
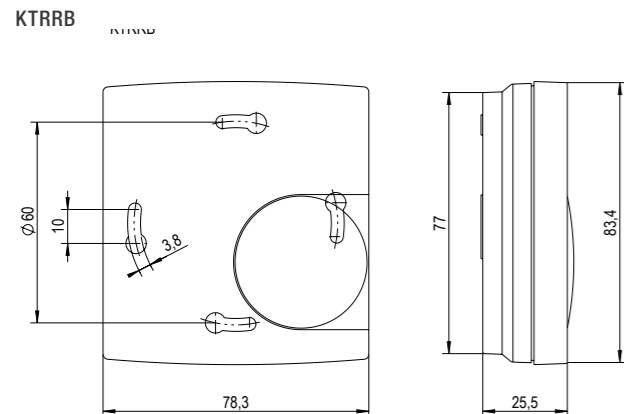

Important note:
The inflow channels of TPS-1 and TPS-2 are closed at the factory to avoid dirtying during assembly. After assembly, they must be shortened with a knife until they are flush with the wall or ceiling to ensure air circulation. The air ducts should be arranged such that soiling during operation is avoided. It is important that the air surrounding the sensor has the same temperature as the room air to be cooled. If the humidity and temperature of the air to be cooled (ceiling cooling system) is different from that of the air surrounding the sensor, condensation may be detected prematurely or too late. As regards TPS-3, contact with the PCB paths must be avoided to prevent long-term corrosion.

Attention in case of sensor extension:
laying parallel to conductors carrying a mains voltage can result in faults. The use of shielded conductors reduces sensitivity to electromagnetic fields.

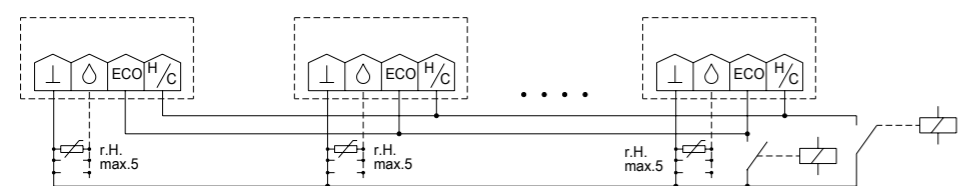

Parallel wiring for heating/cooling changeover and/or ECO for several controllers (max. 20 controllers)

ELECTRONIC CLIMATE CONTROLLER FOR COOLING CEILINGS, KTRRU

– WITH INTERNAL AND EXTERNAL (OPTIONAL) TEMPERATURE SENSOR
– FLUSH-MOUNTED INSTALLATION – DESIGN BERLIN UP



TECHNICAL DATA

Design:	Berlin flush-mounted
Housing material:	PC plastic
Operating voltage:	24 VAC/50 Hz, 24 VDC
Ambient temperature:	0 to 40 °C
Storage temperature:	-20 to +70 °C
Permissible atmospheric humidity:	max. 95% rel. humidity, non-condensing
Electrical connection:	screw-type terminals
Protection rating:	IP30
Protection class:	III
Safety and EMC:	according to DIN EN 60730
Average power consumption:	approx. 0.6 W (1 VA)
Max. switching current:	1 A
Max. switching voltage:	24 VAC/50 Hz, 24 VDC
Min. switching voltage:	24 VAC/50 Hz, 24 VDC
Switching power:	24 W
Switching element:	relay
Switching contact:	NO contact
Output signal:	switching, 24 VAC/50 Hz, 24 VDC
Sensor:	NTC internal, optional external 'Sensor 2'
ECO contact:	when the contact is closed, the ECO function is actuated (+/- 3 K)
Control function:	heating and/or cooling, cooling interruption upon condensation of the dew point sensor, frost protection function in the switched-off condition
Control range:	13 to 29 °C
Setting range:	-8 to +8 °C
Hysteresis:	approx. 1 K
Neutral zone:	approx. 2 K
General features:	single-room climate controller; optional external dew point sensor; ECO function; 'heating/cooling/cooling interruption due to condensation/off' display; mechanical range restriction; relative scale; external setting
Pipe system compatibility:	2-pipe and 4-pipe

APPLICATION

For heating/cooling control of 2- and 4-pipe systems used in hotels, homes and offices.

The unit can control up to 5 valve actuators (24 V~ normally closed) per output. The controllers are configured for 2-pipe or 4-pipe operation by means of a jumper. In 2-pipe operation, the controller is operated with a common heating/cooling output, whose mode of operation action can be toggled by means of an external contact (change-over contact). Connection of TPS dew point sensors is possible (max. 5 of them in parallel). Condensate formation at the TPS can result in the cooling valve getting closed.

It is possible to actuate the energy saving (ECO) function via an external contact.

In the 'off' switch position, the room frost protection function is activated (when the temperature drops below 5 °C, all valves are forced open).

External flow sensor (H/C sensor): for automatic switching of the controller to heating or cooling mode depending on the inflow temperature ('Sensor 2'); alternatively, this input can be used as an H/C changeover contact.



TYPE/IMAGE	ITEM NO.	FEATURES	EURO/PG
KTRRU-052.245#00 	UA210401	<p>General features: 'off with frost protection monitoring' operating mode; 'off/comfort/ECO' switch</p> <p>Surface finish: depending on the cover set selected</p> <p>Housing colour: depending on the cover set selected</p> <p>Mounting/attachment: in flush-mounted socket – adaptable with 50 x 50 mm or 55 x 55 mm cover set in almost all surface switch ranges (deep flush-mounted socket recommended)</p> <p>Accessories: Cover sets are offered in several design variants (see 'Overview', page 129) and are not included in the scope of delivery.</p> <p>Suitable set no.: JZ-007.xxx, e.g.:</p> <p>50 x 50 mm cover set, pure white, glossy: JZ-007.000</p> <p>55 x 55 mm cover set, pure white, glossy: JZ-007.100</p> <p>Scope of delivery: controller, protective cap</p> <p>If the functions of the 'off/comfort/eco' switch are not required, JZ-008.xxx cover sets can be used instead (in switch position comfort).</p>	217.80/1

* An internal trimming potentiometer can be used to select whether control should be based on the internal (left stop) or external sensor (right stop). In the intermediate positions, if both sensors are used, a weighting is applied to the internal room sensor and the external radiation sensor. The weighting allows for compensation of different structural conditions such as large window areas or cardinal directions. For very slow controlled systems, it is recommended to assign a higher weighting to the radiation sensor than to the internal room sensor.

Accessories: suitable valve actuators ZB00A-040.100 (see page 149), dew point sensor TPS 1/TPS 2/TPS 3 (see page 140), suitable external sensors ('Sensor 2'); see 'Sensor technology'.

ELECTRONIC CLIMATE CONTROLLER FOR COOLING CEILINGS, KTRRU

– WITH INTERNAL AND EXTERNAL TEMPERATURE SENSOR –
FLUSH-MOUNTED INSTALLATION – DESIGN BERLIN UP

TYPE/IMAGE	ITEM NO.	FEATURES	EURO/PG
	JZ-090.900	VV000025 General features: alre frame 'Berlin' (neutral) for all flush-mounted controllers with 50 x 50 mm cover Design: Berlin Surface finish: glossy Housing colour: pure white, similar to RAL 9010 Housing material: PC plastic	4.80/I
	JZ-090.100	VV000048 similar to JZ-090.900, but for all flush-mounted controllers in combination with cover 55 x 55 mm	4.80/I
	JZ-090.910	VV000010 General features: alre frame 'Berlin' (neutral) for all flush-mounted controllers with 50 x 50 mm cover Design: Berlin Surface finish: glossy Housing colour: pearl white, similar to RAL 1013 Housing material: PC plastic	4.80/I

ILLUSTRATIONS

Circuit diagram for KTRRU-052.245 in 2-pipe system

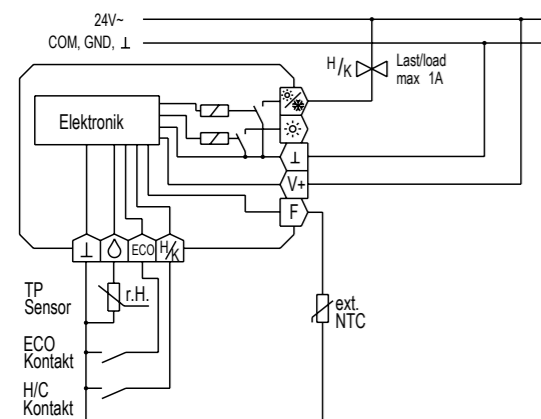

Circuit diagram for KTRRU-052.245 in 4-pipe system

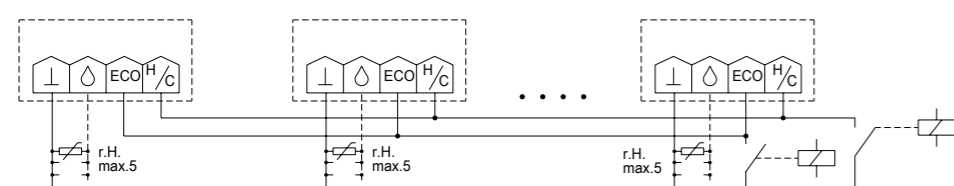
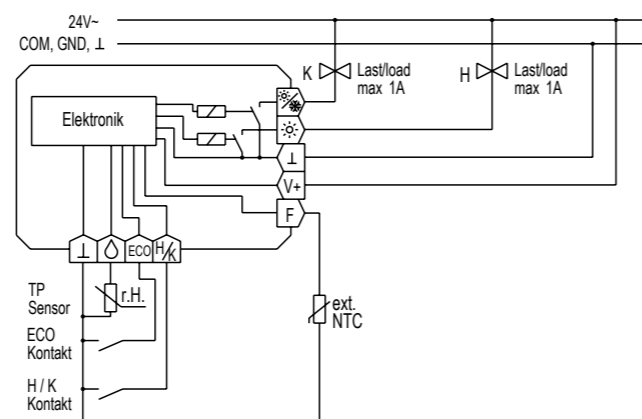

Parallel wiring for heating / cooling changeover and / or ECO for several controllers (max. 20 controllers)

ALRE FLUSH-MOUNTED RANGE (COVER SETS)

ALL BASIC TYPES AND SUITABLE **50 X 50 MM** COVER SETS

BASIC TYPE	50 x 50 mm cover set PURE WHITE (RAL 9010) GLOSSY (JZ-xxx.000)		50 x 50 mm cover set PURE WHITE (RAL 9010) MATT (JZ-xxx.001)		50 x 50 mm cover set PEARL WHITE (RAL 1013) GLOSSY (JZ-xxx.010)		50 x 50 mm cover set TRAFFIC / STUDIO WHITE (RAL 9016) GLOSSY (JZ-xxx.020)		EURO / PG
	Cover set	Item no.	Cover set	Item no.	Cover set	Item no.	Cover set	Item no.	
KTRRU-052.245#00	JZ-007.000	UN990022	JZ-007.001	UN990024	JZ-007.010	UN990026	JZ-007.020	UN990080	13.70/I
Cover sets for function without switch	JZ-008.000	UN990021	JZ-008.001	UN990023	JZ-008.010	UN990025	JZ-008.020	UN990079	13.30/I
FHY 101.060#00	JZ-021.000	UN990039	JZ-021.001	UN990044	JZ-021.010	UN990049	JZ-021.020	UN990081	12.60/I
FRAMES									
alre frame	JZ-090.900	VV000025	JZ-090.910	VV000010					4.80/I

In a flush-mounted socket, it can be adapted to fit virtually any surface switch range.

ILLUSTRATIONS

alre frame 'Berlin' (JZ-090.900)



Cover set (example), individually foil-wrapped

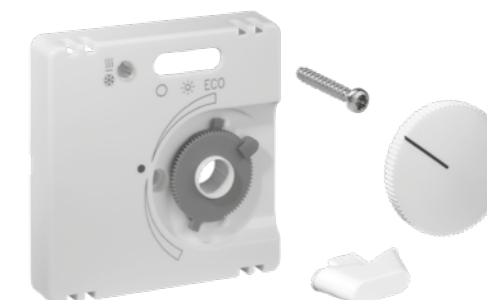

ALL BASIC TYPES AND SUITABLE **55 X 55 MM** COVER SETS

BASIC TYPE	55 x 55 mm cover set PURE WHITE (RAL 9010) GLOSSY (JZ-xxx.000)		55 x 55 mm cover set PURE WHITE (RAL 9010) MATT (JZ-xxx.001)		55 x 55 mm cover set PEARL WHITE (RAL 1013) GLOSSY (JZ-xxx.010)		55 x 55 mm cover set TRAFFIC / STUDIO WHITE (RAL 9016) GLOSSY (JZ-xxx.020)		EURO / PG
	Cover set	Item no.	Cover set	Item no.	Cover set	Item no.	Cover set	Item no.	
KTRRU-052.245#00	JZ-007.100	UN990028	JZ-007.101	UN990030	JZ-007.110	UN990032	JZ-007.120	UN990095	15.50/I
Cover sets for function without switch	JZ-008.100	UN990027	JZ-008.101	UN990029	JZ-008.110	UN990031	JZ-008.120	UN990094	15.00/I
FHY 101.060#00	JZ-021.100	UN990054	JZ-021.101	UN990059	JZ-021.110	UN990064	JZ-021.120	UN990096	13.70/I
FRAMES									
alre frame	JZ-090.100	VV000048							4.80/I

Can be adapted to fit many surface switch ranges in flush-mounted sockets (for a current overview of the suitable frames and insert frames, see page 130).

ILLUSTRATIONS

KTRRU with 50 x 50 insert frame

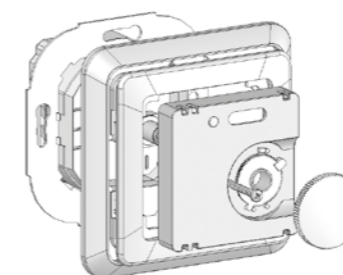

KTRRU without 55 x 55 insert frame

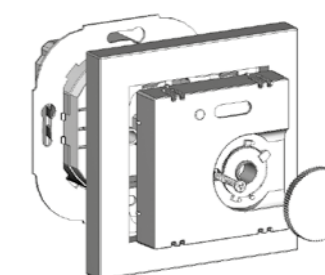

ADAPTATION OF ALRE FLUSH-MOUNTED CONTROLLERS

MANUFACTURER	RANGE	COLOUR RAL 9010 (surface finish)	ADAPTATION possible with '55 x 55' or 'BJ' cover sets (without insert frame)	Only ADAPTATION with '50 x 50' cover set requires an insert frame from the manufacturer
BERKER	S.1	polar white (matt)	x	1109 19 19
BERKER	S.1	polar white (glossy)	x	1109 90 89
BERKER	Arsys	polar white (glossy)		1108 01 69
BERKER	B.3	aluminium / polar white (matt)	x	1109 19 19
BERKER	B.3	aluminium / polar white (glossy)	x	1109 90 89
BERKER	B.7	glass / polar white (matt)	x	1109 19 19
BERKER	B.7	glass / polar white (glossy)	x	1109 90 89
BERKER	Q.1 / Q.3	polar white (velvet)		1109 60 79
BERKER	K.1	polar white (glossy)		1108 71 09
BUSCH-JAEGER	Reflex SI / SI Linear	alpine white (glossy)		1746-214-101
BUSCH-JAEGER	Busch-balance SI	alpine white (glossy)	x	1746-914-101
BUSCH-JAEGER	impuls	alpine white (glossy)		1746 / 10-74
BUSCH-JAEGER	solo / future linear / axcent / etc.	studio white – see RAL 9016 below		
Elso	Joy	pure white (glossy)	x	363084
Elso	Fashion / Riva / Scala	pure white (glossy)		203084
GIRA	surface switch	pure white (glossy)		0282 112
GIRA (System 55)	Standard / E2	pure white (semi-gloss)	x	0282 27
GIRA (System 55)	Standard / E2 / E3	pure white (glossy)	x	0282 03
GIRA (System 55)	E22	pure white (glossy)	x	0282 03
GIRA (System 55)	Event	pure white (semi-gloss) + opaque...	x	0282 27
GIRA (System 55)	Event	pure white (glossy) + opaque...	x	0282 03
GIRA (System 55)	Esprit	pure white (semi-gloss) + glass, aluminium...	x	0282 27
GIRA (System 55)	Esprit	pure white (glossy) + glass, aluminium...	x	0282 03
GIRA	S-Color	pure white (high-gloss)		0282 40
JUNG	CD 500 / CD plus	alpine white (glossy)		CD 590 Z WW
JUNG	A 500 / A 550 / AS 500 / A plus / A flow	alpine white (glossy)	x	A 590 Z WW
JUNG	LS 990	alpine white (glossy)		LS 961 Z WW
JUNG	LS plus	alpine white (glass)		LS 961 Z WW
JUNG	A creation	alpine white (glossy)	x	A 590 Z WW
JUNG	LS Design	alpine white (glossy)		LS 961 Z WW
MERTEN (System M)	M-Smart, M-Plan, M-Pure	polar white (matt)	x	5181 19
MERTEN (System M)	M-Smart, M-Plan, M-Pure	polar white (glossy)	x	5185 19
MERTEN (System Basis)	1-M / Atelier-M	polar white (glossy)	x	5185 19
MERTEN (Surface System)	Artec / Antik	polar white (glossy)		5160 99
MERTEN	1-M / M-Smart / M-Plan / M-Pure / D-Life	active white – see RAL 9016 below or product finder		
PEHA	Standard	pure white (glossy)		80.670.02 ZV
PEHA	Dialog	pure white (glossy)		95.670.02 ZV
PEHA	Aura	pure white (matt) / glass		20.670.02 ZV
PEHA	Badora	pure white (glossy)		11.670.02 ZV

MANUFACTURER	RANGE	COLOUR RAL 9016 (surface finish)	ADAPTATION possible with '55 x 55' or 'BJ' cover sets (without insert frame)	Only ADAPTATION with '50 x 50' cover set requires an insert frame from the manufacturer
BUSCH-JAEGER	solo / future / future linear	studio white (RAL 9016, glossy)		1746 / 10-84
BUSCH-JAEGER	future linear	studio white (RAL 9016 matt)		1746 / 10-884
BUSCH-JAEGER	impuls	studio white (RAL 9016 matt)		1746 / 10-774
BUSCH-JAEGER	axcent	studio white (RAL 9016, glossy)		1746 / 10-84
BUSCH-JAEGER	carat (glass, bronze, gold)	studio white (RAL 9016, glossy)		1746 / 10-84
BUSCH-JAEGER	alpha (nea / exclusive *)	studio white (RAL 9016, glossy)		1746 / 10-24G
BUSCH-JAEGER	alpha (nea / exclusive *)	studio white (RAL 9016 matt)		1746 / 10-24
MERTEN	M-Smart, M-Plan, M-Pure	active white (RAL 9016, glossy)	x	5185 25
MERTEN	1-M / Atelier-M	active white (RAL 9016, glossy)	x	5185 25
MERTEN	D-Life	lotus white (RAL 9016)		MEG4500-6035
PEHA	Standard	arctic		D 80.670 ZV AW

*) During assembly, you need to remove 4 plastic tabs located at the rear of the frame

NOTE: Most switch ranges are designed in a colour similar to RAL 1013, 9016 or 1013, although different switch manufacturers use different designations for this colour. Coloured, glass and aluminium frames are also combined with white jacks or plugs so that controllers with white covers can also be integrated into these frames. Check the precise application in each individual case. The frames have different surface qualities (matt / glossy). For design reasons, the cover of the controller should have the same quality as the frame. We accept no liability for slight variations in colour and surface finish or for accuracy of fit. When installing devices into multi frames, always assemble the temperature controllers at the lowermost position.

'50 x 50 controller': The housing covers of the 50 x 50 controllers are 50 x 50 mm in size. Using a 50 x 50 mm insert frame, they can be integrated into nearly all light switch ranges in accordance with DIN 49075. The 50 x 50 mm insert frames must be ordered from the light switch manufacturer or from a wholesaler. The order number of the insert frame corresponding to the switch range in question can be found in the column 'Only for adaptation with '50 x 50' cover set'.

'55 x 55 controller': The housing covers of the 55 x 55 controllers are 55 x 55 mm in size. Many light switch ranges have inner dimensions of 55 x 55 mm. Therefore, the 55 x 55 controllers can be installed directly in the light switch frame without the use of an insert frame. See the column 'Adaptation with '55 x 55' cover set' to determine whether the 55 x 55 controller fits in the given light switch model (x).

All information regarding switch manufacturers' product lines and item numbers was last updated in 12 / 2022 | No liability is assumed for the information provided. | Technical specifications subject to change.

ELECTRONIC CLIMATE CONTROLLER WITH TIMER KTRRUU – 230 VAC

FLUSH-MOUNTED INSTALLATION – DESIGN BERLIN FLUSH-MOUNTED



TECHNICAL DATA

Design:	Berlin flush-mounted
Housing material:	PC, PMMA, ABS plastic
Ambient temperature:	0 to 40 °C
Storage temperature:	-20 to +70 °C
Permissible atmospheric humidity:	max. 95% rel. humidity, non-condensing
Protection rating:	IP30
Safety and EMC:	according to DIN EN 60730
Max. power consumption:	approx. 1 W (2.2 VA)
Max. switching current:	3 (0.5) A each
Switching element:	2 relays
Switching contact:	2 NO contacts
Output signal:	Switching, analogue 0 to 10 V max. 5 mA for activating an rpm-controlled fan
Sensor:	NTC internal, optional external 'Sensor 2'
External flow sensor (H/C sensor):	For automatic switching of the controller to heating or cooling mode depending on the inflow temperature ('Sensor 2'); alternatively, this input can be used as an H/C changeover contact
ECO contact:	upon closing the contact, the ECO function is actuated
Control range:	5 to 40 °C
Setting range:	standard setting range for heating (5 to 30 °C), second setting range for cooling (18 to 40 °C)
Hysteresis:	approx. 1 K
Neutral zone:	adjustable
Display type:	illuminated graphical display
Pipe system compatibility:	2-pipe and 4-pipe

APPLICATION

Flush-mounted controller with timer function for heating/cooling regulation of 2 and 4-pipe systems used in hotels, homes and offices. The adaptation takes place in a menu. The unit can control up to 5 valve actuators (normally open or normally closed) per output. In 2-pipe operation, the operating mode can be changed via an external changeover contact or temperature sensor. The clock can serve as a master for other controllers for switching to ECO mode. It is possible to activate the energy saving (ECO) or frost protection (OFF) functions via an external contact. Alternatively, the controller's inputs can be configured to connect with an external temperature sensor or dew point sensor (TPS). A 0–10 V interface can be used to control the speed of a fan (**EC fan**).

General: digital surface switch single-room climate controller with timer; optional external dew point sensor; ECO function, ECO value adjustable; 'ECO' display; 'on/off' display; 'heating' display; 'cooling' display; 'cooling interruption' due to condensation; digital actual value display; backlighting; operating mode 'off with frost protection monitoring'; child-safe features; facilities; power-reserve (3 days); actual value correction / measured value correction; learning function; emergency operating mode; holiday setting; party setting; automatic adjustment to summer / winter time; external setting; comfortable operation using touch-sensitive buttons with dynamic button assignment.

Special colours such as anthracite and aluminium are available depending on the project.

TYPE/IMAGE	ITEM NO.	FEATURES	CIRCUIT DIAGRAM	EURO/PG
------------	----------	----------	-----------------	---------

KTRRUu 217.456#21 (230 VAC)



Surface finish: glossy
Housing colour: pure white, similar to RAL 9010
Operating voltage: 230 VAC, 50 Hz
 Electrical connection: pluggable screw-type terminals, voltage supply side 0.75–2.5 mm², low-voltage side 0.08–1.5 mm²
Mounting / Attachment: in flush-mounted socket – adaptable with 50 x 50 mm cover in almost all surface switch ranges (deep flush-mounted socket recommended)
Protection class: II
Max. switching voltage: 230 VAC, 50 Hz
Min. switching voltage: 230 VAC, 50 Hz
Switching power: 690 W
Output signal: switching heating, cooling, heating / cooling, ECO, OFF, 230 VAC, 50 Hz; analogue 0–10 V (5 mA) for activating an rpm-controlled fan
Scope of delivery: controller, 50 x 50 mm cover, pure white (similar to RAL 9010), glossy, alre frame 'Berlin'

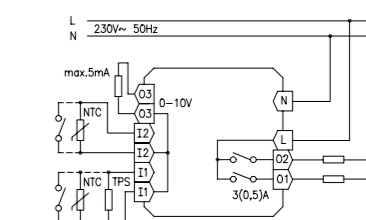

291.30 / I

* A menu setting can be used to select whether control should be based on the internal or external sensor. In the intermediate positions, if both sensors are used, a weighting is applied to the internal room sensor and the external radiation sensor. The weighting allows for compensation of different structural conditions such as large window areas or cardinal directions. For very slow controlled systems, it is recommended to assign a higher weighting to the radiation sensor than to the internal room sensor.

ELECTRONIC CLIMATE CONTROLLER WITH TIMER KTRRUU – 230 VAC

FLUSH-MOUNTED INSTALLATION – DESIGN BERLIN FLUSH-MOUNTED

TYPE/IMAGE	ITEM NO.	FEATURES	CIRCUIT DIAGRAM	EURO/PG
KTRRUu 217.456#07 (230 VAC)	UA220002	Similar to KTRRUu 217.456#21 but scope of delivery as follows: controller, 50 x 50 mm cover pure white (similar to RAL 9010), glossy , without frame		286.80 / I
KTRRUu 217.456#09 (230 VAC)	UA220003	Similar to KTRRUu 217.456#21 but scope of delivery as follows: controller, 50 x 50 mm cover pearl white (similar to RAL 1013), glossy , without frame		286.80 / I
KTRRUu 217.456#27 (230 VAC)	UA220004	Similar to KTRRUu 217.456#21 but scope of delivery as follows: controller, 50 x 50 mm cover traffic / studio white (similar to RAL 9016), glossy , without frame		286.80 / I
KTRRUu 217.456#28 (230 VAC)	UA220007	Similar to KTRRUu 217.456 but scope of delivery as follows: Controller, cover for use with BUSCH-JAEGER Reflex SI / SI Linear pure white (similar to RAL 9010), glossy , without frame		288.80 / I
KTRRUu 217.456#55 (230 VAC)	UA220005	Similar to KTRRUu 217.456#21 but scope of delivery as follows: controller, 55 x 55 mm cover pure white (similar to RAL 9010), glossy , without frame		286.80 / I
KTRRUu 217.456#56 (230 VAC)	UA220009	Similar to KTRRUu 217.456#21 but scope of delivery as follows: controller, 55 x 55 mm cover pure white (similar to RAL 9010), matt without frame		286.80 / I
KTRRUu 217.456#57 (230 VAC)	UA220006	Similar to KTRRUu 217.456#21 but scope of delivery as follows: controller, 55 x 55 mm cover pearl white (similar to RAL 1013), glossy , without frame		286.80 / I
KTRRUu 217.456#59 (230 VAC)	UA220008	Similar to KTRRUu 217.456#21 but scope of delivery as follows: controller, 55 x 55 mm cover traffic / studio white (similar to RAL 9016), glossy , without frame		286.80 / I

ELECTRONIC CLIMATE CONTROLLER WITH TIMER KTRRUU – 24 VAC / VDC

FLUSH-MOUNTED INSTALLATION – DESIGN BERLIN FLUSH-MOUNTED

TYPE/IMAGE	ITEM NO.	FEATURES	CIRCUIT DIAGRAM	EURO/PG
KTRRUu 257.456#21 (24 VAC / VDC)	UA220100	Similar to KTRRUu 217.456#21 but with: Operating voltage: 24 VAC / 50 Hz, 24 VDC Protection class: III Max. switching voltage: 24 VAC / 50 Hz, 24 VDC Min. switching voltage: 24 VAC / 50 Hz, 24 VDC Switching power: 72 W Output signal: switching heating, cooling, heating / cooling, ECO, OFF, 24 VAC / 50 Hz, 24 VDC, analogue 0–10 V (5 mA) to control a speed-controlled fan		291.30 / I
KTRRUu 257.456#07 (24 VAC / VDC)	UA220103	Similar to KTRRUu 257.456#21 but scope of delivery as follows: controller, 50 x 50 mm cover pure white (similar to RAL 9010), glossy , without frame		286.80 / I
KTRRUu 257.456#09 (24 VAC / VDC)	UA220104	Similar to KTRRUu 257.456#21 but scope of delivery as follows: controller, 50 x 50 mm cover pearl white (similar to RAL 1013), glossy , without frame		286.80 / I
KTRRUu 257.456#27 (24 VAC / VDC)	UA220105	Similar to KTRRUu 257.456#21 but scope of delivery as follows: controller, 50 x 50 mm cover traffic / studio white (similar to RAL 9016), glossy , without frame		286.80 / I
KTRRUu 257.456#28 (24 VAC)	UA220108	Similar to KTRRUu 257.456#21 but scope of delivery as follows: Controller, cover for use with BUSCH-JAEGER Reflex SI / SI Linear pure white (similar to RAL 9010), glossy , without frame		288.80 / I
KTRRUu 257.456#55 (24 VAC / VDC)	UA220106	Similar to KTRRUu 257.456#21 but scope of delivery as follows: controller, 55 x 55 mm cover pure white (similar to RAL 9010), glossy , without frame		288.80 / I
KTRRUu 257.456#56 (24 VAC / VDC)	UA220110	Similar to KTRRUu 257.456#21 but scope of delivery as follows: controller, 55 x 55 mm cover, pure white (similar to RAL 9010), matt , without a frame		288.80 / I
KTRRUu 257.456#57 (24 VAC / VDC)	UA220107	Similar to KTRRUu 257.456#21 but scope of delivery as follows: controller, 55 x 55 mm cover pearl white (similar to RAL 1013), glossy , without frame		288.80 / I
KTRRUu 257.456#59 (24 VAC / VDC)	UA220109	Similar to KTRRUu 257.456#21 but scope of delivery as follows: controller, 55 x 55 mm cover traffic / studio white (similar to RAL 9016), glossy , without frame		288.80 / I

Accessories: suitable valve actuators ZB00A-040.100 (see page 149), dew point sensor TPS 1 / TPS 2 / TPS 3 (see page 140), suitable external sensors ('Sensor 2'); see 'Sensor technology'.

ELECTRONIC CLIMATE CONTROLLER WITH TIMER KTRRUU FLUSH-MOUNTED INSTALLATION – DESIGN BERLIN FLUSH-MOUNTED

ACCESSORIES	ITEM NO.	FEATURES	EURO/PG
	JZ-090.900	VV000025 Design: Berlin Surface finish: glossy Housing colour: pure white, similar to RAL 9010 Housing material: PC plastic General features: alre frame 'Berlin' (neutral) for all flush-mounted controllers with 50 x 50 mm cover	4.80 /1
	JZ-090.100	VV000048 Similar to JZ-090.900, but for all flush-mounted controllers in combination with 55 x 55 mm cover	4.80 /1
	JZ-090.910	VV000010 Design: Berlin Surface finish: glossy Housing colour: pearl white, similar to RAL 1013 Housing material: PC plastic General features: alre frame 'Berlin' (neutral) for all flush-mounted controllers with 50 x 50 mm cover	4.80 /1

* A menu can be used to select whether control should be based on the internal or external sensor. In the intermediate positions, if both sensors are used, a weighting is applied to the internal room sensor and the external radiation sensor. The weighting allows for compensation of different structural conditions such as large window areas or cardinal directions. For very slow controlled systems, it is recommended to assign a higher weighting to the radiation sensor than to the internal room sensor.

ILLUSTRATIONS

KTRRUU application example – 2-pipe system (230-V version)

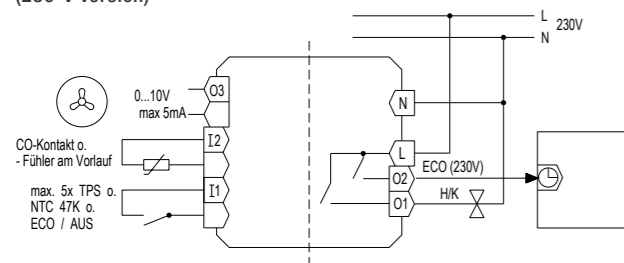

KTRRUU application example – 4-pipe system (230-V version)

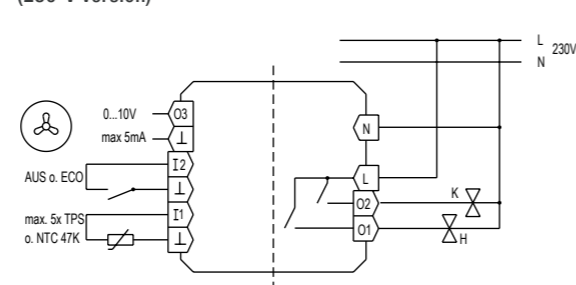

KTRRUU with alre frame 'Berlin'



Pluggable screw-type terminals

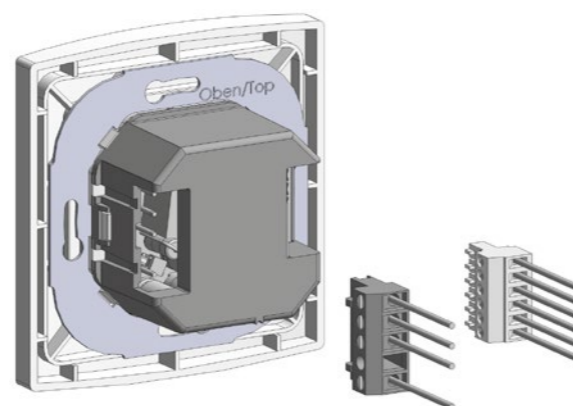

ELECTRONIC CLIMATE CONTROLLER WITH TIMER KTRRUU FLUSH-MOUNTED INSTALLATION – DESIGN BERLIN FLUSH-MOUNTED

ILLUSTRATIONS

KTRRUU with alre frame 'Berlin'

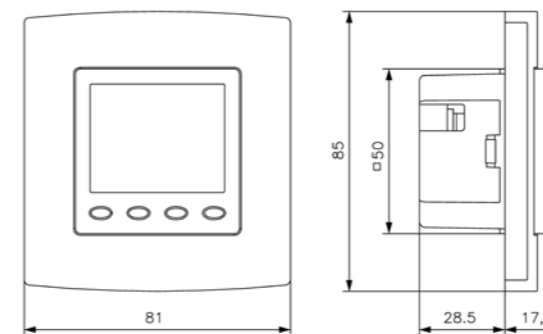

KF-2

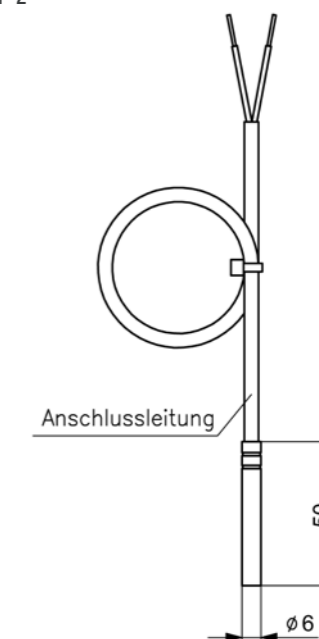

additional benefits:

- Pluggable screw-type terminals facilitate quick and easy assembly
- Illuminated, graphics-capable display
- Automatic adjustment to standard / daylight savings time
- Learn function
- Correction of measurement values
- Configurable display content
- Choice of various languages during installation: (German, English, French, Dutch, Polish, Spanish, Czech, Russian)
- Configurable inputs and outputs, for example:
 - OFF circuit with frost protection
 - ECO input
 - Dew point sensor input
 - Output: heating / cooling / timer master
- Fan control 0–10 V
- Key lock
- Valve protection function
- Configurable control method (PI-PWM or 2-point control)
- Holiday and party function
- Power reserve
- 'Heating mode' indication (LED orange)
- 'cooling mode' indication (LED blue)

ADAPTATION OF ALRE FLUSH-MOUNTED CONTROLLERS KTRRUU 2X7.456

MANUFACTURER	RANGE	COLOUR RAL 9010 (surface finish)	ADAPTATION in switch range (55 x 55) possible with...	'50 X 50' adaptation possible with... (insert frame from manufacturer required)
BERKER	S.1	polar white (matt)	KTRRUu 2x7.456#56	not required
BERKER	S.1	polar white (glossy)	KTRRUu 2x7.456#55	not required
BERKER	Arsys	polar white (glossy)		KTRRUu 2x7.456#07 + 1108 01 69
BERKER	B.3	aluminium / polar white (matt)	KTRRUu 2x7.456#56	not required
BERKER	B.3	aluminium / polar white (glossy)	KTRRUu 2x7.456#55	not required
BERKER	B.7	glass / polar white (matt)	KTRRUu 2x7.456#56	not required
BERKER	B.7	glass / polar white (glossy)	KTRRUu 2x7.456#55	not required
BERKER	K.1	polar white (glossy)		KTRRUu 2x7.456#07 + 1108 71 09
BUSCH-JAEGER	Reflex SI/SI Linear	alpine white (glossy)	KTRRUu 2x7.456#28	not required
BUSCH-JAEGER	Busch-balance SI	alpine white (glossy)	KTRRUu 2x7.456#55	not required
BUSCH-JAEGER	impuls	alpine white (glossy)		KTRRUu 2x7.456#07 + 1746/10-74
BUSCH-JAEGER	solo / future / axcent etc.	studio white – see RAL 9016 below		
EIso	Joy	pure white (glossy)	KTRRUu 2x7.456#55	not required
EIso	Fashion / Riva / Scala	pure white (glossy)		KTRRUu 2x7.456#07 + (203084)
GIRA	surface switch	pure white (glossy)		KTRRUu 2x7.456#07 + 0282 112
GIRA (System 55)	Standard / E2	pure white (semi-gloss)	KTRRUu 2x7.456#56	not required
GIRA (System 55)	Standard / E2 / E3	pure white (glossy)	KTRRUu 2x7.456#55	not required
GIRA (System 55)	E22	pure white (glossy)	KTRRUu 2x7.456#55	not required
GIRA (System 55)	Event	pure white (semi-gloss) + opaque...	KTRRUu 2x7.456#56	not required
GIRA (System 55)	Event	pure white (glossy) + opaque...	KTRRUu 2x7.456#55	not required
GIRA (System 55)	Esprit	pure white (semi-gloss) + glass, aluminium...	KTRRUu 2x7.456#56	not required
GIRA (System 55)	Esprit	pure white (glossy) + glass, aluminium...	KTRRUu 2x7.456#55	not required
GIRA	S-Color	pure white (high-gloss)		KTRRUu 2x7.456#07 + 0282 40
JUNG	CD 500 / CD plus	alpine white (glossy)		KTRRUu 2x7.456#07 + CD 590 Z WW
JUNG	A 500 / A 550 / AS 500 / A plus / A flow	alpine white (glossy)	KTRRUu 2x7.456#55	not required
JUNG	LS 990	alpine white (glossy)		KTRRUu 2x7.456#07 + LS 961 Z WW
JUNG	LS plus	alpine white (glass)		KTRRUu 2x7.456#07 + LS 961 Z WW
JUNG	A creation	alpine white (glossy)	KTRRUu 2x7.456#55	not required
JUNG	LS Design	alpine white (glossy)		KTRRUu 2x7.456#07 + LS 961 Z WW
MERTEN (System M)	M-Smart, M-Plan, M-Pure	polar white (matt)	KTRRUu 2x7.456#56	not required
MERTEN (System M)	M-Smart, M-Plan, M-Creativ, M-Pure	polar white (glossy)	KTRRUu 2x7.456#55	not required
MERTEN (System Basis)	1-M / Atelier-M	polar white (glossy)	KTRRUu 2x7.456#55	not required
MERTEN (Surface System)	Artec / Antik	polar white (glossy)		KTRRUu 2x7.456#07 + 5160 99
MERTEN	1-M / M-Smart / M-Plan / M-Pure / D-Life	active white – see RAL 9016 below		
PEHA	Standard	pure white (glossy)		KTRRUu 2x7.456#07 + 80.670.02 ZV
PEHA	Dialog	pure white (glossy)		KTRRUu 2x7.456#07 + 95.670.02 ZV
PEHA	Aura	pure white (matt) / glass		KTRRUu 2x7.456#07 + 20.670.02 ZV
PEHA	Badora	pure white (glossy)		KTRRUu 2x7.456#07 + 11.670.02 ZV

MANUFACTURER	RANGE	COLOUR RAL 9016 (surface finish)	ADAPTATION in switch range (55 x 55) possible with...	To ADAPT KTRRUu in size '50 x 50', an insert frame from the manufacturer is required
BUSCH-JAEGER	solo / future / future linear	studio white (RAL 9016, glossy)		KTRRUu 2x7.456#27 + 1746 / 10-84
BUSCH-JAEGER	axcent	studio white (RAL 9016, glossy)		KTRRUu 2x7.456#27 + 1746 / 10-84
BUSCH-JAEGER	carat (glass, bronze, gold)	studio white (RAL 9016)		KTRRUu 2x7.456#27 + 1746 / 10-84
BUSCH-JAEGER	alpha (nea / exclusive *)	studio white (RAL 9016, glossy)		KTRRUu 2x7.456#27 + 1746 / 10-24G
MERTEN	M-Smart, M-Plan, M-Pure	active white (RAL 9016, glossy)	KTRRUu 2x7.456#59	not required
MERTEN	1-M / Atelier-M	active white (RAL 9016, glossy)	KTRRUu 2x7.456#59	not required
MERTEN	D-Life	lotus white (RAL 9016)		KTRRUu 2x7.456#27 + MEG4500-6035
PEHA	Standard	arctic		KTRRUu 2x7.456#27 + D 80.670 ZV AW

*) During assembly, you need to remove 4 plastic tabs located at the rear of the frame.

NOTE: Most light switches are designed in the colour 'similar to RAL 9010', although different switch manufacturers use different designations for this colour. Coloured, glass and aluminium frames are also combined with white jacks or plugs so that controllers with white covers can also be integrated into these frames. Check the precise application in each individual case. The frames have different surface qualities (matt/glossy). For design reasons, the cover of the controller should have the same quality as the frame. We accept no liability for slight variations in colour and surface finish or for accuracy of fit. When installing devices into multi frames, always assemble the temperature controllers at the lowermost position.

'50 x 50 controller': The housing covers of the 50 x 50 controllers are 50 x 50 mm in size. Using a 50 x 50 mm insert frame, they can be integrated into nearly all light switch ranges in accordance with DIN 49075. The 50 x 50 mm insert frames must be ordered from the light switch manufacturer or from a wholesaler. The order number of the insert frame corresponding to the switch range in question can be found in the column 'For adaptation of KTRRUu into size '50 x 50'.

'55 x 55 controller': The housing covers of the 55 x 55 controllers are 55 x 55 mm in size. Many light switch ranges have inner dimensions of 55 x 55 mm. Therefore, the 55 x 55 controllers can be installed directly in the light switch frame without the use of an insert frame. See the column 'Adaptation in switch range (55 x 55)' to determine whether the 55 x 55 controller fits in the given light switch range (KTRRUu 2x7.456#xx).

All information regarding switch manufacturers' product lines and item numbers was last updated in 12/2022 | No liability is assumed for the information provided. | Technical specifications subject to change.

CONTINUOUS ELECTRONIC CLIMATE CONTROLLER, KTRVB SURFACE-MOUNTED INSTALLATION – DESIGN BERLIN 2000





TECHNICAL DATA

Design:	Berlin 2000
Surface finish:	matt
Housing colour:	pure white, similar to RAL 9010
Housing material:	ABS plastic
Storage temperature:	-20 to +70 °C
Operating voltage:	24 VDC, 24 VAC, 50 Hz
Permissible atmospheric humidity:	max. 95% rel. humidity, non-condensing
Electrical connection:	screw-type terminals
Mounting / attachment:	surface / wall mounting
Protection rating:	IP30
Protection class:	III
Safety and EMC:	according to DIN EN 60730
Switching element:	electronic with analogue output signal
General features:	climate controller for individual room control with proportionally controlled valve; mechanical range restriction; external setting

APPLICATION

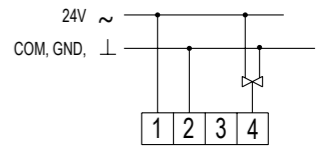
Room temperature controller for continuous control of valve actuators. Controller for 2-pipe systems (1-duct), 4-pipe systems (2-duct) and mixing chambers.

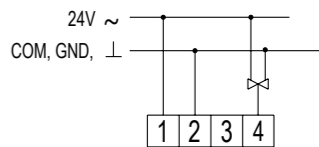
TYPE/IMAGE	ITEM NO.	FEATURES	CIRCUIT DIAGRAM	EURO/PG
	DA450000	General features: scale: degrees Celsius Ambient temperature: 0 to 50 °C Output signal: consistently 0 to 10 V or 10 to 0 V (can be switched using a jumper), max. 5 mA Sensor: NTC internal Control function: heating or cooling with adjustable p-band, aligned to 5 V at setpoint temperature Control range: 5 to 30 °C Hysteresis: 0 K, since control is always via the p-band in the range from +0.5 K to 3 K (adjustable) Pipe system compatibility: 2-pipe		110.00/1
	DA450100	General features: relative scale Ambient temperature: 0 to 50 °C Output signal: consistently 0 to 10 V or +10 to 0 V (can be switched using a jumper), max. 5 mA5 Sensor: NTC internal Control function: heating or cooling with adjustable p-band, aligned to 5 V at setpoint temperature Control range: 13 to 29 °C Setting range: -3 to +3 K (the pre-set 'zero point' of approx. 21 °C can be adjusted in the machine by +/- 5 K) Hysteresis: 0 K, since control is always via the p-band in the range from +0.5 K to 3 K (adjustable) Pipe system compatibility: 2-pipe		118.10/1

CONTINUOUS ELECTRONIC CLIMATE CONTROLLER, KTRVB

SURFACE-MOUNTED INSTALLATION – DESIGN BERLIN 2000

TYPE/IMAGE	ITEM NO.	FEATURES	CIRCUIT DIAGRAM	EURO/PG
	DA451500	<p>General features: external dew point sensor; ECO function; 'heating / cooling / cooling interruption due to condensation / off' display; 'sensor rupture / sensor short-circuit / frost protection' display; operating mode 'off with frost protection monitoring'; relative scale</p> <p>Ambient temperature: 0 to 40 °C</p> <p>Output signal: consistently 0–10 V or 10–0 V (can be switched using a jumper), max. 5 mA</p> <p>Sensor: NTC internal, optional external 'Sensor 2' (see 'Sensor technology')*</p> <p>External flow sensor (H/C sensor): for automatic switching of the controller to heating or cooling mode depending on the inflow temperature; alternatively, this input can be used as a 'Sensor 2' H/C changeover contact</p> <p>ECO contact: upon closing the contact, the ECO function is actuated (in heating mode, the temperature is adjusted down by 3 K and in cooling mode it is adjusted up by 3 K)</p> <p>Forced switch-off contact: external switch-off function with frost protection monitoring</p> <p>Control function: heating and/or cooling with p-band 1 K, cooling interruption upon condensation of the dew point sensor, frost protection function in 'off' state</p> <p>Control range: 13 to 29 °C</p> <p>Setting range: 21 °C ± 8 K</p> <p>Hysteresis: 0 K, since control is always via the p-band in the range from 1 K</p> <p>Neutral zone: approx. 2 K</p> <p>Pipe system compatibility: 2-pipe and 4-pipe</p>		212.50/1

	DA451600	Like KTRVB-052.244 but with 'off/comfort/ECO' switch		224.40/1
--	----------	--	--	----------

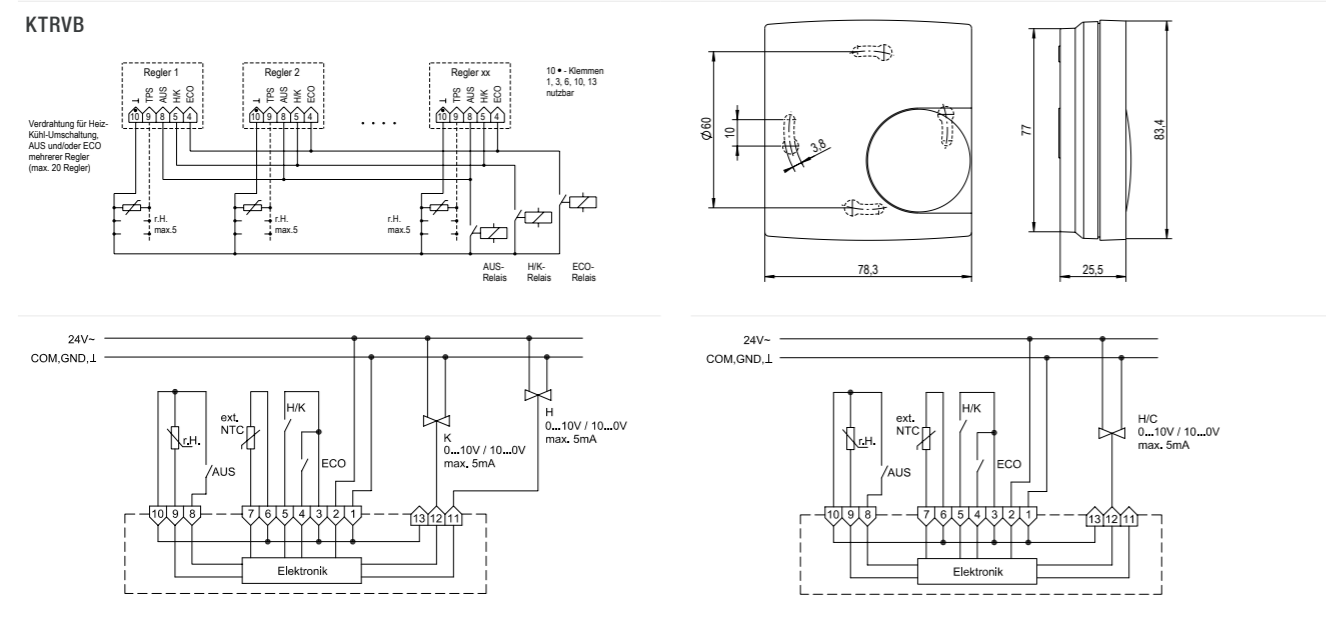

* An internal trimming potentiometer can be used to select whether control should be based on the internal (left stop) or external sensor (right stop). In the intermediate positions, if both sensors are used, a weighting is applied to the internal room sensor and the external radiation sensor. The weighting allows for compensation of different structural conditions such as large window areas or cardinal directions. For very slow controlled systems, it is recommended to assign a higher weighting to the radiation sensor than to the internal room sensor.

ILLUSTRATIONS

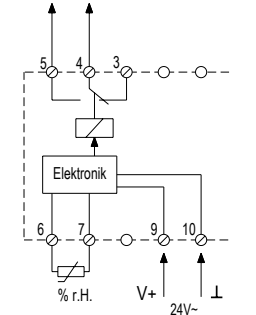

ELECTRONIC DEW POINT MONITOR WFRRN

STANDARD RAIL MOUNTING

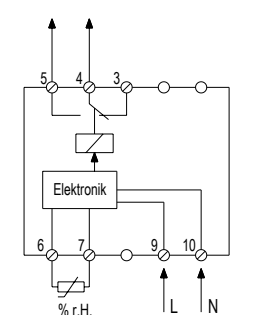
TYPE/IMAGE	ITEM NO.	FEATURES	CIRCUIT DIAGRAM	EURO/PG
	D4780587	<p>Surface finish: matt</p> <p>Housing colour: light grey, similar to RAL 7035</p> <p>Housing material: PC plastic</p> <p>Ambient temperature: 0 to 55 °C</p> <p>Storage temperature: –20 to +70 °C</p> <p>Permissible atmospheric humidity: max. 95% rel. humidity, non-condensing</p> <p>Electrical connection: screw-type terminals up to 2.5 mm²</p> <p>Mounting / attachment: standard rail mounting</p> <p>Protection rating: IP20</p> <p>Safety and EMC: according to DIN EN 60730</p> <p>Average power consumption: approx. 1 VA</p> <p>Min. switching current: depending on the switching voltage (min. 0.3 W)</p> <p>Min. switching voltage: depending on the switching current (min. 0.3 W)</p> <p>Switching element: relay</p> <p>Switching contact: toggler, potential-free</p> <p>Output signal: switching</p> <p>Control function: dew point triggering</p> <p>Hysteresis: 8 MΩ</p> <p>Fixed break point: approx. 98% relative humidity</p> <p>General features: 'dew point triggering' display</p> <p>Accessories: dew point sensors (TPS)</p>		183.50/1
	D4780572	<p>Operating voltage: 24 VDC, 24 VAC, 50 Hz</p> <p>Protection class: III</p> <p>Max. switching current: 10 (3) A at 48 VAC, 10 A at 30 VDC, 1 A at 60 VDC</p> <p>Max. switching voltage: 48 VAC, 50 Hz / 60 VDC</p> <p>Switching power: 500 VA at 48 VAC, 300 W at 30 VDC, 60 W at 60 VDC</p>		187.70/1

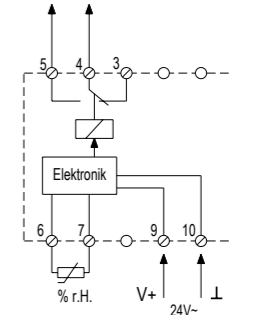
	D4780587	<p>Operating voltage: 24 VDC, 24 VAC, 50 Hz</p> <p>Protection class: III</p> <p>Max. switching current: 10 (3) A at 48 VAC, 10 A at 30 VDC, 1 A at 60 VDC</p> <p>Max. switching voltage: 48 VAC, 50 Hz / 60 VDC</p> <p>Switching power: 500 VA at 48 VAC, 300 W at 30 VDC, 60 W at 60 VDC</p>		183.50/1
---	----------	--	---	----------

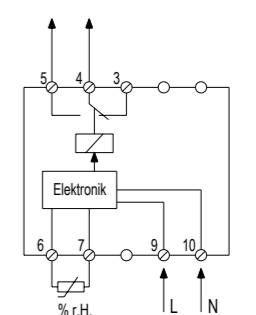
	D4780572	<p>Operating voltage: 230 VAC, 50 Hz</p> <p>Protection class: II, if properly mounted</p> <p>Max. switching current: 10 (3) A at 230 VAC, 10 A at 30 VDC, 1 A at 60 VDC</p> <p>Max. switching voltage: 230 VAC, 50 Hz / 60 VDC</p> <p>Switching power: 2300 VA at 230 VAC, 300 W at 30 VDC, 60 W at 60 VDC</p>		187.70/1
---	----------	---	---	----------

DEW POINT SENSOR, TPS



TECHNICAL DATA

Storage temperature:	-20 to +70 °C
Sensor wire extendible up to:	50 m with 2 x 0.5 mm ²
Connecting cable:	10 m
Accessories:	For use with dew point sensors (e.g., WFRRN) or climate controllers with dew point monitoring (KTRRB, KTRRU, KTRRUu, KTRVB, KTFRL, KTFRD)

APPLICATION

These dew point sensor were developed in conjunction with alre dew point monitors and cooling ceiling controllers for the specific purpose of detecting and signalling the dew point. In this way, they prevent dripping condensation water from reaching the cooling circuit parts, if installed correctly.



TYPE/IMAGE	ITEM NO.	FEATURES	EURO/PG
TPS 1 	G8000299	Mounting / attachment: using clips on cooling ceiling capillary pipe Use: Drywall cooling ceiling (plasterboard) with hung up capillary pipe mat, metal cooling ceiling with integrated capillary pipe system Sensor wire extendible up to: 50 m with 2 x 0.5 mm ² Scope of delivery: sensor, 2 clips for cooling pad	69.70/1
TPS 2 	G8000300	Mounting / attachment: using clips on cooling ceiling capillary pipe or cable ties on the pipe Use: Pipe systems transporting cold water, plaster cooling ceiling with capillary tube system Sensor wire extendible up to: 50 m with 2 x 0.5 mm ² Scope of delivery: sensor, 2 clips for cooling pad, 2 cable ties	69.70/1
TPS 3 	SN120000	Mounting / attachment: attach to pipe by means of cable ties Use: Pipe systems transporting cold water Sensor wire extendible up to: 50 m with 2 x 0.5 mm ² Scope of delivery: sensor, 2 cable ties	62.40/1

ILLUSTRATIONS

TPS 3

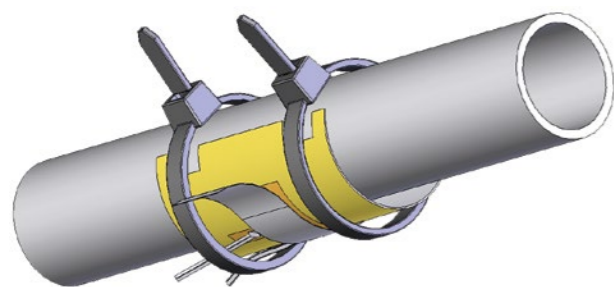

Important note:

The inflow channels of TPS-1 and TPS-2 are closed at the factory to avoid dirtying during assembly. After assembly, they must be shortened with a knife until they are flush with the wall or ceiling to ensure air circulation. The air ducts should be arranged such that soiling during operation is avoided. It is important that the air surrounding the sensor has the same temperature as the room air to be cooled. If the humidity and temperature of the air to be cooled (ceiling cooling system) is different from that of the air surrounding the sensor, condensation may be detected prematurely or too late. As regards TPS-3, contact with the PCB paths must be avoided to prevent long-term corrosion.

Attention in case of sensor extension: Parallel laying to conductors carrying a mains voltage can result in faults. The use of shielded conductors reduces sensitivity to electromagnetic fields.

Mode of operation – dew point sensor:

if the surface temperature of the dew point sensor is equivalent to the dew point, a microscopic film of moisture forms on its surface. This film changes the resistance value of the dew point sensor to such an extent that the connected controller or monitor detects this change and disables the cooling. In this manner, dripping condensate water at maximum cooling, and hence moisture damage to the building, are avoided. When the dew point sensor dries off again, the resistance value increases and cooling is re-enabled. To ensure that a pending undershooting of the dew point is detected in time, the dew point sensor should be assembled at the point where the dew point is most likely to be reached first along the cooling circuit. Generally, these locations are at the inlet coming into the room and /or near windows. If the place where the dew point is likely to occur cannot be unambiguously determined, it is possible to connect up to 5 dew point sensors in parallel to one controller or monitor.

DEW POINT SENSOR, TPS

ILLUSTRATIONS

TPS 3

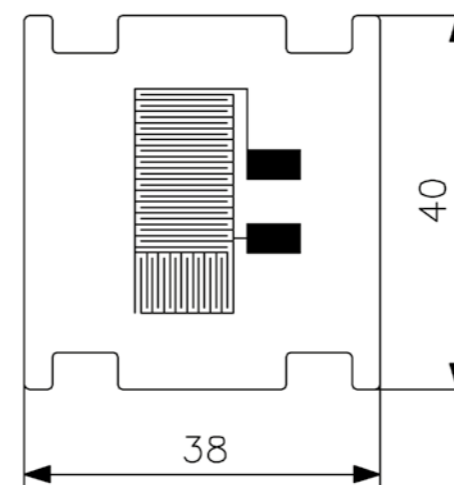

TPS 1

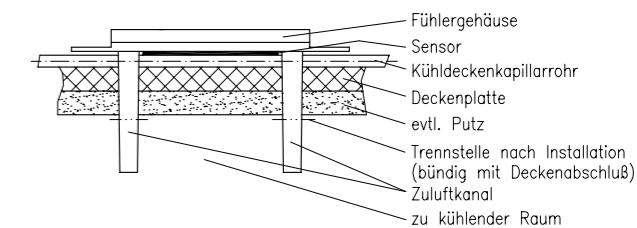

TPS 1

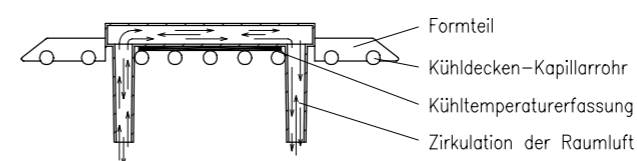

TPS 2

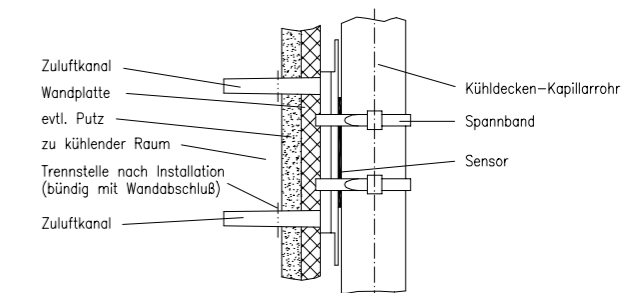

WFRRN

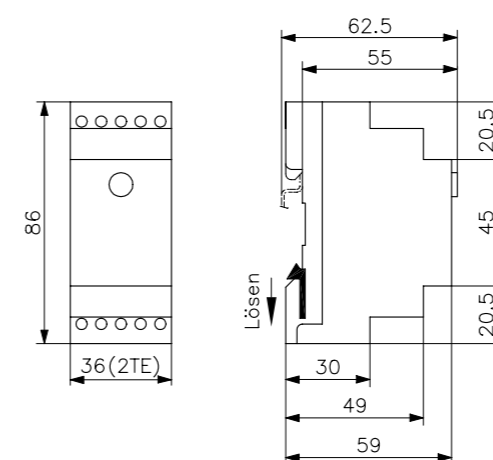

TPS 1/2

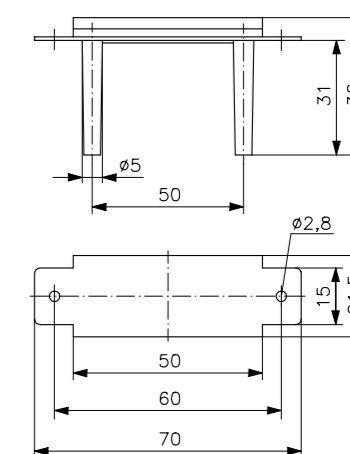

ROOM HYGROSTATS / HYGRO-THERMOSTATS MECHANICAL RFHSB, FHU, RKDSB

SURFACE-MOUNTED INSTALLATION – DESIGN BERLIN 2000 / 3000 / UP



TECHNICAL DATA

Storage temperature: -20 to +60 °C (RFHSB-060.xxx -20 to +70 °C)

Permissible atmospheric humidity: max. 95% rel. humidity, non-condensing

Electrical connection: screw-type terminals

Protection rating: IP30

Protection class: II, if properly mounted

Safety and EMC: according to DIN EN 60730

Min. switching current: 100 mA

Max. switching voltage: 230 V AC, 50 Hz

Min. switching voltage: 24 VAC, 50 Hz

General features: mechanical range restriction

Other / similar items: For duct and control cabinet hygrostats, see 'Plant Engineering' section

APPLICATION

Hygrostat: The room hygrostat is used to monitor and control the relative humidity, e.g., in offices, homes, winter gardens, baths, swimming pools and data centres. The action of the relative humidity on a measuring tape is made to actuate a potential-free changeover contact. The desired value is set by means of the adjusting knob on the front panel. The setting range can be limited.

Hygro-thermostat: Monitoring and control of the relative humidity and the temperature in one device.

Note: Observe the wet room distance according to DIN VDE 0100-701!

TYPE/IMAGE	ITEM NO.	FEATURES	CIRCUIT DIAGRAM	EURO/PG
------------	----------	----------	-----------------	---------

FHY 101.060#00	UA020004	<p>General features: external setting; protective cap; contact hazard protection cover plate</p> <p>Design: Berlin flush-mounted</p> <p>Surface finish: according to selected cover set</p> <p>Housing colour: according to selected cover set</p> <p>Housing material: PC plastic</p> <p>Operating voltage: no auxiliary energy necessary</p> <p>Ambient temperature: 0 to 50 °C</p> <p>Mounting / attachment: in flush-mounted socket – adaptable with 50 x 50 mm or 55 x 55 mm cover set in almost all surface switch ranges (deep flush-mounted socket recommended)</p> <p>Max. switching current: dehumidifying (terminal E) 5 (0.2) A, humidifying (terminal B) 2 (0.2) A</p> <p>Switching power: terminal E: 1150 W, terminal B: 460 W</p> <p>Switching element: microswitch</p> <p>Switching contact: changeover switch (toggler)</p> <p>Output signal: switching</p> <p>Sensor: plastic fibres</p> <p>Control function: humidifying or de-humidifying</p> <p>Control range: 35 to 85% rel. humidity</p> <p>Hysteresis: approx. 5% rel. humidity</p> <p>Accessories: cover sets are offered in several design variants (see 'Overview', page 129) and are not included in the scope of delivery.</p> <p>Suitable set no.: JZ-021.xxx, e.g.: 50 x 50 mm cover set, pure white, glossy: JZ-021.000 55 x 55 mm cover set, pure white, glossy: JZ-021.100</p> <p>Scope of delivery: controller, protective cap</p>		142.60 / I
----------------	----------	--	--	------------

ROOM HYGROSTATS / HYGRO-THERMOSTATS MECHANICAL RFHSB, FHU, RKDSB

SURFACE-MOUNTED INSTALLATION – DESIGN BERLIN 2000 / 3000 / UP

TYPE/IMAGE	ITEM NO.	FEATURES	CIRCUIT DIAGRAM	EURO/PG
------------	----------	----------	-----------------	---------

FHY 101.060#21	UA020003	Similar to FHY 101.060#21 but scope of delivery as follows: controller, alre frame 'Berlin', 50 x 50 mm cover, pure white (similar to RAL 9010), glossy		158.40 / I
RFHSB-060.010	MA020202	<p>General features: External setting</p> <p>Design: Berlin 2000</p> <p>Surface finish: matt</p> <p>Housing colour: pure white, similar to RAL 9010</p> <p>Housing material: ABS plastic</p> <p>Operating voltage: no auxiliary energy necessary</p> <p>Ambient temperature: 0 to 60 °C</p> <p>Mounting / attachment: surface / wall mounting (4-hole assembly on flush-mounted socket)</p> <p>Max. switching current: dehumidifying (terminal 4) 5 (0.2) A, humidifying (terminal 2) 2 (0.2) A</p> <p>Switching power: terminal 4: 1150 W, terminal 2: 460 W</p> <p>Switching element: microswitch</p> <p>Switching contact: changeover switch (toggler)</p> <p>Output signal: switching</p> <p>Sensor: plastic fibres</p> <p>Control function: humidifying or de-humidifying</p> <p>Control range: 35–85% rel. humidity</p> <p>Hysteresis: approx. 7% rel. humidity</p>		93.90 / I
RFHSB-060.011	MA020203	Similar to RFHSB-060.010, but with internal setting		84.60 / I
RKDSB-171.000	MA220000	<p>General features: 'On/off' switch; external setting</p> <p>Design: Berlin 3000</p> <p>Surface finish: matt</p> <p>Housing colour: pure white, similar to RAL 9010</p> <p>Housing material: ABS plastic</p> <p>Operating voltage: 24 VAC or 230 VAC selectable</p> <p>Ambient temperature: 0 to 50 °C</p> <p>Mounting / attachment: surface / wall-mounting or by means of adapter plate on flush-mounted socket</p> <p>Max. switching current: dehumidifying (terminal 9) 5 (0.2) A, humidifying (terminal 8) 3 (0.2) A, heating (terminal 1) 10 (4) A at 230 VAC / 1 (1) A at 24 VAC, cooling (terminal 2) 5 (2) A at 230 VAC / 1 (1) A at 24 VAC</p> <p>Switching power: terminal 9: 1150 W, terminal 8: 690 W, terminal 1: 2300 W at 230 VAC / 24 W at 24 VAC, terminal 2: 1150 W at 230 VAC / 230 W at 24 VAC</p> <p>Switching element: microswitch (hygrostat) / bimetal (thermostat)</p> <p>Switching contact: 2x changeover switch (toggler)</p> <p>Output signal: switching</p> <p>Sensor: plastic fibres for humidity, bimetal for temperature</p> <p>Control function: humidifying or de-humidifying, heating or cooling</p> <p>Control ranges: Temperature 10 to 35 °C, Humidity 30 to 100% rel. humidity</p> <p>Hysteresis: approx. 4% rel. humidity, approx. 1 K at a temperature change of max. 4 K/h</p> <p>Accessories: adapter plate flush-mounted socket mounting: JZ-17</p>		184.80 / I

ROOM HYGROSTATS / HYGRO-THERMOSTATS MECHANICAL RFHSB, FHY, RKDSB

SURFACE-MOUNTED INSTALLATION – DESIGN BERLIN 2000 / 3000 / UP



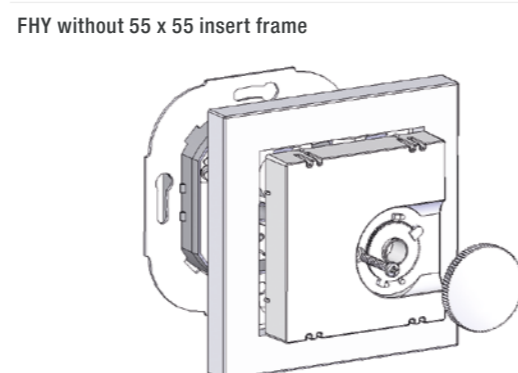
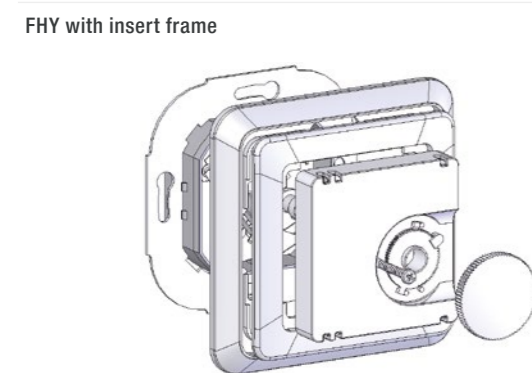
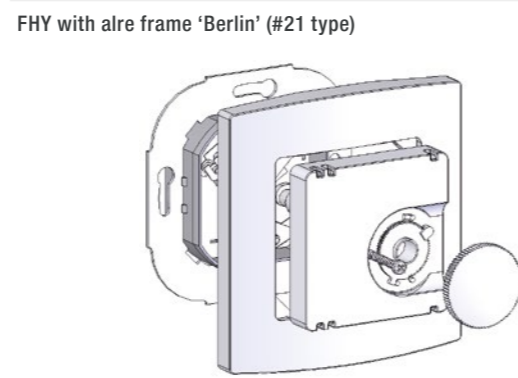
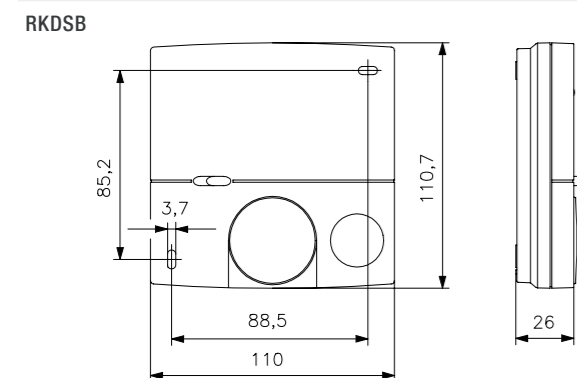
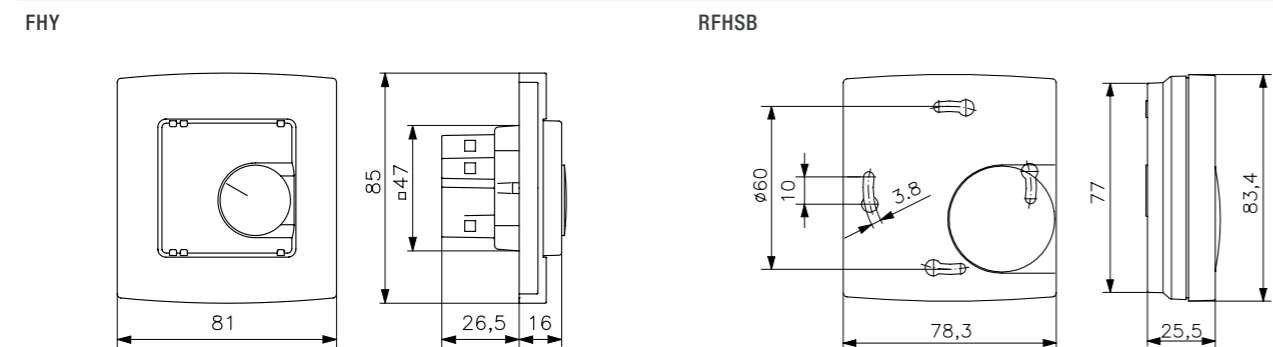

ACCESSORIES	ITEM NO.	FEATURES	EURO/PG
JZ-17 	MN990001	General features: Adapter plate for mounting devices on flush-mounted sockets (including fastening screws for mounting the controller on the adapter plate) Surface finish: matt Housing colour: pure white, similar to RAL 9010 Housing material: ABS plastic	8.20 / II

ILLUSTRATIONS



TERMINAL STRIP FOR HEATING / COOLING MANIFOLD VOORL FOR 5 OR 8 ROOM THERMOSTATS

TECHNICAL DATA	APPLICATION
Surface finish: matt Housing colour: light grey, similar to RAL 7035 Housing material: ABS plastic Operating voltage: 230 V~ Ambient temperature: -10 to +50 °C Storage temperature: -20 to +70 °C Permissible atmospheric humidity: max. 95%, non-condensing Electrical connection: screw-type terminals 0.2 mm ² – 1.5 mm ² max. 180 VA Connectable pump power: T3,15 / 250 V, Ø 5 x 20 mm Device fuse: T3,15 / 250 V, Ø 5 x 20 mm Mounting / attachment: surface mounting / wall mounting on a wall using screws or magnetic bases on a magnetic substrate Protection rating: IP20 Protection class: II, if properly mounted Max. number of valve actuators: number of ducts x 4 for each duct, Duct 1 and 2 as well as 5 and 6 combinable Assignment of ducts to rooms as desired	This device is specifically designed for fixed wiring of 230 VAC single-room temperature controllers and the associated valve actuators for fixed-location attachment. Switching between heating / cooling is performed via a central contact. Heating controllers with changeover contact (e.g., RTBSB-201.010) can be connected as controllers. A master-slave time zone can be formed by using a clock controller. The time zone can also be switched to ECO function via an external switching contact at terminal U. The VOORx-318.053 and VOORx-215.053 units feature an integrated pump function.

TYPE/IMAGE	ITEM NO.	FEATURES	EURO/PG
VOORL-215.009 	DA490110	General features: Terminal strip in housing for wiring up to 5 room thermostats and up to 20 actuators; up to 4 actuators per channel can be connected Max. switching current: output 1-5: 3 (1) A Total of all the outputs (5 channels): 3 (1) A Switching power: total of 920 W ECO contact: if clock regulators are used, a time zone can be defined that can be switched to ECO function via an external switching contact on terminal U Control function: heating or cooling	230.00 / I
VOORL-215.053 	DA490310	As for VOORL-215.009, but including pump module (max. 0.75 A)	249.20 / I
VOORL-318.009 	DA490010	General features: Terminal strip in housing for wiring up to 8 room thermostats and up to 32 actuators; up to 4 actuators per channel can be connected Max. switching current: output 1-8: 3 (1) A Total of all the outputs (8 channels): 3 (1) A Switching power: total of 1380 W ECO contact: if clock regulators are used, a time zone can be defined that can be switched to ECO function via an external switching contact on terminal U Control function: Heating or cooling	282.90 / I
VOORL-318.053 	DA490210	As for VOORL-318.009, but including pump module (max. 0.75 A)	303.30 / I

ACCESSORIES	ITEM NO.	FEATURES	EURO/PG
JZ-24 	BN990002	Magnetic fastening set for simple and safe fastening of the multi-channel receiver and VOORL terminal strips on a metallic substrate (for example, heating manifold)	25.80 / II

TERMINAL STRIP FOR HEATING / COOLING MANIFOLD VOORL FOR 5 OR 8 ROOM THERMOSTATS

ILLUSTRATIONS

VOORL-215.xxx

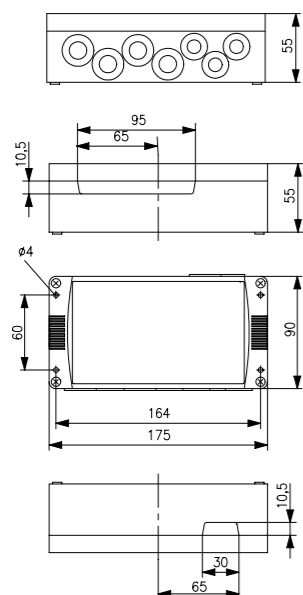

VOORL-318.xxx

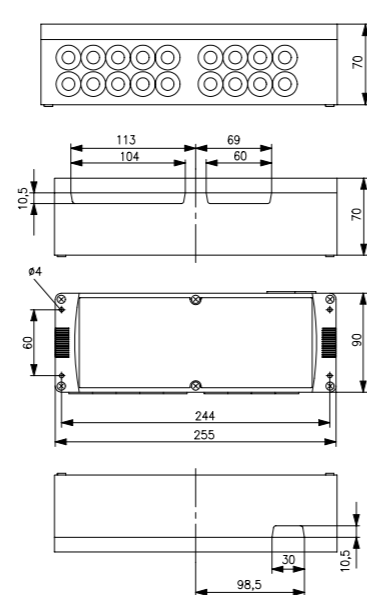

VOORL-318.xxx

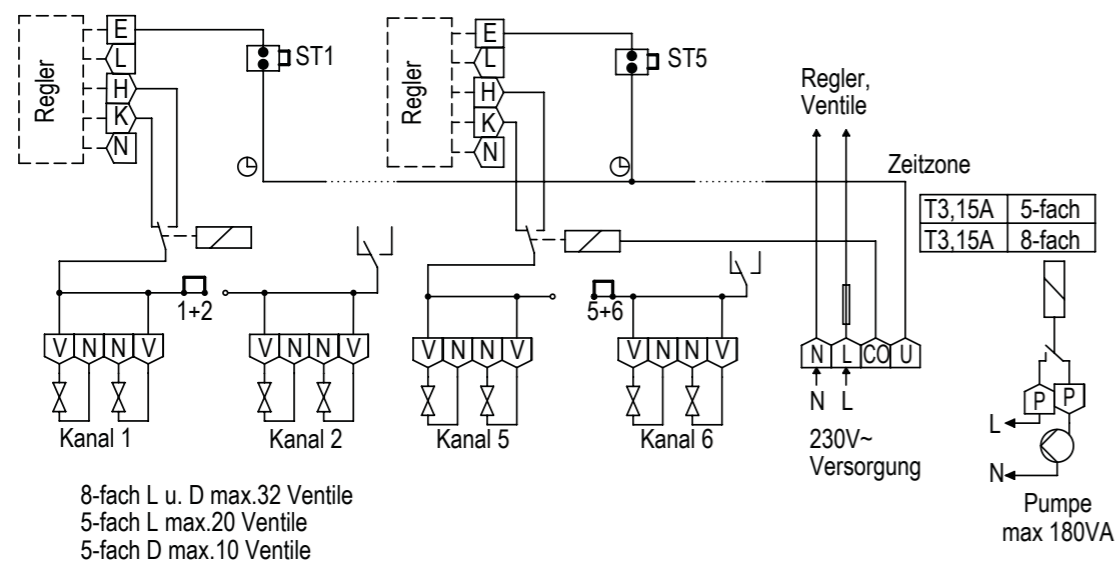

Internal view VOORL-318.xxx



NOTES ON AND EXAMPLES

FOR WIRING THE VOORL TERMINAL STRIPS

SETTING UP TIME ZONES

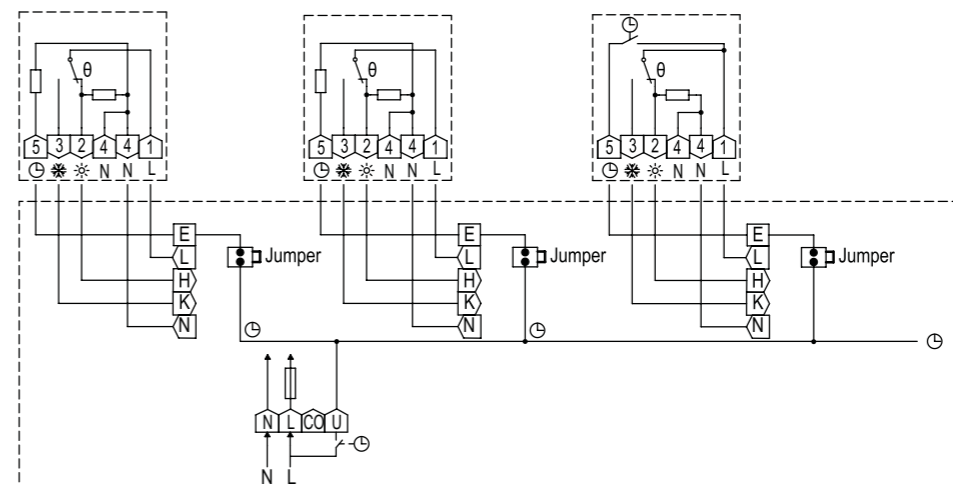

TZ = time zone

INVERSION OF THE CO CONTACT

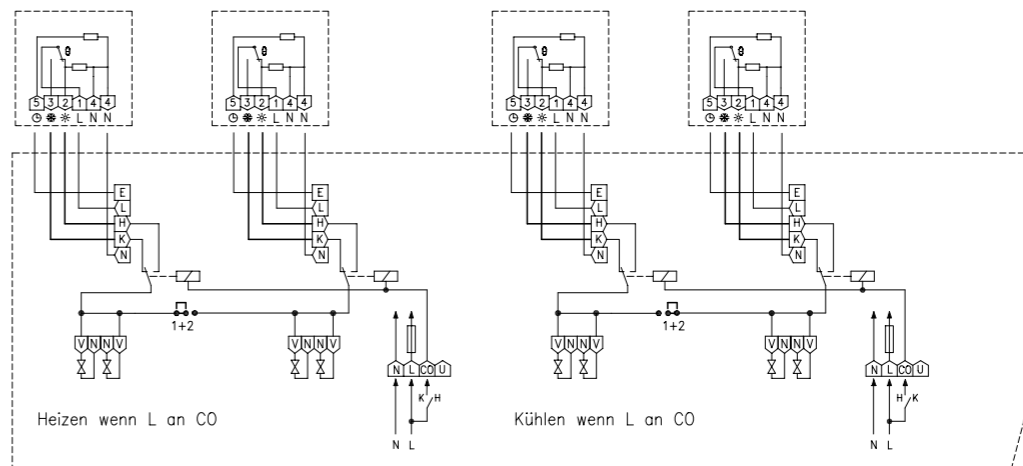

STANDARD WIRING AND COMBINATION OF CHANNEL 1/2

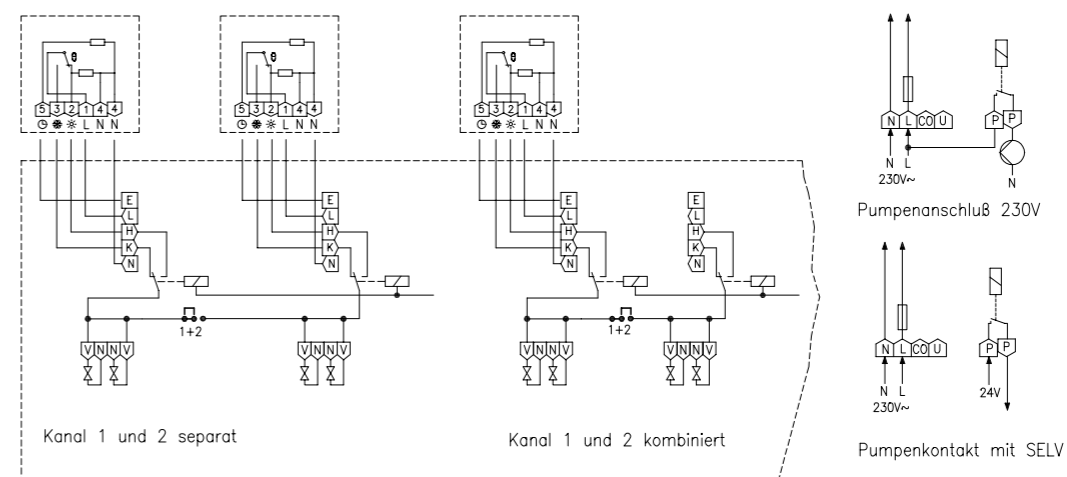

ACTUATOR 'STELLA' 230 V NC FOR AUTOMATIC HYDRAULIC COMPARISON

TECHNICAL DATA

Operating voltage:	230 V~, 50 Hz
Max. power consumption:	30 W
Max. starting current:	approx. 0.13 A
Housing colour:	grey-orange
Housing material:	PA6 plastic
Ambient temperature:	0 to 50 °C
Storage temperature:	-25 to +60 °C
Permissible atmospheric humidity:	Max. 95% rel. humidity, non-condensing
Mounting / attachment:	M 30 x 1.5
Protection rating:	IP54
Protection class:	II
Safety and EMC:	according to DIN EN 60730
Average power consumption:	approx. 1.7 W
Opening / closing time:	approx. 3 min
Nominal stroke:	3.5 mm
Function type:	normally closed
Nominal closing force:	110 N
Connecting cable:	1 m / 2 x 0.34 mm ²

APPLICATION

'Stella' – the intelligent autonomous 230 VAC NC electrothermal actuator for automatic adaptive hydraulic balancing of heating manifolds' heating circuits in surface heating and surface cooling systems.

Sensors on the supply and return lines measure temperature differences, and an algorithm continuously calculates the necessary temperature spread and the appropriate valve position.

Normally closed and features a folding lever for easily unscrewing the thermostat valve or opening it manually when it is disconnected from the mains. Features integrated inflow temperature limitation.

Can be combined with all standard temperature controllers and terminal strips (except devices with triac switching element).



TYPE/IMAGE	ITEM NO.	FEATURES	CIRCUIT DIAGRAM	EURO/PG
ZB00A-010.185	G8990010	Actuator for automatic hydraulic balancing		86.40 / I
SET 31	VV000046	Set for performing fully automatic hydraulic balancing consisting of 5 surface-mounted room thermostats, 1 terminal strip and 6 actuators.		818.70 / I
SET 32	VV000047	Set for performing fully automatic hydraulic balancing consisting of 5 flush-mounted room thermostats, 1 terminal strip and 6 actuators.		913.90 / I

ILLUSTRATIONS

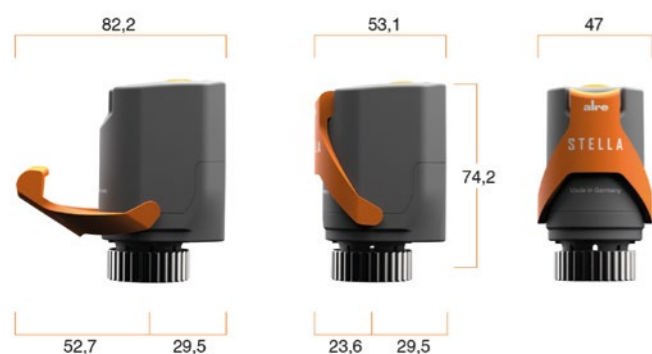

BRIEF DESCRIPTION

- Combinable with the commercial 2-point room temperature controllers (electromechanical, electronic, PWM), except devices with triac switching element
- for heating and cooling systems
- Features a folding lever for easily unscrewing the thermostat valve or opening it manually when it is disconnected from the mains
- Temperature sensors suited for surface heating pipes made of plastic, metal or combinations thereof with an external diameter of 12 to 20 mm
- measures a heating circuit's outflow temperature
- The range of setpoint temperatures Stella calculates is variable and dependent on user behaviour and the system's environment
- The valve can be adjusted to any desired position between OPEN and CLOSED and set to remain in that position.
- An expansion element and a stroke measuring system are needed to position the valve stroke.

ELECTRO-THERMAL VALVE ACTUATORS FOR HEATING, VENTILATION AND AIR CONDITIONING TECHNOLOGY

TECHNICAL DATA

Housing colour:	pure white, similar to RAL 9010
Housing material:	PC plastic, GF (20%)
Ambient temperature:	0 to 50 °C
Storage temperature:	-20 to +70 °C
Permissible atmospheric humidity:	max. 95% rel. humidity, non-condensing
Mounting / attachment:	M 30 x 1.5
Protection rating:	IP42
Protection class:	II
Safety and EMC:	according to DIN EN 60730
Average power consumption:	approx. 3 W
Opening / closing time:	approx. 4 min
Nominal stroke:	3 mm
Function type:	normally closed
Nominal closing force:	90 N
Connecting cable:	0.8 m / 2 x 0.5 mm ²
Valve position indicator:	2X (at the top and the side)

APPLICATION

Extremely compact design: can be fitted quickly and comfortably thanks to the slim shape in the area around the fastening nut.

Can be fitted in any position: lateral drainage holes carry off any leakage water that from the valve plunger into the open, thus avoiding damage to the drive.

Additional valve monitoring: two additional viewing windows at the side allow users to visually check the respective valve position with ease; this does not work when mounted in a suspended manner.



TYPE/IMAGE	ITEM NO.	FEATURES	EURO/PG
ZB00A-010.100	H9100010	Operating voltage: 230 V~, 50 Hz Max. power consumption: 70 W Max. starting current: approx. 0.3 A	33.80 / I
ZB00A-040.100	H9100000	Operating voltage: 24 VDC or 24 VAC Max. power consumption: 12 W Max. starting current: approx. 0.5 A	33.80 / I

Thanks to their M 30 x 1.5 fastening and their characteristics (normally closed), the actuators are suitable for the following valve and distributor makes: Beulco, Empur, Heimeier, Kamo, Oventrop, Purmo, SBK, SKV, Strawa, Taconova, Watts

Brief description:

The drive features a compact, space-saving design. The device can be mounted easily thanks to its narrowed shape, especially in the fastening area of the nut. The connecting cable is not located near the fastening nut. This reduces the probability of contact with equipment carrying hot water. Since the fastening nut allows continuous screwing onto the thread, by unscrewing the nut by two or three turns, it is possible to open the valve in an electrically de-energised state – something that cannot be done with bayonet couplings and impulse couplings. Discharged water is dissipated via a draining system. Gaskets are not required thanks to the special design.

The dual position display has the following advantages:

The upper display provides the option of a visual or, in conditions of bad visibility, tactile function test of the drive. The lower viewing windows allow an additional check to determine whether the valve to be actuated follows the lifting movement of the drive. At the beginning of the heating period, it can happen off and on that the valve plungers get 'stuck'. Therefore, with the additional display, it is possible to determine whether the cause lies with the actuator or with the valve in the event the valve does not open. However, that is not possible when mounted in a suspended manner.

ILLUSTRATIONS

Valve actuator

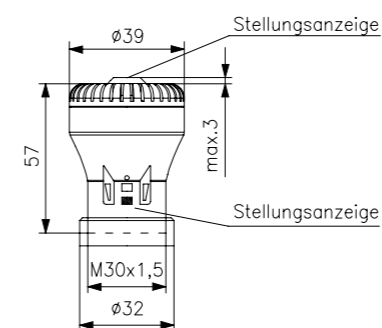

Valve actuator with extended push rod





PLANT ENGINEERING

ROBUST AND VERSATILE



ALRE PLANT ENGINEERING SMOOTHER AND LONGER RUNNING SYSTEMS.



APPLICATION EXAMPLES:

- + Temperature control/safety temperature control, for example, in air ducts, boiler systems, storage tanks, heating coils, burners, pipelines etc.
- + Frost protection for hot water heating coils
- + Temperature and humidity control in control cabinets
- + Humidity control in ventilation and air-conditioning ducts
- + Flow monitoring, for example, in ducts, supply and exhaust air devices of fans, water pipes and oil, cooling and lubrication circuits etc.
- + Pressure monitoring of gaseous media, for example, for filter monitoring, fume hoods, fans, heating coils, low air pressure safety devices and limit controllers



PLANT ROOM THERMOSTAT



UNIVERSAL CAPILLARY DOUBLE THERMOSTAT

OVERVIEW

154

CAPILLARY AND WET ROOM THERMOSTATS, FROST PROTECTION THERMOSTATS

Plant room thermostats (1 and 2-setting ranges), wet room thermostats	162
Universal capillary thermostat (boiler thermostat, ventilation thermostat or contact thermostat)	166
Single-stage plant room thermostats with adjustable switching differential	173
Capillary thermostats (1-, 2-stage) 0.5–4.5 m	174
Contact thermostats	177
Frost protection thermostats/monitors	178
Duct thermostats, ventilation thermostats (TR, TW, STB), air heater thermostats	184

CONTROL CABINET CONTROLLERS

Control cabinet thermostats, electronic	188
Control cabinet thermostats	190
Control cabinet hygrometers	191

TEMPERATURE CONTROLLERS, ELECTRONIC

Controller for distributor assembly (hat rail)	192
Universal controller (wall-mounting)	194

HUMIDITY, (AIR)FLOW AND PRESSURE MONITORING

Mechanical hygrometers	195
Wind indicator relays	197
Differential pressure switches ('pressure cells')	198
Airflow monitors	200
Flow monitor for liquid media	201
Universal pressure switch	206

Our devices are built to perform reliably in tough conditions and heavy usage, meeting the rigorous demands of modern industrial environments. Our range includes devices for monitoring humidity, flow, and pressure, suitable for various applications like air systems, greenhouses, and wind tunnels. The new RTKSA universal capillary controller is a standout, offering flexibility for industrial use with various mounting and measuring options. This versatility is ideal for technicians and simplifies choices for wholesalers, making it a versatile solution for a wide array of industrial requirements.

alre system technology: for perfectly functioning systems.



PLANT ENGINEERING OVERVIEW 3

AIR HEATER THERMOSTATS (DUCT ROD SENSORS WITH CAPILLARY SYSTEM, FUNCTION WITHOUT SUPPLY VOLTAGE)

TYPE	JTL-					JTU-					
	2	8	11	8 NR	17 NR	50	1	3	20	5	6
PAGE	184	184	184	184	184	186	186	186	186	186	186

DEVICES											
Duct thermostat						X	X	X	X	X	X
Air heater thermostat	X	X	X	X	X						

CAPILLARY LENGTH											
Capillary 350 mm	X	X		X		X	X	X		X	X
Capillary 1,250 mm			X		X				X		

CONTROL RANGE											
-25 to +65 °C						X					
20 to 70 °C	X	X	X	X	X						
20 to 100 °C							X	X	X		
60 to 140 °C										X	X
70 to 95 °C				X	X						
70 to 100 °C	X	X	X								
100 °C rod fixed				X	X						

OUTPUT											
Microswitch (potential-free changeover contact)	X	X	X	X	X	X	X	X	X	X	X

SWITCHING POWER											
15 (8) A, 24-250 V~	X	X	X	X	X	X	X	X	X	X	X

DEGREE OF PROTECTION											
IP40	X	X	X	X	X	X	X	X	X	X	X

MISCELLANEOUS											
Type testing by TÜV in accordance with DIN EN 14597	X	X	X	X	X			X	X		
Temperature monitor	X		X	X	X	X	X				X
Temperature limiter											X
Safety temperature limiter internal setting	X	X	X	X	X	X	X	X	X	X	X



PLANT ENGINEERING OVERVIEW 4

CONTACT AND FROST PROTECTION THERMOSTATS

TYPE	ATR			JTF-													RTKSA-																
	83.000	83.100	83.001	83.101	1	1/12	1W	2	2W	3	3W	4	5	21	21/12	21W	22	22/12	25	203.000	203.100	203.120	203.200	203.220	203.300	204.000	204.020	204.100	204.200	204.220	204.300		
PAGE	177	177	177	177	181	181	181	181	181	181	181	181	181	182	182	182	182	182	182	179	179	179	179	179	179	179	179	179	179	179	179	179	179

DEVICES																																							
Contact thermostat	X	X	X	X																																			
Frost protection thermostat					X	X	X	X	X	X	X	X	X	X	X	X	X	X	X	X	X	X	X	X	X	X	X	X	X	X	X	X	X	X	X	X	X	X	X

CAPILLARY LENGTH																																										
Capillary 1,800 mm																																							X	X		
Capillary 3,000 mm																																								X	X	
Capillary 6,000 mm										X		X	X	X																											X	X
Capillary 12,000 mm										X																																X

OUTPUT																																									
Microswitch (potential-free changeover contact)	X	X	X	X	X	X	X	X	X	X	X	X	X	X	X	X	X	X	X	X	X	X	X	X	X	X	X	X	X	X	X	X	X	X	X	X	X	X	X	X	X

CONTROL RANGE																																													
-10 to +12 °C																																													
-10 to +15 °C																																												X	X
0 to 60 °C																																													
30 to 90 °C	X	X																																											

SWITCHING POWER																																															
15 (8) A, 24-250 V~																																															
16 (2) A, 24-250 V~	X	X	X	X																																											
NC contact:																																															
16 (2.5) A at 230 V~																																															
NO contact STW:																																															
6.3 (2.5) A at 230 V~																																															
NO contact STB:																																															
2.0 (0.4) A at 230 V~																																															

SUPPLY VOLTAGE																																												
none	X	X	X	X	X	X	X	X	X	X	X	X	X	X	X	X	X	X	X	X	X	X	X	X	X	X	X	X	X	X	X	X	X	X	X	X	X	X	X	X	X	X	X	X

DEGREE OF PROTECTION																																														
IP20	X	X	X	X																																										
IP40																																														
IP65																																														

MISCELLANEOUS																																														
Type testing by TÜV in accordance with DIN EN 14597																																														
Temperature controller	X	X																																												
Temperature monitor	X		X	X	X	X																																								
Temperature limiter																																														
Safety temperature limiter																																														
Safety temperature monitor																																														
external setting	X	X																																												
internal setting		X																																												



PLANT ENGINEERING OVERVIEW 5

ELECTRONIC TEMPERATURE CONTROLLERS, DIGITAL CONTROLLERS / DISPLAYS

TYPE	ITR										ETR		
	79.402	79.404	79.405	79.408	79.503	79.504	79.508	79.600	79.804	77.008-5	77.009-5		
PAGE	192	192	192	192	192	192	192	192	192	194	194		

DEVICES

Standard or top-hat rail controllers	x	x	x	x	x	x	x	x	x		
Universal controller										x	x

CONTROL RANGE

-50 to +50 °C											x
-35 to +15 °C	x										
-10 to +40 °C				x			x				
0 to 11 °C					x						
0 to 60 °C		x				x			x		
0 to 100 °C											x
5 to 30 °C								2			
35 to 95 °C			x								

SWITCHING POWER

10 (3) A, 250 V~, make contact	x	x	x	x	x	x	x	x	x		
5 (1.5) A / 250 V~, break contact	x	x	x	x	x	x	x	x	x		
10 (3) A, 250 V~, heating contact										x	x
5 (1) A, 250 V~, cooling contact										x	x

DEGREE OF PROTECTION

IP20	x	x	x	x	x	x	x	x	x		
IP65										x	x

MISCELLANEOUS

Temperature controller	x	x	x	x	x	x	x	x	x		
Temperature monitor										x	x
internal setting										x	x
LED heating (red)	x	x	x	x	x					x	x
LED cooling (green)						x	x				
230 V~, 50 Hz	x	x	x	x	x	x	x	x	x	x	x



PLANT ENGINEERING OVERVIEW 6

FLOW MONITORS AND PRESSURE SWITCHES, FLOW AND PRESSURE MONITORING

TYPE	JSL-		JDW-		JDL-				WSERD-		JSF-				JSW-		JPS-									
	1E	3/3Z	5/5Z	10	111	112	115	116	116A	134.446	134.446	3E	4E	1E	1RE	2E	2RE	1/2	3/4	1	1	3	3B	4	13	
PAGE	197	198	198	198	198	198	198	198	198	200	200	201	201	201	201	201	201	204	204	204	206	206	206	206	206	206

DEVICES

Wind indicator relays	x																								
Differential pressure switch		x	x	x	x	x	x	x	x																
Airflow monitors										x	x														
Flow monitors												x	x	x	x	x	x	x	x	x					
Pressure switch switches																							x	x	x

SENSOR ELEMENT

wind indicator	x																								
Sensor rod (hot film anemometer)										x	x														
Pressure sensor (membrane)		x	x	x	x	x	x	x	x													x	x	x	x
Paddle												x	x	x	x	x	x	x	x	x					

OUTPUT

Microswitch (potential-free changeover contact)	x	x	x	x	x	x	x	x	x			x	x	x	x	x	x	x	x	x	x	x	x	x
Relays (potential-free changeover contact)										x	x													

SWITCHING RANGE

0.2–10 m/s												x	x											
1–8 m/s switch-off value	x																							
Dependent on the tube diameter														x	x	x	x	x	x	x	x			
20–300 Pa							x																	
20–330 Pa			x																					
30–500 Pa				x																				
40–600 Pa								x																
100–1,000 Pa									x															
250–5,000 Pa										x	x													
400–1,600 Pa												x	x											
0.3–4.0 bar																							x	x
0.3–6.0 bar																								x

SWITCHING POWER

15 (8) A, 24–250 V~	x											x	x	x	x	x	x	x						
10 (3) A, 24–250 V~												x	x											
1.5 (0.4) A, 12–250 V~			x	x	x																			
1 (0.2) A, 12–24 V AC/DC			x	x	x	x	x	x	x	x														
5 (1) A, 12–250 V~							x	x	x	x	x													
5 (1.5) A, 24–230 V~																						x	x	x
2 A (2), 230 V~																								x

OPERATING VOLTAGE

none	x	x	x	x	x	x	x	x	x															
230 V~, 50 Hz												x	x											
24 V~, 50 Hz												x	x											

DEGREE OF PROTECTION

IP10																								
IP54			x	x	x	x	x	x	x	x														
IP65	x													x	x	x	x	x	x	x	x	x	x	x

MISCELLANEOUS

Type tested by the TÜV according to the current 100 to 6																								
external setting											x													
internal setting	x	x	x	x	x	x	x	x	x															

FEATURING A BRAND NEW DESIGN

THERMOSTATS FOR PLANT ENGINEERING

We proudly present our latest RTKSA thermostats, versatile enough to suit a wide range of applications including greenhouses, industrial buildings, and warehouses. These are more than just thermostats; they are multifunctional solutions engineered for effective temperature control in various fields. Their standout feature is the compatibility with different accessories, allowing them to serve various roles, from boiler and ventilation to contact thermostats. alre's new thermostats offer a flexible, multi-use tool for diverse temperature control requirements.



COMBINATIONS WITH ACCESSORIES



**UNIVERSAL
CONTROLLER**



**UNIVERSAL
DOUBLE CONTROLLER**



**PLANT ROOM CONT-
ROLLER**



**FROST PROTECTION
CONTROLLER**

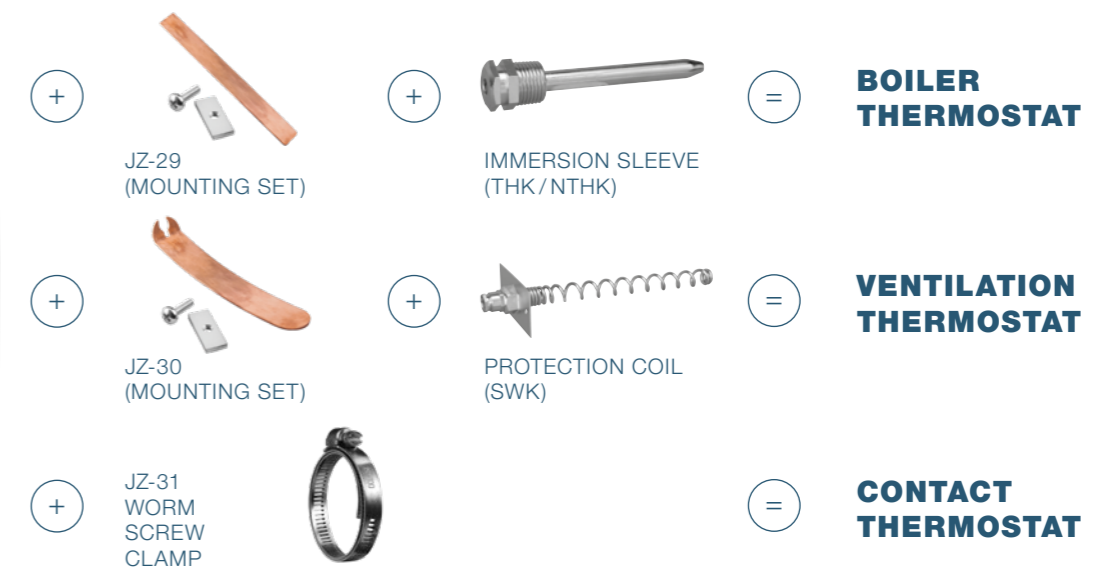

FOR DOUBLE THERMOSTATS, USE THE JZ-30 MOUNTING SET.

See page 166 onwards for more information on universal thermostats

PLANT ROOM THERMOSTAT RTKSA

CAPILLARY SYSTEM – EXTERNAL SENSORS

PLANT ROOM THERMOSTAT RTKSA

CAPILLARY SYSTEM – EXTERNAL SENSORS

TECHNICAL DATA

Colour: anthracite grey (similar to RAL 7016), front side transparent

Sensor material: V4A

Max. sensor temperature: Top scale value +15%

Max. head temperature: 50 °C

Permissible atmospheric humidity: Max. 95% rel. humidity, non-condensing

Operating voltage: none

Max. switching current: **NC contact:** 16 (2.5) A at 230 VAC +10%
0.25 A at 230 VDC +10%
NO contact: 6.3 (2.5) A at 230 VAC +10%
0.25 A at 230 VDC +10%

Min. switching current: Min. 100 mA at 24 V (AC/DC)

Max. switching voltage: 230 VAC 50/60 Hz, 230 VDC

Min. switching voltage: 24 VAC/50 Hz, 24 VDC

Switching element: microswitch

Switching contact: toggler, potential-free

Control function: heating or cooling

Hysteresis: 1.3 K

Electrical connection: Push-in terminals

Mounting / attachment: wall mounting

Protection class: I

Protection rating: IP54 (optionally IP65)

Safety and EMC: In accordance with DIN EN 60730 (VDE 0631)

Sensor: liquid-filled capillary

General features: scale: degrees Celsius

APPLICATION

RTKSA plant room thermostats were specially developed for use in industrial halls, exhibition halls, air halls and greenhouses. When used as a frost protection controller, the higher tolerances at the end of the scale must be observed.

Type testing by TÜV in accordance with DIN EN 14597



TYPE	ITEM NO.	CONTROL RANGE	HYSTERESIS	FEATURES	EURO/PG
RTKSA-100.010	KA010000	-10 to +40 °C	1.3 K	TR, external setting	106.90/II
RTKSA-101.010	KA010100	-10 to +40 °C	1.3 K	TW, internal setting	106.90/II
RTKSA-100.110	KA010001	0 to +50 °C	1.3 K	TR, external setting	107.40/II
RTKSA-101.110	KA010101	0 to +50 °C	1.3 K	TW, internal setting	106.90/II

TR = temperature controller, TW = temperature monitor

ACCESSORIES	ITEM NO.	FEATURES	EURO/PG
JZ-33	KA999904	RTKSA seal set, protection rating: IP54	18.50/II

TYPE COMPARISON (OLD / NEW TYPE)

OLD ALRE TYPES	CONTROL RANGE	HYSTERESIS	NEW ALRE TYPES	CONTROL RANGE	HYSTERESIS
JET-40	0 to +35 °C	1 K	RTKSA-100.010	-10 to +40 °C	1.3 K
JET-40F	0 to +35 °C	1 K	RTKSA-101.010	-10 to +40 °C	1.3 K
JET-41	0 to +70 °C	2 K	RTKSA-100.110	0 to +50 °C	1.3 K
JET-41F	0 to +70 °C	2 K	RTKSA-101.110	0 to +50 °C	1.3 K

TR = temperature controller, TW = temperature monitor

ILLUSTRATIONS

RTKSA with internal setting



RTKSA

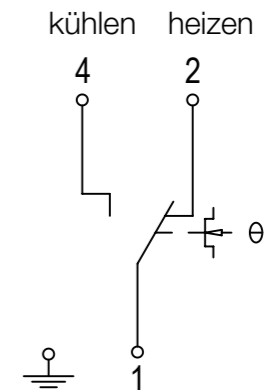

RTKSA-100.010 / RTKSA-100.110

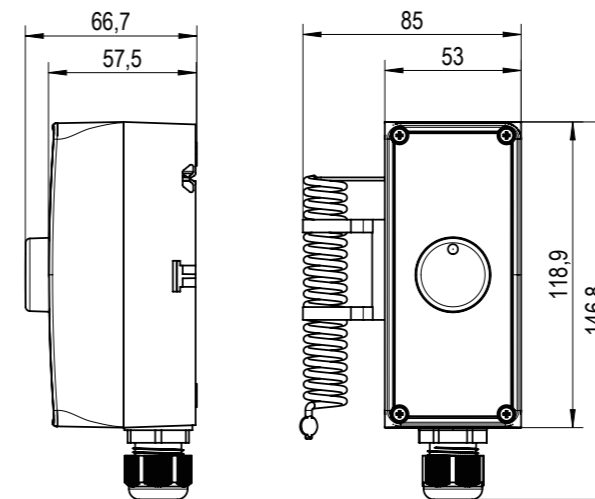

RTKSA-101.010 / RTKSA-101.110

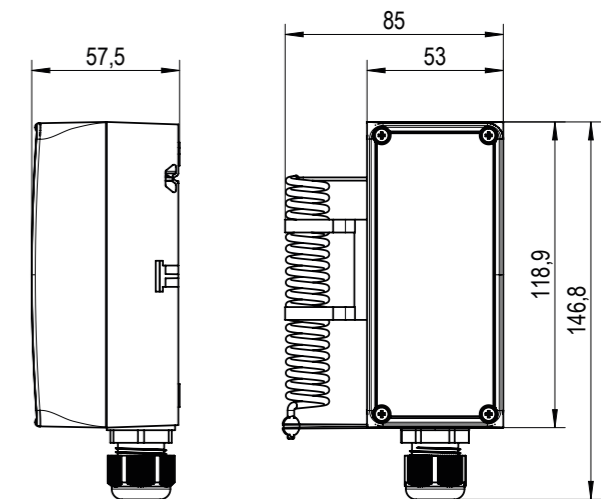

Scan the QR code now and watch the 'New thermostats in plant engineering' product film. More information at a glance.





PLANT ROOM DOUBLE THERMOSTAT RTKSA

CAPILLARY SYSTEM – EXTERNAL SENSORS – 2 SEPARATE SETTING RANGES



TECHNICAL DATA

Colour: anthracite grey (similar to RAL 7016), front side transparent

Sensor material: V4A

Max. sensor temperature: Top scale value +15%

Max. head temperature: 50 °C

Permissible atmospheric humidity: Max. 95% rel. humidity, non-condensing

Operating voltage: none

Max. switching current: **NC contact:** 16 (2.5) A at 230 VAC +10%
0.25 A at 230 VDC +10%
NO contact: 6.3 (2.5) A at 230 VAC +10%
0.25 A at 230 VDC +10%

Min. switching current: Min. 100 mA at 24 V (AC/DC)

Max. switching voltage: 230 VAC 50 / 60 Hz, 230 VDC

Min. switching voltage: 24 VAC / 50 Hz, 24 VDC

Switching element: microswitch

Switching contact: 2 x togglers, potential-free

Control function: heating or cooling, heating and cooling

Hysteresis: 1.3 K

Electrical connection: Push-in terminals

Mounting / attachment: wall mounting

Protection class: I

Protection rating: IP54 (optionally IP65)

Safety and EMC: In accordance with DIN EN 60730 (VDE 0631)

Sensor: liquid-filled capillary

General features: scale: degrees Celsius

APPLICATION

RTKSA plant room thermostats were specially developed for use in industrial halls, exhibition halls, air halls and greenhouses. When used as a frost protection controller, the higher tolerances at the end of the scale must be observed.

2 separate setting ranges, heating and / or cooling.

Type testing by TÜV in accordance with DIN EN 14597



TYPE	ITEM NO.	1. CONTROL RANGE	2. CONTROL RANGE	FEATURES	EURO/PG
RTKSA-114.110	KA011100	0 to +50 °C (TW, internal)	0 to +50 °C (TW, internal)	2 x internal setting	181.00/II
RTKSA-114.010	KA011101	-10 to +40 °C (TW, internal)	-10 to +40 °C (TW, internal)	2 x internal setting	181.00/II

TW = Temperature monitor

ACCESSORIES	ITEM NO.	FEATURES	EURO/PG
JZ-33	KA999904	Seal set RTKSA, 2 units necessary for double thermostats, protection rating: IP54	18.50/II

TYPE COMPARISON (OLD / NEW TYPE)

OLD ALRE TYPES	CONTROL RANGE	HYSTERESIS	NEW ALRE TYPES	CONTROL RANGE	HYSTERESIS
JET-30	10 to 45 °C (external) TR 0 to 35 °C (internal) TW	approx. 1 K	RTKSA-114.110	0 to +50 °C (internal) TW 0 to +50 °C (internal) TW	1.3 K
JET-31	10 to +45 °C (internal) TW 0 to +35 °C (internal) TW	approx. 1 K			

TR = temperature controller, TW = temperature monitor

ILLUSTRATIONS

RTKSA

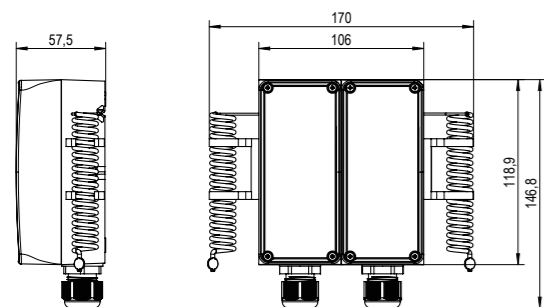

RTKSA (2x)

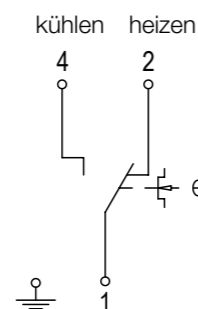

Scan the QR code now and watch the 'New thermostats in plant engineering' product film. More information at a glance.



WET ROOM THERMOSTAT PTR 40

BIMETAL



TECHNICAL DATA

Housing colour: grey (lower part like RAL 7016, upper part like RAL 7035)

Ambient temperature: -20 to +60 °C

Permissible atmospheric humidity: Max. 95% rel. humidity, non-condensing

Operating voltage: 230 V AC, 50 Hz

Max. switching current: heating (terminal 3) 10 (4) A, cooling (terminal 1) 5 (2) A

Max. switching voltage: 230 V AC, 50 Hz

Min. switching voltage: 230 V AC, 50 Hz

Switching element: bimetallic contact

Control range: -20 to +30 °C

Hysteresis: approx. 2 K at a temperature change of max. 4 K/h

Electrical connection: screw-type terminals 0.12 mm²–2.5 mm²

Mounting / attachment: wall mounting

Protection rating: IP65

Protection class: II

Safety and EMC: according to DIN EN 60730

Sensor: bimetal

Function type: TW (temperature monitor)

General features: thermal feedback, internal setting, scale: degrees Celsius

APPLICATION

Control and monitoring of temperatures of certain open spaces, for example, driveways or damp rooms (greenhouses, sheds, warehouses and basements, garages, etc.).

TYPE	ITEM NO.	FEATURES	EURO/PG
PTR 40.000	A201410	switching contact changeover switch (toggler), control function heating or cooling, viewing window	96.20/II

ILLUSTRATIONS

PTR 40

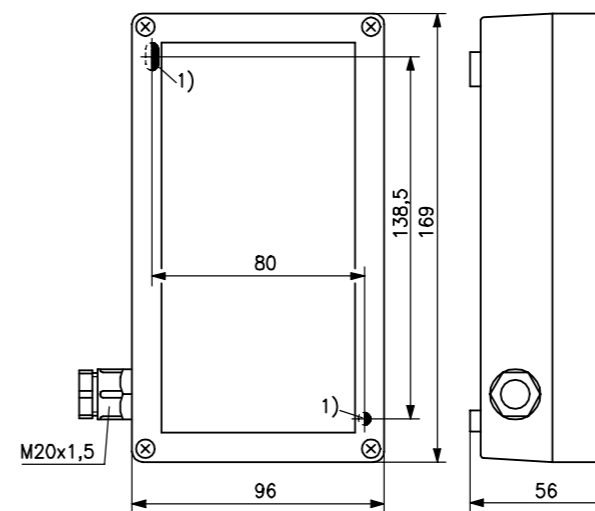

PTR 40 ...

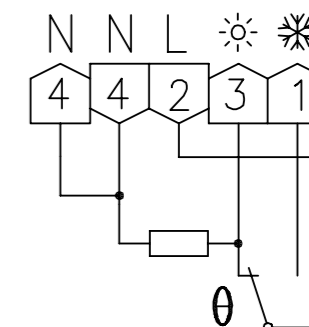



UNIVERSAL CAPILLARY THERMOSTAT RTKSA CAPILLARY SYSTEM – TÜV-TESTED



TECHNICAL DATA

Colour:	anthracite grey (similar to RAL 7016), front side transparent
Sensor material:	Cu
Sensor length:	2 m
Max. sensor temperature:	Top scale value +15%
Max. head temperature:	80 °C
Permissible atmospheric humidity:	Max. 95% rel. humidity, non-condensing
Operating voltage:	none
Max. switching current:	NC contact: 16 (2.5) A at 230 VAC +10% 0.25 A at 230 VDC +10% NO contact TR/TW/STW: 6.3 (2.5) A at 230 VAC +10% 0.25 A at 230 VDC +10% NO contact TB: 2.0 (0.4) A at 230 VAC +10% 0.25 A at 230 VDC +10%
Min. switching current:	Min. 100 mA at 24 V (AC/DC)
Max. switching voltage:	230 VAC 50/60 Hz, 230 VDC
Min. switching voltage:	24 VAC/50 Hz, 24 VDC
Switching element:	microswitch
Switching contact:	toggler, potential-free
Control range:	heating or cooling
Electrical connection:	Push-in terminals
Mounting / attachment:	Wall mounting or with optional process connection (immersion sleeve, protection coil or mounting set JZ-31 for pipe mounting)
Protection class:	I
Protection rating:	RTKSA-xxx.x0x IP40, RTKSA-xxx.x1x IP54, optional IP65
Safety and EMC:	In accordance with DIN EN 60730 (VDE 0631)
Sensor:	liquid-filled capillary
General features:	scale: degrees Celsius

APPLICATION

This series of devices was specially developed for use in heating technology; in boiler systems or storage tanks; district heating transfer stations and heat transfer systems; in ventilation technology to monitor supply air or as limiters for electrical heating coils, as well as for controlling and monitoring temperatures in pipelines and tanks.

Immersion sleeves, protection coils and mounting sets are not included in the scope of delivery. The JZ-29 mounting set must be used in conjunction with immersion sleeves or protection coils. When used as contact controller (pipe mounting), mounting set JZ-31 must be used, except with models RTKSA-000 100 and RTKSA-001 100.

Type testing by TÜV in accordance with DIN EN 14597



TYPE	ITEM NO.	CONTROL RANGE	HYSTERESIS	SENSOR Ø X L	FEATURES	EURO/PG
RTKSA-000.100	KA000000	0 to 50 °C	1.3 K	6 x 175 mm	TR, external setting	72.90/II
RTKSA-000.200	KA000001	0 to 120 °C	3 K	6 x 87 mm	TR, external setting	73.80/II
RTKSA-000.300	KA000002	20 to 150 °C	9.1 K	6 x 56 mm	TR, external setting	73.80/II
RTKSA-001.100	KA000100	0 to 50 °C	1.3 K	6 x 175 mm	TW, internal setting	76.50/II
RTKSA-001.200	KA000101	0 to 120 °C	3 K	6 x 87 mm	TW, internal setting	76.50/II
RTKSA-001.300	KA000102	20 to 150 °C	9.1 K	6 x 56 mm	TW, internal setting	76.50/II
RTKSA-001.301	KA000103	20 to 150 °C	3.3 K	6 x 82 mm	TW, internal setting	76.50/II
RTKSA-002.310	KA000201	20 to 150 °C	-10 to -15K*	6 x 55 mm	TB, internal setting, external reset	89.20/II
RTKSA-002.410	KA000200	30 to 110 °C	-10 to -15K*	6 x 72 mm	TB, internal setting, external reset	85.00/II
RTKSA-003.310	KA000300	20 to 150 °C	-10 to -15K*	6 x 55 mm	STB, internal setting, external reset	103.90/II
RTKSA-004.310	KA000400	20 to 150 °C	-10 K	6 x 55 mm	STW, internal setting	95.20/II

TR = temperature controller, TW = temperature monitor, TB = temperature limiter, STB = safety temperature limiter, STW = safety temperature monitor
* Manual reset after cooling down by 10–15 K (depending on configured setpoint)



UNIVERSAL CAPILLARY THERMOSTAT RTKSA CAPILLARY SYSTEM – TÜV-TESTED

ACCESSORIES	ITEM NO.	LENGTH OF	MATERIAL	DIAMETER IxA**	FEATURES	EURO/PG
THK-2-100	KA969901	100 mm	nickel-plated brass	7.5 x 10 mm	Immersion sleeve	22.50/II
THK-2-120	KA969902	120 mm	nickel-plated brass	7.5 x 10 mm	Immersion sleeve	25.70/II
THK-2-200	KA969903	200 mm	nickel-plated brass	7.5 x 10 mm	Immersion sleeve	26.40/II
THK-2-280	KA969904	280 mm	nickel-plated brass	7.5 x 10 mm	Immersion sleeve	32.10/II
THK-2-600	KA969905	600 mm	nickel-plated brass	7.5 x 10 mm	Immersion sleeve	51.10/II
NTHK-2-100	KA969906	100 mm	V4A (1.4571)	7.5 x 10 mm	Immersion sleeve	61.20/II
NTHK-2-120	KA969907	120 mm	V4A (1.4571)	7.5 x 10 mm	Immersion sleeve	62.10/II
NTHK-2-200	KA969908	200 mm	V4A (1.4571)	7.5 x 10 mm	Immersion sleeve	63.30/II
NTHK-2-280	KA969909	280 mm	V4A (1.4571)	7.5 x 10 mm	Immersion sleeve	64.80/II
THK-2-100 x 17	KA979901	100 mm	nickel-plated brass	14.8 x 17 mm	Immersion sleeve	32.60/II
THK-2-200 x 17	KA979902	200 mm	nickel-plated brass	14.8 x 17 mm	Immersion sleeve	43.80/II
NTHK-2-100 x 17	KA979903	100 mm	V4 A (1.4571)	14.8 x 17 mm	Immersion sleeve	63.70/II
NTHK-2-200 x 17	KA979904	200 mm	V4 A (1.4571)	14.8 x 17 mm	Immersion sleeve	66.00/II
SWK-2-100	KA989901	100 mm	steel, nickel-plated	10.5 x 17 mm	Protection coil with flange plate	20.80/II
SWK-2-120	KA989902	120 mm	steel, nickel-plated	10.5 x 17 mm	Protection coil with flange plate	25.70/II
SWK-2-200	KA989903	200 mm	steel, nickel-plated	10.5 x 17 mm	Protection coil with flange plate	26.40/II
SWK-2-280	KA989904	280 mm	steel, nickel-plated	10.5 x 17 mm	Protection coil with flange plate	32.10/II

** I = minimum inner diameter / A = nominal outer diameter
See page 170 for pictures and dimension diagrams for immersion sleeves/protection coils

ACCESSORIES	ITEM NO.	FEATURES	EURO/PG
JZ-29	KA999901	Mounting set RTKSA for THK/NTHK/SWK individual controllers	4.30/II
JZ-31	KA999903	Mounting set RTKSA for pipe mounting contact controller (worm screw clamp)	5.30/II
JZ-33	KA999904	RTKSA seal set, protection rating: IP54	18.00/II

TYPE COMPARISON (OLD / NEW TYPE)

OLD ALRE TYPES	CONTROL RANGE	HYSTERESIS	NEW ALRE TYPES	CONTROL RANGE	HYSTERESIS	ACCESSORIES
KR 80.312	fixed at 100 °C	-20 K	RTKSA-003.310	20 to 150 °C	-10 K	THK-2-100 + JZ-29
LR 80.312	fixed at 100 °C	-20 K				SWK-2-100 + JZ-29
KR 80.318	fixed at 100 °C	-20 K				THK-2-200 + JZ-29
LR 80.318	fixed at 100 °C	-20 K				SWK-2-200 + JZ-29
KR 80.309	fixed at 75 °C	-20 K				THK-2-100 + JZ-29
LR 80.309	fixed at 75 °C	-20 K				SWK-2-100 + JZ-29
KR 80.310	fixed at 75 °C	-20 K				THK-2-200 + JZ-29
LR 80.310	fixed at 75 °C	-20 K				SWK-2-200 + JZ-29
KR 80.206	30 to 65 °C	-8 K	RTKSA-002.410	30 to 110 °C	-10 K	THK-2-100 + JZ-29
KR 80.206 IP54	30 to 65 °C	-8 K				THK-2-100 + JZ-29
KR 80.207	60 to 95 °C	-8 K				THK-2-100 + JZ-29
LR 80.207	60 to 95 °C	-8 K				SWK-2-100 + JZ-29
KR 80.208	85 to 120 °C	-8 K	RTKSA-002.310	20 to 150 °C	-10 K	THK-2-100 + JZ-29
KR 80.202	95 to 130 °C	-8 K				THK-2-100 + JZ-29
KR 80.203	95 to 130 °C	-8 K				THK-2-200 + JZ-29
LR 80.203	95 to 130 °C	-8 K				SWK-2-200 + JZ-29
KR 80.203 IP54	95 to 130 °C	-8 K				THK-2-200 + JZ-29

UNIVERSAL CAPILLARY THERMOSTAT RTKSA CAPILLARY SYSTEM – TÜV-TESTED

TYPE COMPARISON (OLD / NEW TYPE)

OLD ALRE TYPES	CONTROL RANGE	HYSTERESIS	NEW ALRE TYPES	CONTROL RANGE	HYSTERESIS	ACCESSORIES
WR 81.029-1	0 to 35 °C	0.5–1 K	RTKSA-000.100	0 to 50 °C	1.3 K	-
KR 80.003-1	0 to 35 °C	1 K				THK-2-200 + JZ-29
LR 80.003-1	0 to 35 °C	1 K				SWK-2-200
WR 81.009-2	0 to 70 °C	1–2 K	RTKSA-000.200	0 to 120 °C	3 K	-
KR 80.035-2	0 to 70 °C	2 K				THK-2-100 + JZ-29
KR 80.027-5	0 to 70 °C	5 K				THK-2-100 + JZ-29
LR 80.027-5	0 to 70 °C	5 K				SWK-2-100 + JZ-29
LR 80.035-2	0 to 70 °C	2 K				SWK-2-100 + JZ-29
KR 80.028-2	0 to 70 °C	2 K				THK-2-200 + JZ-29
LR 80.028-2	0 to 70 °C	2 K				SWK-2-200 + JZ-29
KR 80.029-2	0 to 70 °C	2 K				THK-2-280 + JZ-29
KR 80.029-2 V4A	0 to 70 °C	3 K				NTHK-2-280 + JZ-29
LR 80.029-2	0 to 70 °C	2 K				SWK-2-280 + JZ-29
KR 80.011-1 V4A	10 to 45 °C	1 K	RTKSA-000.200	0 to 120 °C	3 K	NTHK-2-120 + JZ-29
KR 80.009-1 V4A	10 to 45 °C	1 K				NTHK-2-200 + JZ-29
KR 80.000-5	35 to 95 °C	5 K				THK-2-100 + JZ-29
KR 80.001-5	35 to 95 °C	5 K				THK-2-200 + JZ-29
KR 80.001-5 V4A	35 to 95 °C	5 K				NTHK-2-200 + JZ-29
KR 80.008-8	40 to 110 °C	8 K				THK-2-100 + JZ-29
KR 80.006-8	50 to 130 °C	8 K				THK-2-100 + JZ-29
WR 81.101-1	0 to 35 °C	0.5–1 K	RTKSA-001.100	0 to 50 °C	1.3 K	-
WR 81.129-1	0 to 35 °C	0.5–1 K				-
KR 80.108-1	0 to 35 °C	1 K				-
LR 80.108-1	0 to 35 °C	1 K				-
KR 80.109-1	0 to 35 °C	1 K				THK-2-200 + JZ-29
WR 81.115-5	0 to 70 °C	4 K	RTKSA-001.200	0 to 120 °C	3 K	JZ-31
WR 81.109-2	0 to 70 °C	1–2 K				-
KR 80.116-2	0 to 70 °C	2 K				THK-2-100 + JZ-29
LR 80.116-2	0 to 70 °C	2 K				SWK-2-100 + JZ-29
KR 80.111-3	0 to 80 °C	1 K				THK-2-100 + JZ-29
KR 80.120-1	10 to 45 °C	1 K				THK-2-200 + JZ-29
LR 80.120-1	10 to 45 °C	1 K				SWK-2-200 + JZ-29
KR 80.100-5	35 to 95 °C	5 K				THK-2-100 + JZ-29
KR 80.100-5 IP54	35 to 95 °C	5 K				NTHK-2-100 + JZ-29
KR 80.101-5	35 to 95 °C	5 K				THK-2-200 + JZ-29
LR 80.101-5	35 to 95 °C	5 K	SWK-2-200 + JZ-29			
KR 80.124-5	35 to 95 °C	5 K	THK-2-280 + JZ-29			
KR 80.112-5	35 to 95 °C	8 K	RTKSA-001.300	20 to 150 °C	3.3 K	THK-2-600 + JZ-29
KR 80.102-8	40 to 110 °C	8 K				THK-2-100 + JZ-29
KR 80.103-8	40 to 110 °C	8 K				THK-2-200 + JZ-29
WR 81.117-5	50 to 130 °C	4 K				JZ-31
KR 80.106-8	50 to 130 °C	8 K				THK-2-100 + JZ-29

UNIVERSAL CAPILLARY THERMOSTAT RTKSA CAPILLARY SYSTEM – TÜV-TESTED

ILLUSTRATIONS

RTKSA with internal setting



RTKSA with internal setting and external reset



RTKSA TR

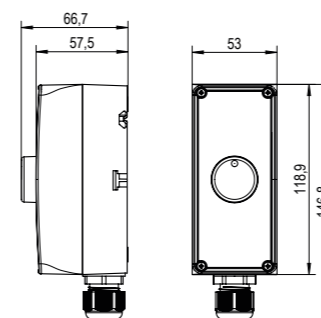

RTKSA TB / STB

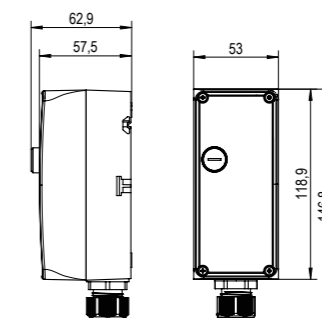

RTKSA TW / STW

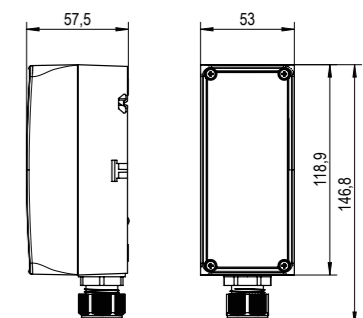

RTKSA-000.xxx / RTKSA-001.xxx / RTKSA-004.xxx

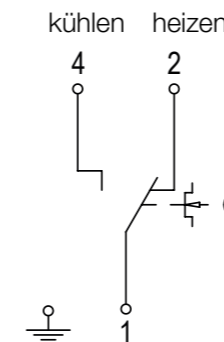

RTKSA-002.xxx / RTKSA-003.xxx

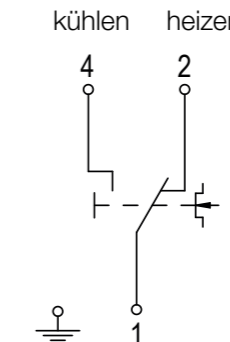

Scan the QR code now and watch the 'New thermostats in plant engineering' product film. More information at a glance.

ACCESSORIES

JZ-29



JZ-31



JZ-33





UNIVERSAL CAPILLARY DOUBLE THERMOSTAT RTKSA CAPILLARY SYSTEM – TÜV-TESTED

**TECHNICAL DATA**

Colour:	anthracite grey (similar to RAL 7016), front side transparent
Sensor material:	Cu
Sensor length:	2 m
Max. sensor temperature:	Top scale value +15%
Max. head temperature:	80 °C
Permissible atmospheric humidity:	Max. 95% rel. humidity, non-condensing
Operating voltage:	none
Max. switching current:	NC contact: 16 (2.5) A at 230 VAC +10% 0.25 A at 230 VDC +10% NO contact TR/TW: 6.3 (2.5) A at 230 VAC +10% 0.25 A at 230 VDC +10% NO contact TB/STB: 2.0 (0.4) A at 230 VAC +10% 0.25 A at 230 VDC +10%
Min. switching current:	Min. 100 mA at 24 V (AC/DC)
Max. switching voltage:	230 VAC 50/60 Hz, 230 VDC
Min. switching voltage:	24 VAC/50 Hz, 24 VDC
Switching element:	microswitch
Switching contact:	2 x togglers, potential-free
Control range:	heating or cooling
Electrical connection:	Push-in terminals
Mounting / attachment:	Wall mounting or with optional process connection (immersion sleeve or protection coil)
Protection class:	I
Protection rating:	RTKSA-xxx.x0x IP40 RTKSA-xxx.x1x IP54 IP65 (optional)
Safety and EMC:	In accordance with DIN EN 60730 (VDE 0631)
Sensor:	liquid-filled capillary
General features:	scale: degrees Celsius

APPLICATION

This series of devices was specially developed for use in heating technology; in boiler systems or storage tanks; district heating transfer stations and heat transfer systems; in ventilation technology to monitor supply air or as limiters for electrical heating coils, as well as for controlling and monitoring temperatures in pipelines and tanks.

Immersion sleeves, protection coils and mounting set JZ-31 for pipe mounting are not included in the scope of delivery.

Accessory JZ-30 must be used in conjunction with immersion sleeves.

Type testing by TÜV in accordance with DIN EN 14597



TYPE	ITEM NO.	CONTROL RANGE	HYSTERESIS	SENSOR Ø X L	FEATURES	EURO/PG
RTKSA-010.200	KA001000	TR: 0 to 120 °C STB: 70 to 130 °C	TR: 3 K STB: -10 to -15 K*	6 x 87 mm 6 x 66 mm	TR (external setting), STB (internal setting/ external reset)	151.30/II
RTKSA-013.210	KA001200	TW: 0 to 120 °C TB: 20 to 150 °C	TW: 3 K TB: -10 to -15 K*	6 x 87 mm 6 x 55 mm	TW (internal setting) TB (internal setting/ external reset)	196.70/II
RTKSA-014.210	KA001100	TW: 0 to 120 °C TW: 0 to 120 °C	TW: 3 K TW: 3 K	6 x 87 mm 6 x 87 mm	2x TW (internal setting)	151.30/II

TR = temperature controller, TW = temperature monitor, TB = temperature limiter, STB = safety temperature limiter

* Manual reset after cooling down by 10–15 K (depending on configured setpoint)

ACCESSORIES	ITEM NO.	LENGTH	MATERIAL	DIAMETER I X A**	FEATURES	EURO/PG
THK-2-100x17	KA979901	100 mm	nickel-plated brass	14.8 x 17 mm	Immersion sleeve	32.60/II
THK-2-200x17	KA979902	200 mm	nickel-plated brass	14.8 x 17 mm	Immersion sleeve	43.80/II
NTHK-2-100x17	KA979903	100 mm	V4A (1.4571)	14.8 x 17 mm	Immersion sleeve	63.70/II
NTHK-2-200x17	KA979904	200 mm	V4A (1.4571)	14.8 x 17 mm	Immersion sleeve	66.00/II
SWK-2-100	KA989901	100 mm	steel, nickel-plated	10.5 x 17 mm	Protection coil with flange plate	20.80/II
SWK-2-200	KA989903	200 mm	steel, nickel-plated	10.5 x 17 mm	Protection coil with flange plate	26.40/II

** I = minimum inner diameter / A = nominal outer diameter

See page 229 for pictures and dimension diagrams for immersion sleeves/protection coils



UNIVERSAL CAPILLARY DOUBLE THERMOSTAT RTKSA CAPILLARY SYSTEM – TÜV-TESTED

ACCESSORIES	ITEM NO.	FEATURES	EURO/PG
JZ-30	KA999902	Mounting set RTKSA for THK/NTHK/SWK double controllers	7.10/II
JZ-33	KA999904	Seal set RTKSA, 2 units necessary for double thermostats, protection rating: IP54	18.50/II

TYPE COMPARISON (OLD / NEW TYPE)

OLD ALRE TYPES	CONTROL RANGE	HYSTERESIS	NEW ALRE TYPES	CONTROL RANGE	HYSTERESIS	ACCESSORIES
KR 85.100-5	TR 35 to 95 °C TW 35 to 95 °C	5 K 5 K	RTKSA-014.210	TW: 0 to 120 °C TW: 0 to 120 °C	3 K 3 K	THK-2-100x17 + JZ-30
KR 85.406-2	TW 0 to 70 °C TW 0 to 70 °C	2 K 2 K				THK-2-100x17 + JZ-30
KR 85.101-5	TR 35 to 95 °C TW 35 to 95 °C	5 K 5 K				THK-2-200x17 + JZ-30
KR 85.102-5	TR 35 to 95 °C TW 50 to 130 °C	5 K 8 K				THK-2-100x17 + JZ-30
KR 85.109-2	TR 0 to 70 °C TW 0 to 70 °C	2 K 2 K				THK-2-100x17 + JZ-30
KR 85.400-5	TW 35 to 95 °C TW 35 to 95 °C	5 K 5 K				THK-2-100x17 + JZ-30
KR 85.401-5	TW 35 to 95 °C TW 35 to 95 °C	5 K 5 K				THK-2-200x17 + JZ-30
KR 85.315-5	TR 35 to 95 °C STB fixed at 100 °C	5 K -20 K				THK-2-200x17 + JZ-30
KR 85.311-2	TR 0 to 70 °C STB fixed at 75 °C	2 K -20 K				THK-2-100x17 + JZ-30
KR 85.312-2	TR 0 to 70 °C STB fixed at 75 °C	2 K -20 K				THK-2-200x17 + JZ-30
KR 85.314-5	TR 35 to 95 °C STB fixed at 100 °C	5 K -20 K	RTKSA-010.200	TR: 0 to 120 °C STB: 70 to 130 °C	3 K -10 to -15 K	THK-2-100x17 + JZ-30
LR 85.315-5	TR 35 to 95 °C STB fixed at 100 °C	5 K -20 K				SWK-2-200
LR 85.312-2	TR 0 to 70 °C STB fixed at 75 °C	2 K -20 K				SWK-2-200
KR 85.204-8	TR 50 to 130 °C TB 95 to 130 °C	8 K -8 K	RTKSA-013.210	TW: 0 to 120 °C TB: 20 to 150 °C	3 K -10 to -15 K	THK-2-100x17 + JZ-30
KR 85.230-5	TR 35 to 95 °C TB 95 to 110 °C	5 K 5 K				THK-2-100x17 + JZ-30
KR 85.207-5	TR 35 to 95 °C TB 85 to 120 °C	5 K -8 K				THK-2-200x17 + JZ-30

UNIVERSAL CAPILLARY DOUBLE THERMOSTAT RTKSA CAPILLARY SYSTEM – TÜV-TESTED

ILLUSTRATIONS

RTKSA-014.210

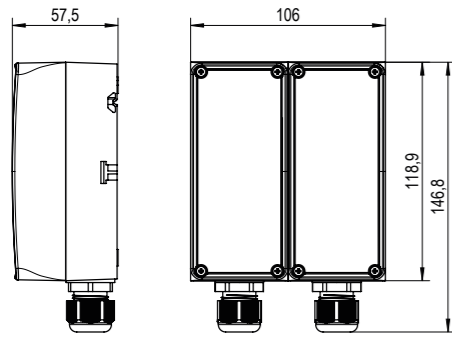

RTKSA-010.200

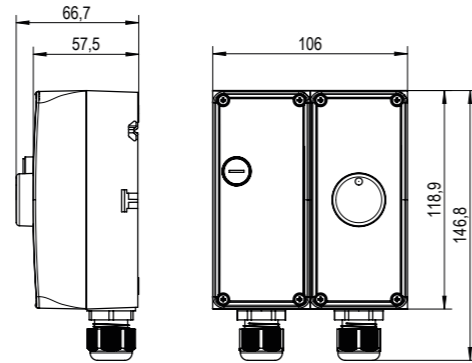

RTKSA-013.210

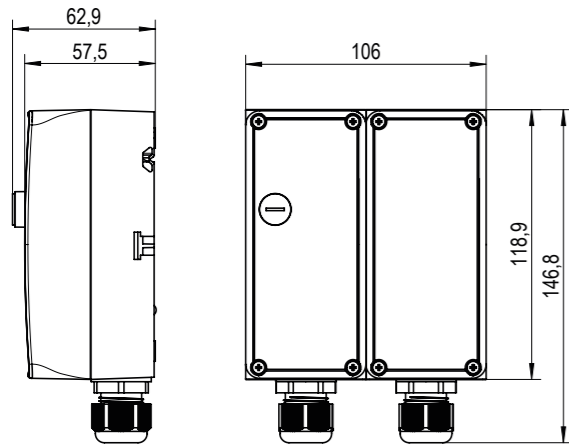

Scan the QR code now and watch the 'New thermostats in plant engineering' product film. More information at a glance.



RTKSA-010.200/RTKSA-013.210

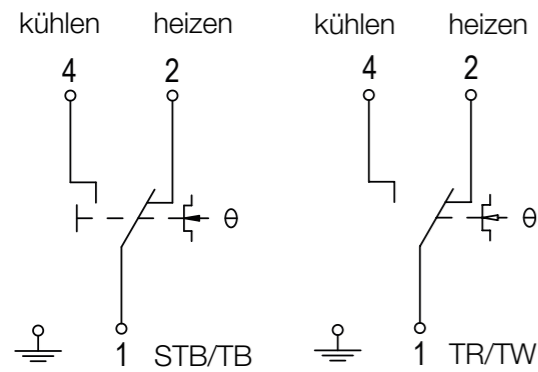

RTKSA-014.210

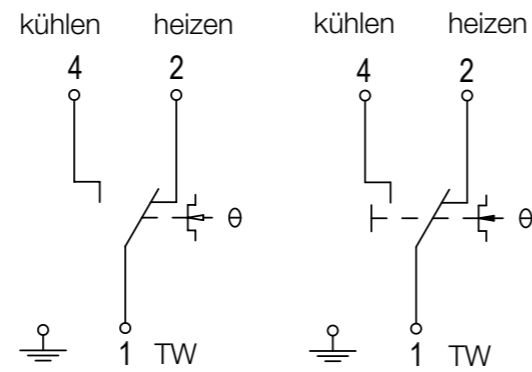

JZ-30



JZ-33



SINGLE-STAGE PLANT ROOM THERMOSTATS JET-110/-120 CAPILLARY SYSTEM – EXTERNAL SENSORS – CONFIGURABLE HYSTERESIS

TECHNICAL DATA

Colour: grey (lower part similar to RAL 7016, upper part similar to RAL 7035)
Permissible atmospheric humidity: Max. 95% rel. humidity, non-condensing
Operating voltage: none
Max. switching current: 10 (4) A
Min. switching current: 150 mA
Max. switching voltage: 230 V AC, 50 Hz
Min. switching voltage: 24 V AC, 50 Hz
Switching element: microswitch
Switching contact: toggler, potential-free
Control function: heating or cooling
Electrical connection: screw-type terminals
Mounting/attachment: wall mounting
Protection class: I
Protection rating: IP65
Safety and EMC: according to DIN EN 60730
Sensor: liquid-filled capillary
Sensor material: Cu
General features: scale: degrees Celsius

APPLICATION

Control or monitoring of the temperature in the industrial domain in a non-aggressive environment, for example, for controlling heating or cooling systems in greenhouses, industrial and sports halls, air-inflated domes, cold storage and refrigeration rooms.
 The JET-110 RF is particularly suitable as an external thermostat.
 For successor types for JET-4x and JET-4x F see page 162 (plant room thermostat RTKSA)



TYPE	ITEM NO.	CONTROL RANGE	MAX. SENSOR TEMPERATURE	HYSTERESIS (APPROX.)	AMBIENT TEMPERATURE	FEATURES	EURO/PG
JET-110 R	JA045100	-35 to +30 °C	35 °C	2-20 K adjustable	-35 to +35 °C	External setting with range restriction, TR	171.70/II
JET-110 RF	JA045200	-35 to +30 °C	35 °C	2-20 K adjustable	-35 to +35 °C	Internal setting with viewing window, TW	172.70/II
JET-120 R	JA046100	0 to 60 °C	70 °C	2-20 K adjustable	-35 to +70 °C	External setting with range restriction, TR	171.70/II
JET-120 RF	JA046200	0 to 60 °C	70 °C	2-20 K adjustable	-35 to +70 °C	Internal setting with viewing window, TW	172.80/II

TR = temperature controller, TW = temperature monitor

ILLUSTRATIONS

JET-1x0 RF



JET-1.

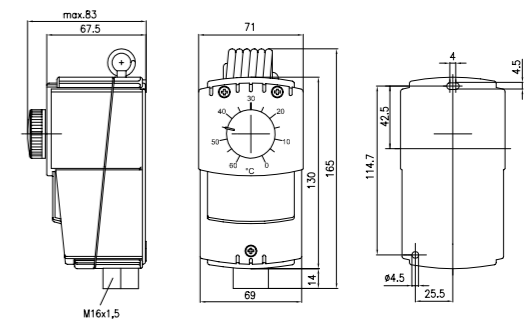

JET-1.

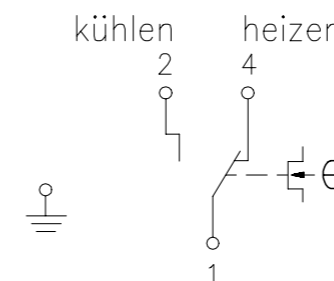

SINGLE-STAGE CAPILLARY THERMOSTATS JET-1

SINGLE-STAGE CAPILLARY THERMOSTATS JET-1

TECHNICAL DATA

Housing colour: grey (lower part similar to RAL 7016, upper part similar to RAL 7035)
Sensor material: Cu (capillaries made from V2A)
Capillary length: 1.8 m (for types with 'G' in the type specification: 4.5 m)
Ambient temperature: -20 to +55 °C
Max. sensor temperature: top scale value +15%
Permissible atmospheric humidity: Max. 95% rel. humidity, non-condensing
Operating voltage: none
Max. switching current: 15 (8) A
Min. switching current: 150 mA
Max. switching voltage: 230 V AC, 50 Hz
Min. switching voltage: 24 VAC, 50 Hz
Switching element: microswitch
Switching contact: toggler, potential-free
Electrical connection: screw-type terminals
Mounting / attachment: wall mounting
Protection rating: IP65
Protection class: I
Safety and EMC: according to DIN EN 60730
Sensor: liquid-filled capillary
General features: scale: degrees Celsius, mechanical range restriction when external setting is used

APPLICATION

Monitoring or control of temperatures of non-aggressive, liquid and gaseous media. Particularly suitable for wall mounting. The SW-200-12 protecting coil is to be used for temperature control of non-aggressive gases in ducts; for temperature control in non-aggressive fluids, use the TH immersion sleeve, and in aggressive fluids, the NTH immersion sleeve.
Immersion sleeves or protection coils are not a part of the scope of delivery (see 'Accessories / Miscellaneous' section).



TYPE	ITEM NO.	CONTROL RANGE	HYSTERESIS ADJUST-ABLE (APPROX.)	SENSOR A X L	FEATURES	EURO/PG
JET-110X	JA040100	-35 to +30 °C	2-20 K	9.6 x 122 mm	external setting / TR*	169.60 / II
JET-110XF	JA040200	-35 to +30 °C	2-20 K	9.6 x 122 mm	internal setting / TW*	170.70 / II
JET-120X	JA041100	0 to 60 °C	2-20 K	9.6 x 122 mm	external setting / TR*	170.20 / II
JET-120XG	JA041101	0 to 60 °C	2-20 K	9.6 x 122 mm	external setting / TR*	193.80 / II
JET-120XF	JA041200	0 to 60 °C	2-20 K	9.6 x 122 mm	internal setting / TW*	170.20 / II
JET-130X	JA042100	40 to 100 °C	2-20 K	9.6 x 122 mm	external setting / TR*	170.40 / II
JET-130XG	JA042101	40 to 100 °C	2-20 K	9.6 x 122 mm	external setting / TR*	197.10 / II
JET-130XF	JA042200	40 to 100 °C	2-20 K	9.6 x 122 mm	internal setting / TW*	171.00 / II
JET-133X	JA042300	40 to 100 °C		9.6 x 122 mm	external setting / TB**	177.50 / II
JET-133XF	JA042400	40 to 100 °C		9.6 x 122 mm	internal setting / TB**	179.00 / II
JET-140X	JA043100	70 to 130 °C	2-20 K	9.6 x 122 mm	external setting / TR*	174.40 / II
JET-140XF	JA043200	70 to 130 °C	2-20 K	9.6 x 122 mm	internal setting / TW*	175.10 / II
JET-143XF	JA043400	70 to 130 °C		9.6 x 122 mm	internal setting / TB**	183.00 / II
JET-150	JA044100	100 to 280 °C	8-50 K	6 x 80 mm	external setting / TR*	170.10 / II
JET-150F	JA044200	100 to 280 °C	8-50 K	6 x 80 mm	internal setting / TW*	170.70 / II
JET-153	JA044300	100 to 280 °C		6 x 80 mm	external setting / TB**	177.00 / II
JET-153F	JA044400	100 to 280 °C		6 x 80 mm	internal setting / TB**	178.40 / II

TR = temperature controller, TW = temperature monitor, TB = temperature limiter

* Control function heating or cooling
 ** Control function heating or cooling, locks when temperature rises, manual reset after temperature fall of at least 8 K

ACCESSORIES

Immersion sleeves for types with 'X' in the type specification: TH/NTH-140 see Page 230
 Immersion sleeves for types without 'X' in the type specification: TH/NTH-100/200/280 see Page 230
 Protection coil for all types: SW-200-12 see Page 229

ILLUSTRATIONS

Temperature monitor (TW)



Temperature limiter (TB)



Temperature controller (TR)

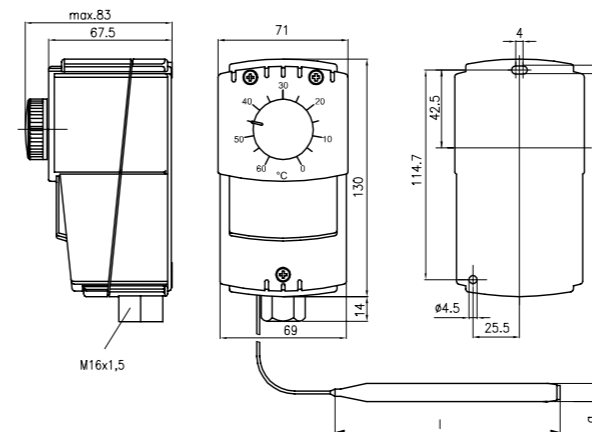

TR/TW

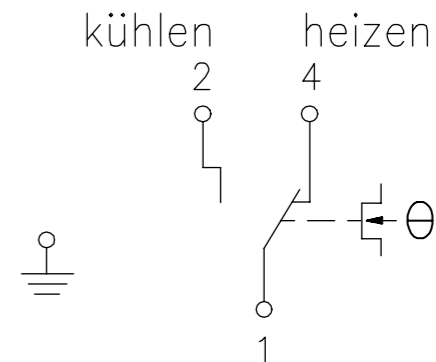

TB

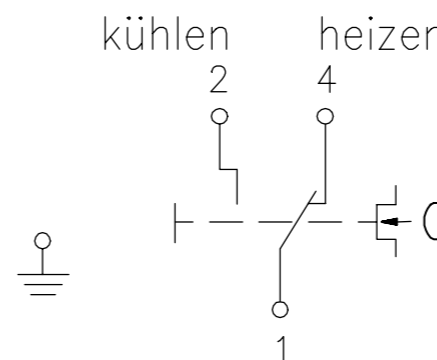

**MULTI-STAGE CAPILLARY THERMOSTAT JMT-206 X**

2 STAGES

**TECHNICAL DATA**

Housing colour:	grey (lower part similar to RAL 7016, upper part similar to RAL 7035)
Sensor material:	Cu
Capillary length:	1.5 m
Ambient temperature:	-15 to +55 °C
Max. sensor temperature:	top scale value +15%
Permissible atmospheric humidity:	Max. 95% rel. humidity, non-condensing
Operating voltage:	none
Max. switching current:	15 (8) A
Min. switching current:	150 mA
Max. switching voltage:	230 V AC, 50 Hz
Min. switching voltage:	24 VAC, 50 Hz
Switching element:	microswitch
Switching contact:	2 x togglers, potential-free
Control function:	2-stage heating, 2-stage cooling, heating or cooling with neutral zone approx. 1–7 K, adjustable
Hysteresis between the stages:	
Electrical connection:	screw-type terminals
Mounting/attachment:	wall mounting
Protection rating:	IP65
Protection class:	I
Safety and EMC:	according to DIN EN 60730
Sensor:	liquid-filled capillary
General features:	scale: degrees Celsius

APPLICATION

Multi-stage control of the temperature of liquid or gaseous media, e.g., for activating two-stage burners or heating registers.

The SW-200-12 protecting coil is to be used for temperature control of non-aggressive gases in ducts; for temperature control in non-aggressive fluids, use the TH immersion sleeve, and in aggressive fluids, the NTH immersion sleeve.

Immersion sleeves or protection coils are not a part of the scope of delivery (see 'Accessories / Miscellaneous' section).

TYPE	ITEM NO.	CONTROL RANGE	HYSTERESIS IN THE STAGE (APPROX.)	SENSOR A X L	FEATURES	EURO/PG
JMT-206 X	E6060340	20 to 80 °C	1 K	9.6 x 122 mm	External setting, TR	247.50 / II

TR = Temperature controller

ACCESSORIES

Immersion sleeves TH-140/NTH-140 (see Page 230), protection coil SW-200-12 (see Page 229)

ILLUSTRATIONS

JMT-2..

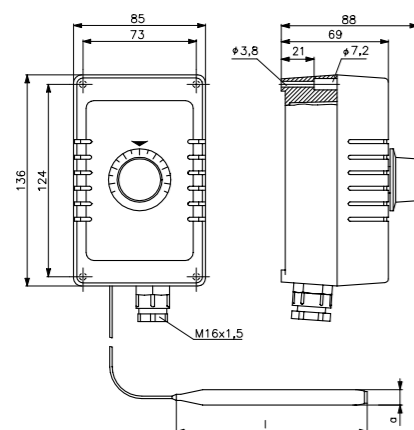

JMT-2..

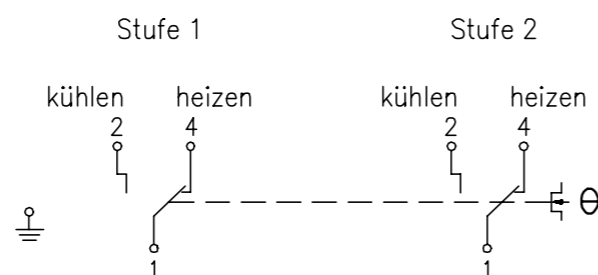
**CONTACT THERMOSTATS ATR 83**

CAPILLARY SYSTEM

**TECHNICAL DATA**

Housing colour:	grey (lower part similar to RAL 7016, upper part similar to RAL 7035)	Application:	Control or monitoring of temperatures at heat registers, pipelines or tanks, for example, temperature-dependent pump control or control of motor valves.
Sensor material:	Cu		
Ambient temperature:	0 to 80 °C		
Permissible atmospheric humidity:	Max. 95% rel. humidity, non-condensing		
Operating voltage:	none		
Max. switching current:	16 (2) A		
Min. switching current:	150 mA		
Max. switching voltage:	230 V AC, 50 Hz		
Min. switching voltage:	24 VAC, 50 Hz		
Switching element:	microswitch		
Switching contact:	toggler, potential-free		
Control function:	heating or cooling		
Hysteresis:	approx. 4 K		
Electrical connection:	screw-type terminals		
Mounting/attachment:	on pipe by means of a cable tie (450 x 8.9 mm, easy to remove, heat-resistant up to 105 °C)		
Protection class:	I		
Safety and EMC:	according to DIN EN 60730		
Sensor:	liquid-filled capillary		
General features:	scale: degrees Celsius		
Scope of delivery:	Controller, cable ties		

TYPE	ITEM NO.	CONTROL RANGE	MAX. SENSOR TEMPERATURE	FEATURES	EURO/PG
ATR 83.000	C1810492	30 to 90 °C	100 °C	external setting, TR, IP20	50.20 / II
ATR 83.100	C1810493	30 to 90 °C	100 °C	internal setting, TW, IP20	46.00 / II
ATR 83.001	C1810494	0 to 60 °C	80 °C	external setting, TR, IP20	50.20 / II
ATR 83.101	C1810495	0 to 60 °C	80 °C	internal setting, TW, IP20	46.00 / II

TR = temperature controller, TW = temperature monitor

ACCESSORIES	ITEM NO.	FEATURES	EURO/PG
ATRS-1	C1809518	Temperature determination set for ATR with external setting (ATR 83.000, ATR 83.001)	3.10 / II
WP-01	G9990180	heat conduction paste 2 ml	7.70 / II

ILLUSTRATIONS

ATR 83. ...

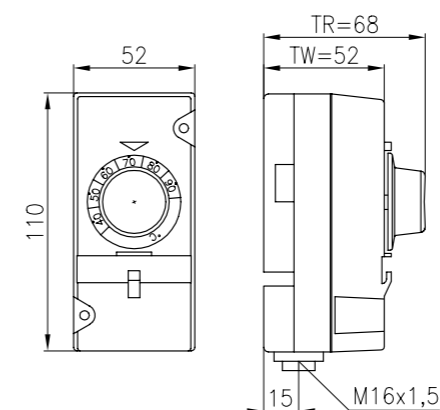

ATR 83. ...

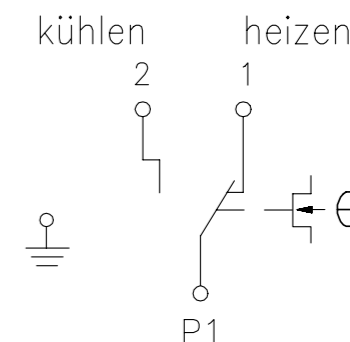



FROST PROTECTION THERMOSTAT RTKSA CAPILLARY SYSTEM – TÜV-TESTED



TECHNICAL DATA

Colour:	Anthracite grey (similar to RAL 7016), front side transparent
Sensor material:	Cu
Max. sensor temperature:	120 °C
Max. head temperature:	80 °C
Permissible atmospheric humidity:	max. 95% rel. humidity, non-condensing
Operating voltage:	none
Max. switching current:	NC contact: 16 (2.5) A at 230 VAC +10% 0.25 A at 230 VDC +10% NO contact STW: 6.3 (2.5) A at 230 VAC +10% 0.25 A at 230 VDC +10% NO contact STB: 2.0 (0.4) A at 230 VAC +10% 0.25 A at 230 VDC +10%
Min. switching current:	Min. 100 mA at 24 V (AC/DC)
Max. switching voltage:	230 VAC 50/60 Hz, 230 VDC
Min. switching voltage:	24 VAC / 50 Hz, 24 VDC
Switching element:	microswitch
Switching contact:	toggler, potential-free
Control range:	-10 to +15 °C
Electrical connection:	Push-in terminals
Mounting/attachment:	Wall mounting; controller housing must be fitted in such a way that the ambient temperature is at least 2 K higher than the setpoint.
Protection class:	I (including switch head and Cu capillary up to 4000 mm)
Safety and EMC:	in accordance with DIN EN 60730 (VDE 0631)
Sensor:	Liquid-filled capillary, active over its entire length (except RTKSA-203.000, RTKSA-204.000, RTKSA-204.020)
General features:	scale: degrees Celsius

APPLICATION

The RTKSA frost protection thermostat was designed especially for ensuring air or water-exposed frost protection for hot-water heating coils and heat exchangers in ventilation, heating or air conditioning systems. The capillaries, except RTKSA-203.000/RTKSA-204.000/RTKSA-204.020, are active along their entire length. The device actuates when the minimum response length of the capillary (at 3 m: 15 cm, at 6 m: 30 cm, at 12 m: 40 cm) reaches the set scale value.

If a sensor rupture occurs, contact 1–2 is permanently opened and contact 1–4 is permanently closed in the STB/STW application. Unlocking is no longer possible with STB.

Air-exposed application:

For the frost protection of heating coils (except RTKSA-203.000/RTKSA-204.000/RTKSA-204.020) the capillaries are braced in front of the heating coil to be protected using mounting brackets. Mounting brackets JZ-05/6 M (metal) or JZ-05/6 K (plastic) should be used for this purpose.

The RTKSA-203.000/RTKSA-204.000/RTKSA-204.020 types can be used in conjunction with the SWK-2-xxx protection coils to measure the temperature of non-aggressive gases in the duct.

Water-exposed application:

The RTKSA-203.000/RTKSA-204.000/RTKSA-204.020 types can be used in conjunction with the TH-140 immersion sleeves for temperature measurement in non-aggressive fluids and in conjunction with the NTH-140 immersion sleeves in aggressive fluids.

Note:

Mounting flanges, immersion sleeves and protecting coils are not part of the delivery scope and must be ordered separately as accessories.

Type testing by TÜV in accordance with DIN EN 14597



FROST PROTECTION THERMOSTAT RTKSA CAPILLARY SYSTEM

TYPE	ITEM NO.	CAPILLARY LENGTH	DEGREE OF PROTECTION	HYSTERESIS	FEATURES	EURO/PG
RTKSA-203.000	KA020300	1.8 m	IP40	+3 K*	STB, internal setting, external reset, sensor dimensions: 9.5 x 98 mm, also for use in water-exposed applications	129.90/II
RTKSA-203.100	KA020301	3 m	IP40	+3 K*	STB, internal setting, external reset	126.00/II
RTKSA-203.120	KA020302	3 m	IP65	+3 K*	STB, internal setting, external reset	185.90/II
RTKSA-203.200	KA020304	6 m	IP40	+3 K*	STB, internal setting, external reset	143.00/II
RTKSA-203.220	KA020303	6 m	IP65	+3 K*	STB, internal setting, external reset	175.20/II
RTKSA-203.300	KA020305	12 m	IP40	+3 K*	STB, internal setting, external reset	200.50/II
RTKSA-204.000	KA020400	1.8 m	IP40	1.5 K	STW, internal setting, Sensor dimensions: 9.5 x 98 mm, also for use in water-exposed applications	107.40/II
RTKSA-204.020	KA020401	1.8 m	IP65	1.5 K	STW, internal setting, Sensor dimensions: 9.5 x 98 mm, also for use in water-exposed applications	180.20/II
RTKSA-204.100	KA020402	3 m	IP40	1.5 K	STW, internal setting	112.10/II
RTKSA-204.200	KA020403	6 m	IP40	1.5 K	STW, internal setting	120.60/II
RTKSA-204.220	KA020404	6 m	IP65	1.5 K	STW, internal setting	185.70/II
RTKSA-204.300	KA020405	12 m	IP40	1.5 K	STW, internal setting	151.10/II

STB = safety temperature limiter, STW = safety temperature monitor

*Manual reset after heating by approx. 3 K

ACCESSORIES	ITEM NO.	FEATURES	EURO/PG
JZ-05/6 K	C1809536	1 set of mounting brackets (6 pieces) for frost protection thermostat RTKSA/JTF, made of plastic (max. 145 °C)	14.50/II
JZ-05/6 M	C1809474	1 set of mounting brackets (6 pieces) for frost protection thermostat RTKSA/JTF, made of metal	15.40/II
JZ-05/1 M	C1809462	Single mounting bracket for frost protection thermostat RTKSA/JTF, made of metal	3.50/II
JZ-29	KA999901	Mounting set for RTKSA THK/NTHK/SWK individual controllers	4.50/II
JZ-33	KA999904	RTKSA seal set, protection rating: IP54	18.50/II

ACCESSORIES	ITEM NO.	LENGTH OF	MATERIAL	DIAMETER IXA**	FEATURES	EURO/PG
TH-140	C1809409	140 mm	nickel-plated brass	10 x 12 mm	Immersion sleeve	30.00/II
NTH-140	C1809435	140 mm	V4A (1.4571)	10 x 12 mm	Immersion sleeve	63.30/II
SWK-2-100	KA989901	100 mm	steel, nickel-plated	10.5 x 17 mm	Protection coil with flange plate	20.80/II
SWK-2-200	KA989903	200 mm	steel, nickel-plated	10.5 x 17 mm	Protection coil with flange plate	26.40/II

** I = minimum inner diameter / A = nominal outer diameter

See page 229 for pictures and dimension diagrams for immersion sleeves/protection coils



FROST PROTECTION THERMOSTAT RTKSA CAPILLARY SYSTEM

TYPE COMPARISON (OLD / NEW TYPE)

OLD ALRE TYPES	CAPILLARY LENGTH	GENERAL FEATURES	NEW ALRE TYPES	CAPILLARY LENGTH	GENERAL FEATURES
JTF-101	6 m	Protection rating: IP54 Hysteresis: approx. 1 K Control range: -8 to +8 °C Tmax sensor: 150 °C	RTKSA-204.200	6 m	Protection rating: IP40 Hysteresis: approx. 1.5 K Control range: -10 to +15 °C Tmax sensor: 120 °C
JTF-103	1.8 m		RTKSA-204.000	1.8 m	
JTF-105	3 m		RTKSA-204.100	3 m	
JTF-112	12 m		RTKSA-204.300	12 m	

ILLUSTRATIONS

RTKSA-203.xxx

RTKSA-204.xxx

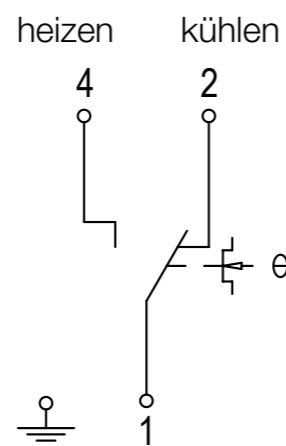
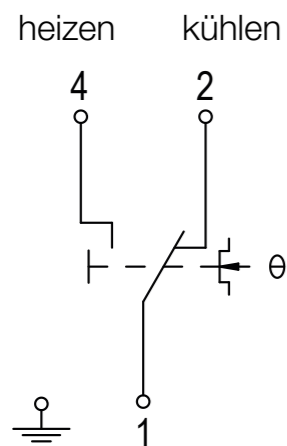

RTKSA-203.xxx

RTKSA-204.xxx

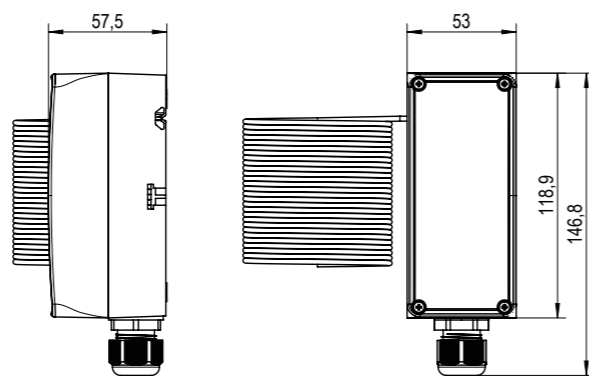
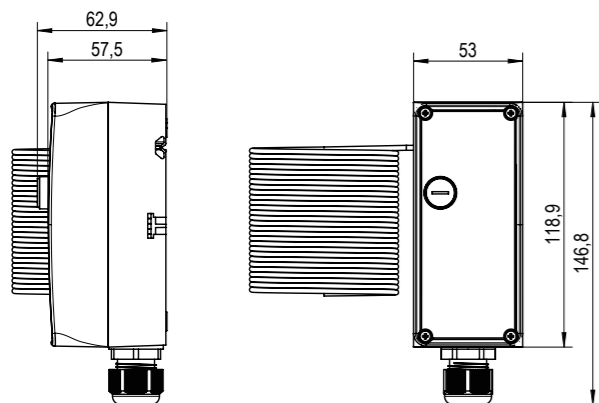

JZ-30



Scan the QR code now and watch the product film 'New thermostats system technology'. More information at a glance.



FROST PROTECTION THERMOSTAT JTF-1 - 25 CAPILLARY SYSTEM - 1 OR 2 STAGES - TÜV-TESTED - SWITCHING

TECHNICAL DATA	APPLICATION
Housing colour: grey	Securing hot water registers against freezing. The frost protection thermostats JTF-21 to JTF-25 have 2 switch outputs that allow for intervention in the system before the critical point is reached. All the devices are intrinsically safe and offer a sealable setpoint configuration. The capillaries, with the exception of JTF-3 / -4, are active over the entire length. The device gets actuated when about 30 cm of the capillary (or approx. 60 cm capillary in the case of 12-m variants) reach the defined value. JTF-1 to -25: For temperature measurement of non-aggressive gases. The mounting brackets JZ-05 / 6 M (metal) or JZ-05 / 6 K (plastic) should be used for bracing the capillaries against the heat register. JTF-3 / -4 (additional application): The SW-200-12 protecting coil is to be used for temperature measurement of non-aggressive gases in the duct; for temperature measurement in non-aggressive fluids, the TH-140 immersion sleeve is to be used, and in aggressive fluids, the NTH-140 immersion sleeve.
Sensor material: Cu	
Ambient temperature	
Permissible atmospheric humidity: Max. 95% rel. humidity, non-condensing	
Max. sensor temperature: 200 °C	
Operating voltage: none	
Max. switching current: 15 (8) A	
Min. switching current: 150 mA	
Max. switching voltage: 230 V AC, 50 Hz	
Min. switching voltage: 24 VAC, 50 Hz	
Switching element: microswitch	
Switching contact: toggler, potential-free	
Control range: -10 to +12 °C	
Electrical connection: screw-type terminals	
Mounting / attachment: wall mounting, controller housing must be fitted in such a way that it is not subjected to any temperature that is less than the scale value that has been set	
Protection class: I	
Safety and EMC: according to DIN EN 60730	
Sensor: gas-filled capillary, active over its entire length (except for JTF-3, JTF-3 W und JTF-4)	
General features: intrinsic safety, scale: degrees Celsius	
Note: Mounting flanges, immersion sleeves and protecting coils are not part of the delivery scope and must be ordered separately as accessories.	
Type testing by TÜV in accordance with DIN EN 14597	

TYPE	ITEM NO.	CAPILLARY LENGTH	FEATURES	EURO / PG
1-STAGE				
JTF-1 *	E6090301	6.0 m	external setting, TR, IP40, hysteresis approx. 1 K	130.10 / II
JTF-1 / 12 *	E6090328	12.0 m	external setting, TR, IP40, hysteresis approx. 1 K	222.50 / II
JTF-1 W *	E6090014	6.0 m	internal setting, TW, IP65, hysteresis approx. 1 K	199.10 / II
JTF-3 *	E6090309	1.8 m	external setting, TR, IP 40, hysteresis approx. 1 K, sensor dimensions: 9.5 x 76 mm, also for use in applications exposed to water	125.00 / II
JTF-3 W *	E6090065	1.8 m	internal setting, TW, IP 65, hysteresis approx. 1 K, sensor dimensions: 9.5 x 76 mm, also for use in applications exposed to water	193.70 / II
JTF-5 *	E6090311	3.0 m	external setting, TR, IP40, hysteresis approx. 1 K	126.40 / II

FROST PROTECTION THERMOSTAT JTF-1 – 25

CAPILLARY SYSTEM – 1 OR 2 STAGES – TÜV-TESTED – SWITCHING

TYPE	ITEM NO.	CAPILLARY LENGTH	FEATURES	EURO/PG
2-STAGE: 1. STAGE EMITS A SIGNAL 5 K BEFORE THE SWITCH-OFF POINT				
JTF-21 ***	E6090320	6.0 m	external setting, TR, IP40, hysteresis in the stage approx. 1 K, hysteresis between the stages approx. 5 K	178.80/II
JTF-21/12 ***	E6090330	12.0 m	external setting, TR, IP40, hysteresis in the stage approx. 1 K, hysteresis between the stages approx. 5 K	310.00/II
JTF-21 W ***	E6090283	6.0 m	internal setting, TW, IP 65, hysteresis in the stage approx. 1K, hysteresis between the stages approx. 5 K	247.00/II
JTF-25 ***	E6090324	3.0 m	external setting, TR, IP40, hysteresis in the stage approx. 1 K, hysteresis between the stages approx. 5 K	174.90/II

TR = temperature controller, TW = temperature monitor, TB = temperature limiter

- * Control function heating or cooling
- ** Control function heating or cooling, locked when the temperature is dropping
- *** Control function heating or cooling, 1st stage emits a signal 5 K before the switch-off signal
- **** Control function heating or cooling, 1st stage emits a signal 5 K before the switch-off signal, locks at dropping temperature (manual reset after temperature rise of approx. 4 K)

ACCESSORIES	ITEM NO.	FEATURES	EURO/PG
JZ-04	E6160133	Capillary tube leadthrough for air ducts with 30-cm protective hose	15.30/II
JZ-05 / 6 K	C1809536	1 set of mounting brackets (6 pieces) for frost protection thermostat JTF, made of plastic (max. 145 °C)	14.50/II
JZ-05 / 6 M	C1809474	1 set of mounting brackets (6 pieces) for frost protection thermostat JTF, made of metal	15.40/II
JZ-05 / 1 M	C1809462	Single mounting bracket for frost protection thermostat JTF, made of metal	3.50/II
JZ-07	E6160145	mounting bracket for frost protection thermostat JTF	6.90/II
TH-140	C1809409	immersion sleeve for JTF-3, JTF-4; material nickel-plated brass	30.00/II
NTH-140	C1809435	immersion sleeve for JTF-3, JTF-4; material V4A (1.4571)	63.30/II
SW-200-12	C1809220	protecting coil for JTF-3, JTF-4 to attach capillary in the air duct; made of nickel-plated steel	34.40/II

ILLUSTRATIONS

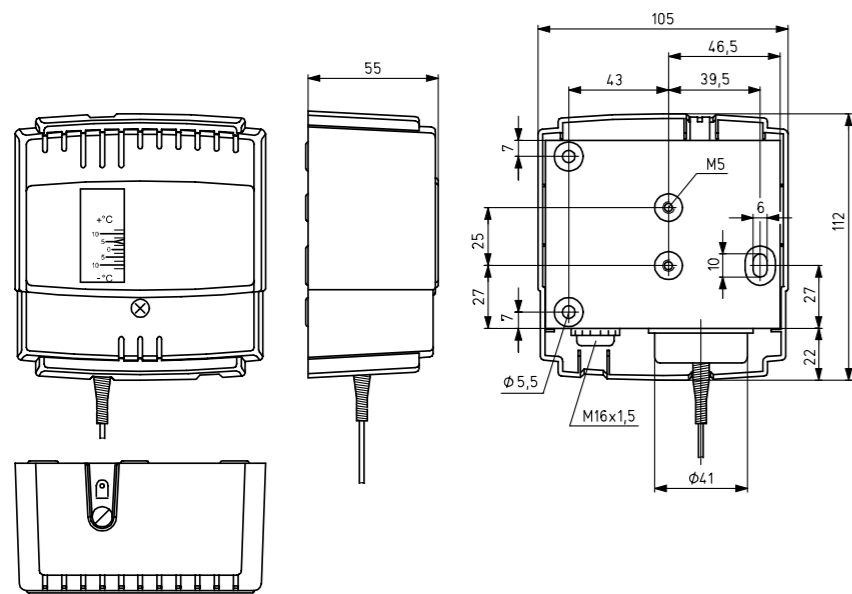

FROST PROTECTION THERMOSTAT JTF-1 – 25

CAPILLARY SYSTEM – 1 OR 2 STAGES – TÜV-TESTED – SWITCHING

ILLUSTRATIONS

JTF-1 / -3 / -5

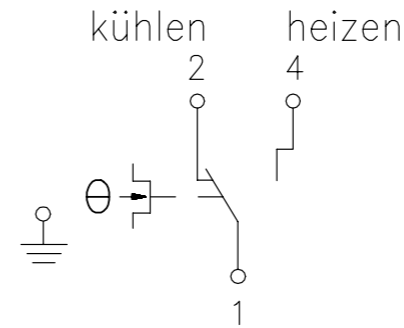

JTF-2 / -4

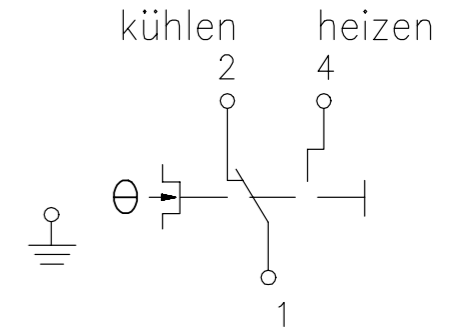

JTF-21 / -25

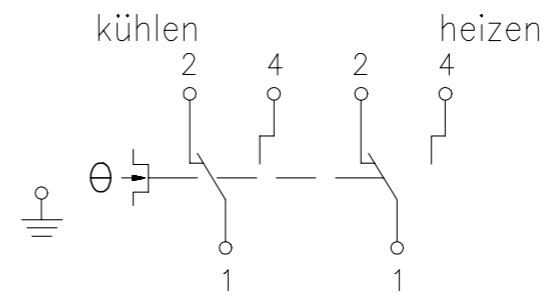

JTF-22

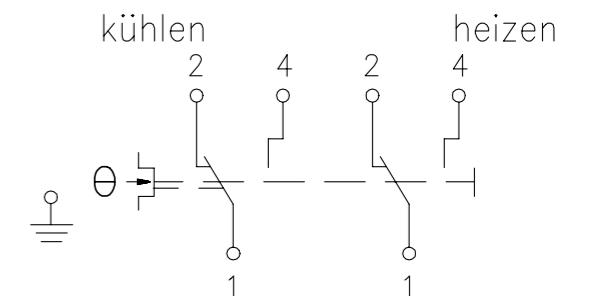

JTF-..W

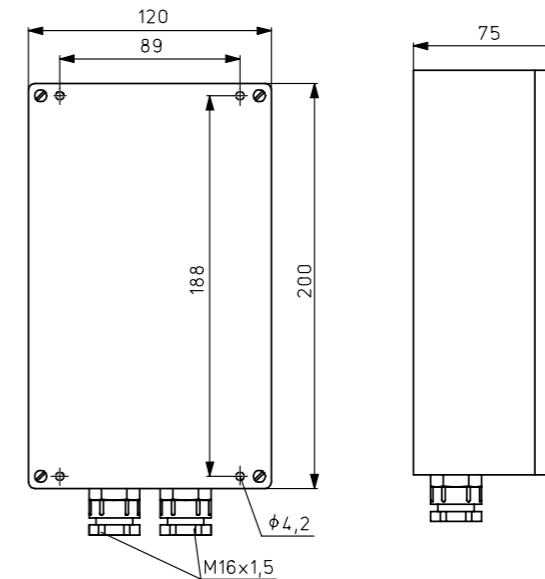

AIR HEATER THERMOSTAT JTL-2...-11 / JTL-8 NR...-17 NR

CAPILLARY SYSTEM – 2 FUNCTIONS OR 3 FUNCTIONS – TÜV-TESTED

AIR HEATER THERMOSTAT JTL-2...-11 / JTL-8 NR...-17 NR

CAPILLARY SYSTEM – 2 FUNCTIONS OR 3 FUNCTIONS – TÜV-TESTED



TECHNICAL DATA

Housing colour:	grey
Sensor material:	Cu
Ambient temperature:	-15 to +80 °C
Permissible atmospheric humidity:	Max. 95% rel. humidity, non-condensing
Max. sensor temperature:	200 °C
Operating voltage:	none
Max. switching current:	15 (8) A
Min. switching current:	150 mA
Max. switching voltage:	230 V AC, 50 Hz
Min. switching voltage:	24 VAC, 50 Hz
Switching element:	microswitch, toggler, potential-free
Control function:	heating or cooling
Control range (fan):	20 to 70 °C
Hysteresis (fan):	adjustable approx. 8–30 K
Electrical connection:	screw-type terminals
Mounting / attachment:	mounting on air duct
Protection rating:	IP20
Protection class:	I
Safety and EMC:	according to DIN EN 60730
Sensor:	liquid-filled capillary, active over its entire length
General features:	intrinsic safety, protection against cold, internal setting, scale: degrees Celsius
Operating elements:	fan switch

APPLICATION

Minimum or maximum thermostat for inflow air monitoring and fan regulation in ventilation and air conditioning systems. Overheating protection thermostat for electrical heat registers and directly fired air heaters with oil and gas operation.

The "MAN - AUTO" switch can be used to switch the fan on and off in summer for ventilation.

Type ... NR: Temperature-controlled fan regulation, burner monitoring and safety temperature limiter, 3 functions.

Attention: Assemble the device in a vibration-free manner in order to avoid malfunctions and/or sensor rupture.

Type-tested by TÜV in accordance with DIN EN 14597
For hot air heaters in accordance with DIN 4794



TYPE	ITEM NO.	CONTROL RANGE BURNER	HYSTERESIS OF BURNER (APPROX.)	CAPILLARY LENGTH	FEATURES*	EURO/PG
JTL-2	E6110013	70 to 100 °C	8 K	350 mm	TW	254.20/II
JTL-8	E6110049	70 to 100 °C	external reset	350 mm	STB, locked when the temperature is rising, overheating protection	258.20/II
JTL-11	E6110064	70 to 100 °C	8 K	1250 mm	TW	273.60/II
JTL-8 NR	E6120038	70 to 95 °C	8 K	350 mm	locked when the temperature is rising, TW / STB, tolerances: STB +0/-10 K, overheating protection, external reset STB, shut-off temperature STB fixed: 100 °C	384.90/II
JTL-17 NR	E6120077	70 to 95 °C	8 K	1,250 mm	locked when the temperature is rising, TW / STB, tolerances: STB +0/-10 K, overheating protection, external reset STB, shut-off temperature STB fixed: 100 °C	404.50/II

* TW = temperature monitor, STB = safety temperature limiter

JTL-4 is replaced by JTL-8.
JTL-4 NR is replaced by JTL-8 NR.

Intrinsic safety / protection against cold: The devices are intrinsically safe, i.e., upon loss of the sensor medium owing to sensor rupture, for example, the burner is switched off. Since minus temperatures generate the same effect through volume reduction of the sensor medium, the devices are adjusted by means of the 'cold screw' such that they switch off the burner only at temperatures below -15 °C. They can only be switched on again manually at temperatures above approx. -5 °C by means of the manual reset button.

Overheating protection: This device provides protection from uncontrolled overheating caused, for example, by heat building up or by creeping capillary filling losses when there is invisible damage to the sensor or the capillary tube, etc. Upon reaching a temperature of 220 °C, the safety slot in the sensor melts and, in reaction to losing the filling medium, the device switches off the burner towards the safe side. The burner cannot be switched on again. The device is then unusable and serves as evidence of the presence of an over-temperature of at least 220 °C.

Locking: For types JTL-8, JTL-8 NR and JTL-17 NR, a restart after cooling down is only possible by manual reset.

ILLUSTRATIONS

JTL-17 NR



JTL-2



JTL-.. NR

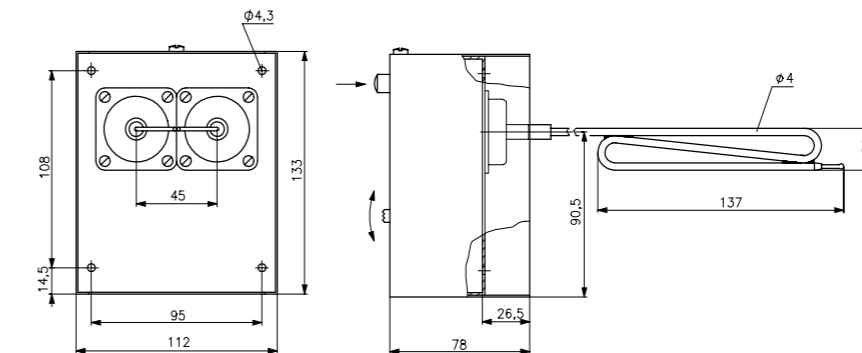

JTL-..

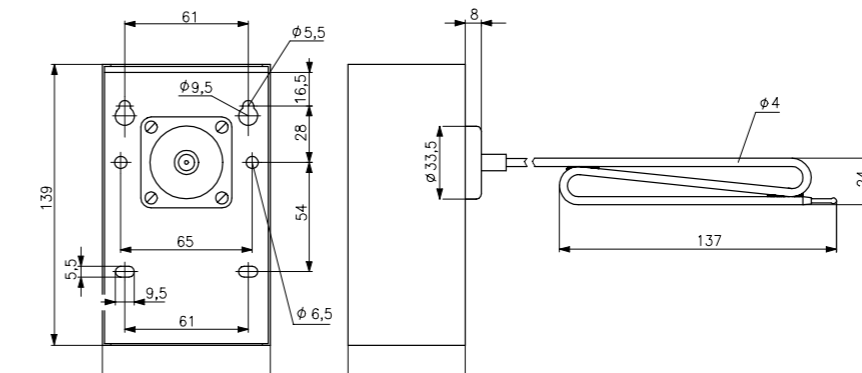

ILLUSTRATIONS

JTL-.. NR

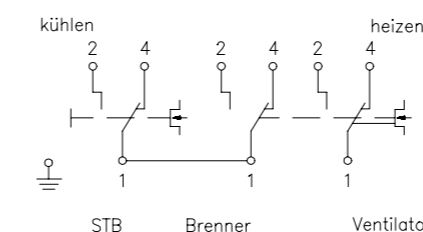

JTL.. (TW)

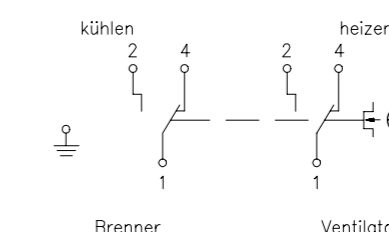

JTL-.. (STB)

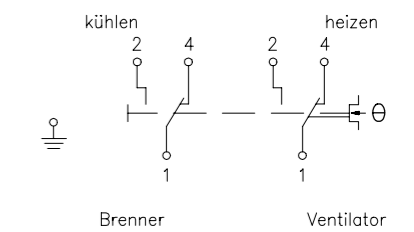



DUCT THERMOSTAT JTU-1 ... -50

CAPILLARY SYSTEM – TÜV-TESTED

TECHNICAL DATA

Housing colour:	grey
Sensor material:	Cu
Ambient temperature:	-15 to +80 °C
Permissible atmospheric humidity:	Max. 95% rel. humidity, non-condensing
Max. sensor temperature:	200 °C
Operating voltage:	none
Max. switching current:	15 (8) A
Min. switching current:	150 mA
Max. switching voltage:	230 V AC, 50 Hz
Min. switching voltage:	24 VAC, 50 Hz
Switching element:	microswitch
Switching contact:	toggler, potential-free
Electrical connection:	screw-type terminals
Mounting / attachment:	mounting on air duct
Protection rating:	IP40
Protection class:	I
Safety and EMC:	according to DIN EN 60730
Sensor:	liquid-filled capillary, active over its entire length
General features:	internal setting, scale: degrees Celsius

APPLICATION

Minimum or maximum thermostat for inflow air monitoring and fan regulation in ventilation and air conditioning systems.

Overheating protection thermostat for electrical heat registers and directly fired air heaters with oil and gas operation.

Attention: Assemble the device in a vibration-free manner in order to avoid malfunctions and/or sensor rupture.

JTU-20, -3:
Type testing by TÜV in accordance with DIN EN 14597,
for hot air heaters in accordance with DIN 4794



TYPE	ITEM NO.	CONTROL RANGE	HYSTERESIS (APPROX.)	CAPILLARY LENGTH	FEATURES	EURO/PG
JTU-50	E6100000	-25 to +65 °C	1.5 K	350 mm	Control function: heating or cooling, TW	184.10/II
JTU-1	E6100012	c	8-30 K adjustable	350 mm	Control function: heating or cooling, TW, intrinsic safety, protection against cold	215.20/II
JTU-3	E6100036	20 to 100 °C	external reset	350 mm	Control function: heating or cooling, locked when the temperature is rising, STB, intrinsic safety, protection against cold, overheating protection	188.20/II
JTU-20	E6100075	20 to 100 °C	external reset	1250 mm	Control function: heating or cooling, locked when the temperature is rising, STB, intrinsic safety, protection against cold	205.30/II
JTU-5	E6100048	60 to 140 °C	8-30 K adjustable	350 mm	Control function: heating or cooling, TW	214.20/II
JTU-6	E6100051	60 to 140 °C	external reset	350 mm	Control function: heating or cooling, locked when the temperature is rising, TB	185.90/II

TW = temperature monitor, STB = safety temperature limiter, TB = temperature limiter

JTU-2 is replaced by JTU-3.

Intrinsic safety / protection against cold: The devices are intrinsically safe, i.e., upon loss of the sensor medium owing to sensor rupture, for example, the burner is switched off. Since minus temperatures generate the same effect through volume reduction of the sensor medium, the devices are adjusted by means of the 'cold screw' such that they switch off the burner only at temperatures below -15 °C. They can only be switched on again manually at temperatures above approx. -5 °C by means of the manual reset button.

Overheating protection: This device provides protection from uncontrolled overheating, which is caused, for example, by a heat build-up or by creeping capillary filling losses when there is invisible damage to the sensor or the capillary tube etc. Upon reaching a temperature of 220 °C, the safety slot in the sensor melts and, in reaction to losing the filling medium, the device switches off the burner towards the safe side. The burner cannot be switched on again. The device is then unusable and serves as evidence of the presence of an over-temperature of at least 220 °C.

Locking: For types JTU-3, JTU-6 and JTU-20, a restart after cooling down is only possible by manual reset.



DUCT THERMOSTAT JTU-1 ... -50

CAPILLARY SYSTEM – TÜV-TESTED

ILLUSTRATIONS

JTU-20



JTU-3/-6



JTU

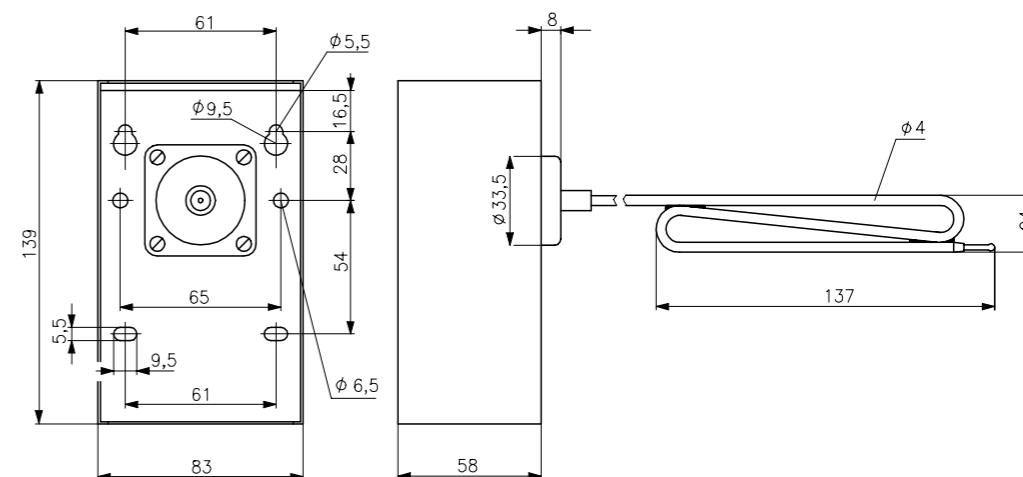

JTU-1, -5, -50

JTU-3/-6/-20

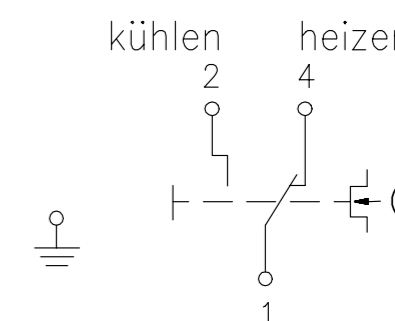
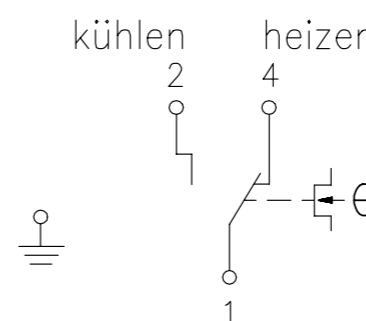

CONTROL CABINET THERMOSTATS, ELECTRONIC FOR PELTIER MODULES - HEATING / COOLING



TECHNICAL DATA

Housing colour:	light grey RAL7035
Housing material:	Polyamide PA 6.6 (UL94 V-0)
Supply voltage:	24VDC, ±15%
Switching capacity:	max. 16 A
Output:	Relays with voltage-free changeover contact
Power consumption:	0.75 W
Control range:	0 to 60 °C
Switching difference (hysteresis):	approx. 2–3 K
Sensor:	internal NTC
Protection class:	III
Protection rating:	IP30
Operating temperature:	-10 to +70 °C
Storage temperature:	-20 to 70 °C
Permissible humidity:	max. 95% rel. humidity, non-condensing
Electrical connections:	screw-type terminals 0.5 to 2.5 mm ²
Mounting type:	DIN standard rail (35 mm)

APPLICATION

This temperature controller was specially developed for controlling Peltier modules, for heating or cooling control cabinets, ticket machines and cash points and for reporting information on heating and cooling and requirements.

Function:
The CTRRS uses an internal sensor to measure the air temperature in control cabinets and activates heating or cooling when the temperature exceeds or falls below the established setpoint.

Mounting: The controller is installed on a 35-mm DIN standard rail.
Mounting set JZ-13 is used when mounting on a sheet metal wall or profile frame.

TYPE	ITEM NO.	CONTROL RANGE	FEATURES	EURO/PG
CTRRS-161.000/06	DN600007	0 to 60 °C		57.00/II

ACCESSORIES	ITEM NO.	FEATURES	EURO/PG
JZ-13	ZA990001	Standard rail with drilled holes for fastening control cabinet controllers (length 40 mm)	6.00/II

JZ-13 mounting set consisting of a 38 mm long standard rail, screw and tooth lock washer
Attention: The controller can only be set to one operating mode, either heating or cooling. The changeover contact, when using Peltier elements, is not intended to activate heating or cooling by reversing the current. The CTRRS features an internal sensor. In order to gauge the internal temperature of the control cabinet, it must not be exposed to direct sources of cold or heat, unless doing so concerns the assembly to be protected.

ILLUSTRATIONS

Connection in cooling mode

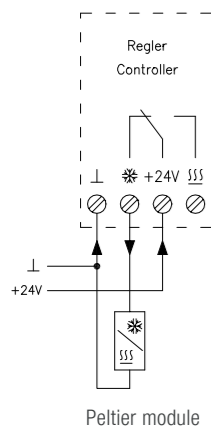

Connection in heating mode

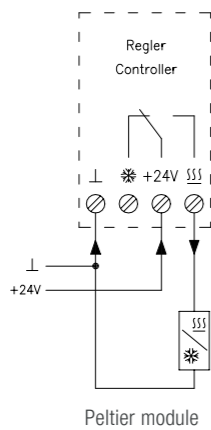

CTRRS-161.000

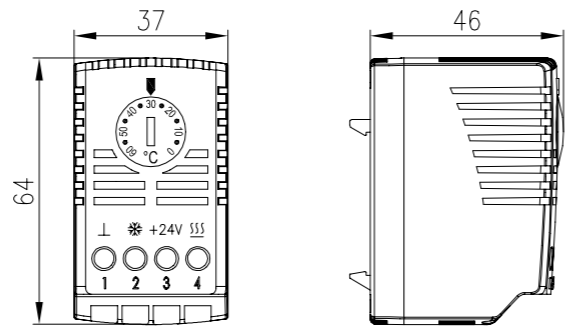

- Terminal 1: Supply voltage (mass)
- Terminal 2: Output 'cooling'
- Terminal 3: Supply and switching voltage (+24 V4)
- Terminal 4: Output 'heating'

CONTROL CABINET THERMOSTATS ELECTRONIC, FOR PELTIER MODULE – HEATING / COOLING



TECHNICAL DATA

Housing colour:	light grey RAL7035
Housing material:	ABS plastic
Supply voltage:	24VDC, ±15%
Switching capacity:	max. 16 A
Output (Peltier element):	16 A relay output, Caution! As of 10 A or higher than 30 °C, wiring must not be done using 1.5 mm ² , but rather must be wired using the next highest cross-section of 2.5 mm ²
Output (fan):	2(1)A relay output
Power consumption:	approx. 1 W
Control range (heating):	0 to 20 °C
Control range (cooling):	30 to 50 °C
Switching difference (hysteresis):	approx. 1 K
Sensor:	internal or external NTC 2 K
Sensor tolerance:	approx. 1 K
Protection class:	III
Protection rating:	IP20
Admissible ambient temperature:	-10 to +55 °C, Caution! As of 30 °C or higher than 10 A, consider a 2.5 mm ² connection cross-section
Storage temperature:	-20 to 70 °C
Permissible humidity:	max. 95% rel. humidity, non-condensing
Electrical connections:	screw-type terminals 0.5 to 2.5 mm ²
Mounting type:	DIN standard rail (35 mm)

APPLICATION

This controller was specially designed for controlling Peltier modules that have fans for the purpose of air conditioning control cabinets.

The KTRRN features two control ranges for heating and cooling. The switching point for heating is selected in the lower setting range, and the switching point for cooling is selected in the upper setting range. The setting ranges are divided into ranges of 10 K. Therefore a neutral zone of at least 10 K is always given, and incorrect switching point settings / switching point overlaps created by the installer are avoided.

The controller is installed on a DIN standard rail. Mounting set JZ-13 is used when mounting on a sheet metal wall or profile frame.

Mounting: The controller is installed on a 35-mm DIN standard rail.
Mounting set JZ-13 is used when mounting on a sheet metal wall or profile frame.

TYPE	ITEM NO.	CONTROL RANGE	FEATURES	EURO/PG
KTRRN-267.014	DA460002	0 to 20 °C (heating) / 30 to 50 °C (cooling)		115.40/II

ACCESSORIES	ITEM NO.	FEATURES	EURO/PG
JZ-13	ZA990001	Standard rail with drilled holes for fastening control cabinet controllers (length 40 mm)	6.00/II
HF-8/4-K2	G8000370	External sensor NTC 2K as sleeve sensor HF-8/4-K2	26.50/II

ILLUSTRATIONS

KTRRN-267.014

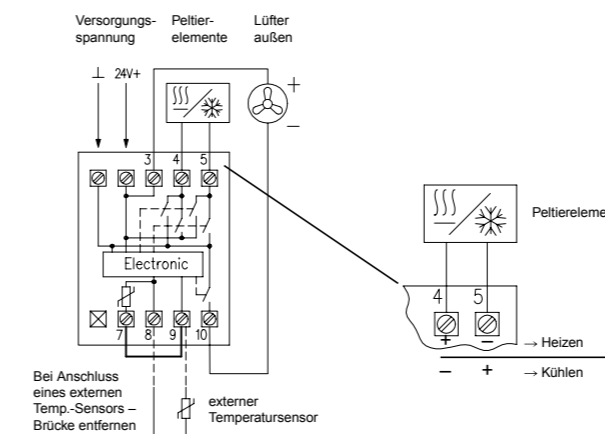

KTRRN-267.014

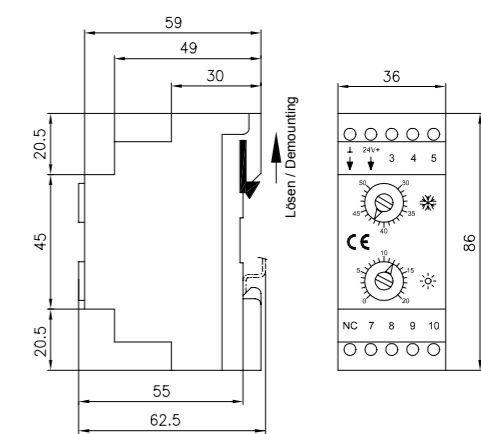



CONTROL CABINET THERMOSTATS

MECHANICAL, BIMETAL







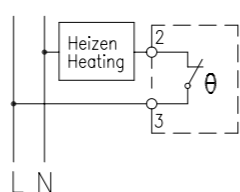

TECHNICAL DATA

Housing colour:	grey, similar to RAL 7035
Ambient temperature:	0 to 60 °C
Permissible atmospheric humidity:	Max. 95% rel. humidity, non-condensing
Max. switching voltage:	230 VAC / 50 Hz, 48 VDC
Min. switching voltage:	24 VAC / 50 Hz, 24 VDC
Min. switching current:	The resistance of the contact transition results in a voltage drop across the contact. This can have a strong influence on very small switching signals.
Switching element:	bimetallic contact
Hysteresis:	Approx. 4 to 7 K (RTBSS-112.211 / 12 approx. 1 K at operating voltage of 230 VAC) at a temperature change of max. 4 K/h
Electrical connection:	screw-type terminals 0.5 mm ² to 2.5 mm ²
Mounting / attachment:	on supporting rails (35 mm) according to EN 60715
Protection rating:	IP30
Protection class:	0, determined by the assembly location according to DIN EN 60730
Safety and EMC:	according to DIN EN 60730
Sensor:	bimetal
Function type:	TR (temperature controller)
General features:	external setting, scale: degrees Celsius, snap-lock control button
Test mark / approbation:	UL, VDE

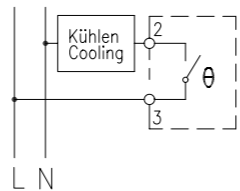
APPLICATION

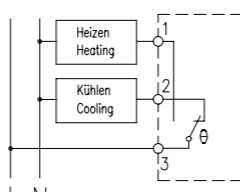
Application scenarios include temperature monitoring in control cabinets, machines and housings.

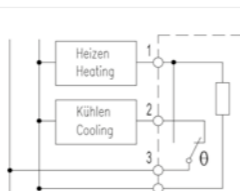
TYPE/IMAGE	ITEM NO.	FEATURES	CIRCUIT DIAGRAM	EURO/PG
	RTBSS-110.250/04	ZN111524 Max. switching current: 10 (2) A / VAC, max. 30 W / VDC Switching contact: NC contact Control function: heating Control range: 0 to 60 °C scale red		20.40 / II
	RTBSS-111.250/05	ZN112525 Max. switching current: 10 (2) A / VAC, max. 30 W / VDC Switching contact: NO contact Control function: Cooling Control range: 0 to 60 °C scale blue		20.40 / II
	RTBSS-112.250/07	ZN113527 Max. switching current: NC contact 10 (2) A / VAC, max. 30 W / VDC NO contact 5 (2) A / VAC, max. 30 W / VDC Switching contact: changeover Control function: heating or cooling Control range: 0 to 60 °C scale grey		26.50 / II
	RTBSS-112.211/12	ZN113152 Max. switching current: NC contact 10 (2) A / VAC, max. 30 W / VDC NO contact 5 (2) A / VAC, max. 30 W / VDC Switching contact: changeover Control function: heating or cooling Control range: 0 to 60 °C Scale grey, thermal feedback		29.20 / II

ACCESSORIES	ITEM NO.	FEATURES	EURO/PG
JZ-13	ZA990001	Standard rail with drilled holes for fastening control cabinet controllers (length 40 mm)	6.00 / II

See page 191 for dimension diagram (RFHSS / RTBSS)



CONTROL CABINET HYGROSTATS

WITH CHANGEOVER CONTACT



TECHNICAL DATA

Housing colour:	grey, similar to RAL 7035
Operating voltage:	none
Max. switching current:	De-humidifying: 5 (0.2) A, Humidifying: 2 (0.2) A
Min. switching current:	100 mA at 24 VAC
Max. switching voltage:	230 V AC, 50 Hz
Min. switching voltage:	24 VAC, 50 Hz
Switching element:	microswitch
Switching contact:	changeover
Control function:	humidifying or de-humidifying
Mounting / attachment:	on supporting rails (35 mm) according to EN 60715
Protection rating:	IP30
Protection class:	0, determined by the assembly location according to DIN EN 60730
Safety and EMC:	according to DIN EN 60730
Sensor:	plastic fibres
Function type:	controller
General features:	external setting
Test mark / approbation:	RFHSS-114.110 / 01 UL at 230 VAC

APPLICATION

Hygrostat for monitoring and controlling humidity in control cabinets and machines

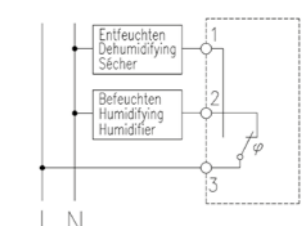
TYPE/IMAGE	ITEM NO.	FEATURES	CIRCUIT DIAGRAM	EURO/PG
	RFHSS-114.110/01	ZN275001 Ambient temperature: 0 to 60 °C Admissible humidity: max. 95% rel. humidity, non-condensing Control range: 40–90% rel. humidity Hysteresis: approx. 5% rel. humidity Electrical connection: screw-type terminals 0.5 mm ² –2.5 mm ² Test mark / approbation: UL for 230 VAC snap-in turning knob		74.80 / II

ACCESSORIES	ITEM NO.	FEATURES	EURO/PG
JZ-13	ZA990001	Standard rail with drilled holes for fastening control cabinet controllers (length 40 mm)	6.00 / II

ILLUSTRATIONS

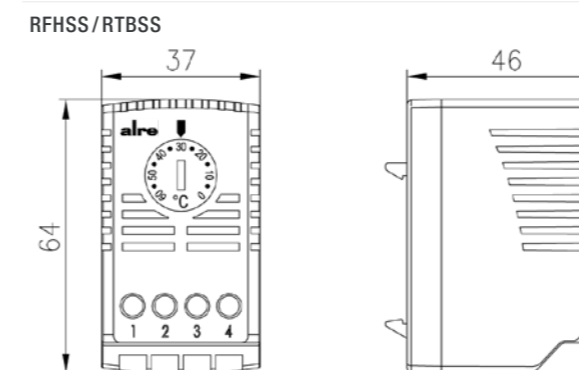

CONTROLLER FOR DISTRIBUTOR ASSEMBLY (HAT RAIL) ITR 79 REMOTE SENSOR, ELECTRONIC



TECHNICAL DATA

Housing colour:	grey, similar to RAL 7035
Ambient temperature:	-10 to +40 °C
Permissible atmospheric humidity:	Max. 95% rel. humidity, non-condensing
Operating voltage:	230 V AC, 50 Hz
Max. switching current:	NO contact: 10 (2) A, NC contact: 5 (1.5) A
Min. switching current:	The resistance of the contact transition results in a voltage drop across the contact. This can have a strong influence on very small switching signals.
Max. switching voltage:	230 V AC, 50 Hz
Min. switching voltage:	5 VAC, 50 Hz
Switching element:	relay
Switching contact:	toggler, potential-free
Electrical connection:	screw-type terminals up to 2.5 mm ² on supporting rails (35 mm) according to EN 60715
Mounting / attachment:	
Protection rating:	IP20
Protection class:	II
Safety and EMC:	according to DIN EN 60730
Function type:	TR (temperature controller)
General features:	external setting

APPLICATION

Control and monitoring of the temperature in large halls, greenhouses and floor heating systems. The devices have sensor rupture and sensor short-circuit protection.

Sensors are not a part of the delivery scope (except for ITR 79.804) For available sensors, see the 'Sensor technology' section.

Use sensors according to the specified sensor number (for example, for sensor number 4: All sensors with this number can be used, e.g., KF-4). Avoid parallel routing of sensor wires together with mains voltage-bearing wires or use shielded wires.

TYPE	ITEM NO.	CONTROL RANGE	FEATURES	EURO/PG
ITR 79.402	D4780167	-35 to +15 °C	Control function: heating, hysteresis adjustable: approx. 0.5–5 K, sensor: NTC 1 K (sensor 1), scale: degrees Celsius, display 'heating' red	112.60/II
ITR 79.404	D4780155	0 to 60 °C	Control function: heating, hysteresis adjustable: approx. 0.5–5 K, sensor: NTC 10 K (sensor 4), scale: degrees Celsius, display 'heating' red	112.60/II
ITR 79.405	D4780181	35 to 95 °C	Control function: heating, hysteresis adjustable: approx. 0.5–5 K, sensor: NTC 50 K (sensor 5), scale: degrees Celsius, display 'heating' red	112.60/II
ITR 79.408	D4780179	-10 to +40 °C	Control function: heating, hysteresis adjustable: approx. 0.5–5 K, sensor: NTC 8 K (sensor 3), scale: degrees Celsius, display 'heating' red	117.60/II
ITR 79.503	D4780524	0 to 11 °C	Control function: heating, frost protection locked when the temperature is dropping, hysteresis approx. 1.5 K, sensor: NTC 2 K 25 (sensor 0), scale: degrees Celsius, display 'heating' red	127.70/II
ITR 79.504	D4780371	0 to 60 °C	Control function: cooling, hysteresis adjustable: approx. 0.5–5 K, sensor: NTC 10 K (sensor 4), scale: degrees Celsius, display 'cooling' green	117.60/II
ITR 79.508	D4780369	-10 to +40 °C	Control function: cooling, hysteresis adjustable: approx. 0.5–5 K, sensor: NTC 8 K (sensor 3), scale: degrees Celsius, display 'cooling' green	117.60/II

TWO SETPOINT ADJUSTERS (E.G., DAY/NIGHT TEMPERATURE VIA EXTERNAL CLOCK) EURO/PG

TYPE	ITEM NO.	CONTROL RANGE	FEATURES	EURO/PG
ITR 79.600	D4780508	2 x 5 to 30 °C	Control function: heating, hysteresis: approx. 0.5 K, sensor: NTC 47 K (sensor 2), ECO contact: toggling between setpoint value 1 and setpoint value 2, scale: degrees Celsius	131.80/II

COMPLETE DEVICE INCLUDING REMOTE SENSOR HF-8/4-K2 (4-M CABLE) EURO/PG

TYPE	ITEM NO.	CONTROL RANGE	FEATURES	EURO/PG
ITR 79.804	D4780545	0 to 60 °C	Control function: heating, hysteresis adjustable: approx. 0.5–5 K, sensor: NTC 2 K (sensor 8), multi-digit scale 0–6, display 'heating' red	150.70/II

ACCESSORIES EURO/PG

ACCESSORIES	ITEM NO.	FEATURES	EURO/PG
JZ-13	ZA990001	Standard rail with drilled holes for fastening control cabinet controllers (length 40 mm)	6.00/II

CONTROLLER FOR DISTRIBUTOR ASSEMBLY (HAT RAIL) ITR 79 REMOTE SENSOR, ELECTRONIC

ILLUSTRATIONS

ITR 79.4... / .5... / .8...

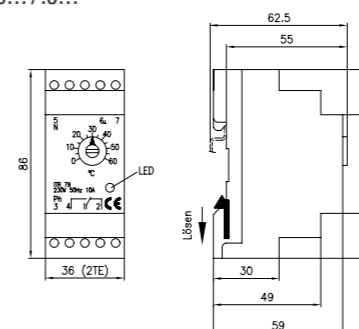

ITR 79.4... / .5... / .8...

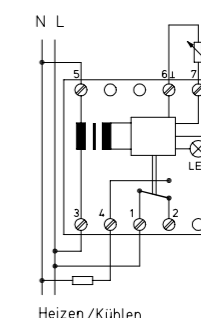

ITR 79.804



ITR 79.6

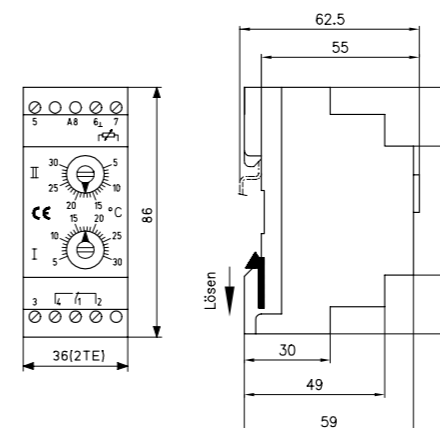

ITR 79.6

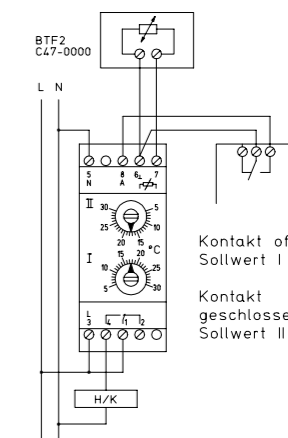

ITR 79.503

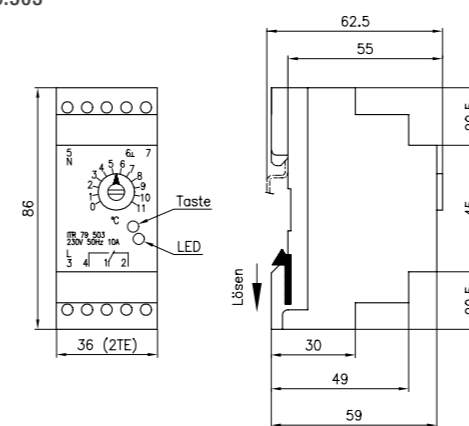

ITR 79.503

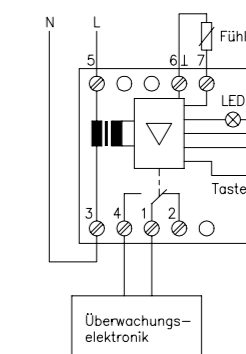



UNIVERSAL CONTROLLER ETR 77

REMOTE SENSOR, ELECTRONIC

**TECHNICAL DATA**

Housing colour:	grey (lower part similar to RAL 7016, upper part similar to RAL 7035)
Ambient temperature:	-20 to +50 °C
Permissible atmospheric humidity:	Max. 95% rel. humidity, non-condensing
Operating voltage:	230 V AC, 50 Hz
Max. switching current:	NO contact: 10 (3) A (heating), NC contact: 5 (1.5) A (cooling)
Max. switching voltage:	230 V AC, 50 Hz
Switching element:	relay
Switching contact:	toggler, potential-free
Control function:	heating or cooling
Electrical connection:	screw-type terminals
Mounting / attachment:	wall mounting
Protection class:	II
Sensor:	KTY 81-121 (sensor 51)

APPLICATION

Thanks to various sensor models suitable for universal use in heating, ventilation, air-conditioning and refrigeration technology as well as in mechanical and plant engineering.

Sensors are not a part of the delivery scope.

For available sensors, see below or the 'Sensor technology' section.

Note: The sensor line must be routed in a protective pipe. Parallel routing together with lines that carry alternating currents is not permitted.

Safety and EMC: according to DIN EN 60730

TYPE	ITEM NO.	CONTROL RANGE	FEATURES	HYSTERESIS ADJUSTABLE	EURO/PG
ETR 77.008-5	D4770014	-50 to +50 °C	IP65, TW, internal setting, scale: degrees Celsius	0.5-5 K	138.10/II
ETR 77.009-5	D4770026	0 to 100 °C	IP65, TW, internal setting, scale: degrees Celsius	0.5-5 K	137.20/II

TW = Temperature monitor

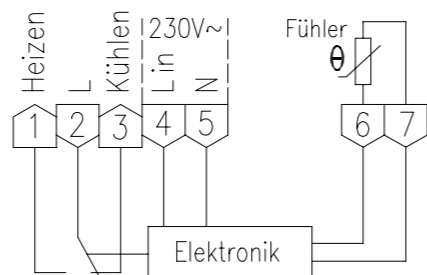
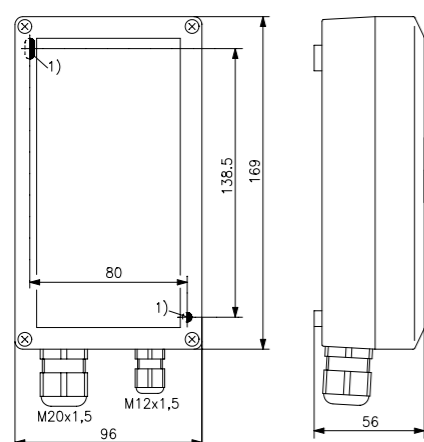
ILLUSTRATIONS

ACCESSORIES	ITEM NO.	FEATURES	EURO/PG
AF-51	G9040420	external temperature sensor	27.10/III
ALF-51	G9050210	contact temperature sensor	30.30/III
BTF2-Y81 / 121-0000	SA140017	Room temperature sensor, surface-mounted	30.10/III
FUFY-81 / 121-0000	SN090201	Room temperature controller, flush-mounted	38.10/III
KF-51	G9031452	Cable temperature sensor with 1.5 m silicone cable	34.10/III
KF-51 / 6	G9031453	Cable temperature sensor with 6 m silicone cable	38.20/III
STF-51	SN080500	Radiation temperature sensor	88.20/III







MECHANICAL HYGROSTATS

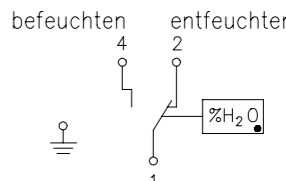

DUCT ASSEMBLY

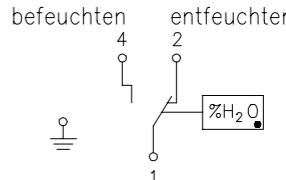
**TECHNICAL DATA**

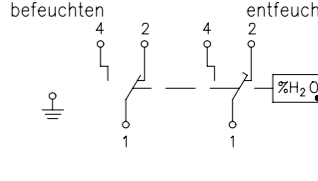
Housing colour:	grey (lower part similar to RAL 7016, upper part similar to RAL 7035)	APPLICATION	Use in ventilation and air-conditioning ducts, climate exposure cabinets and dehumidifiers for controlling and / or monitoring the atmospheric humidity in industrial and agricultural applications. Not suitable for aggressive gases. Max. air speed 8 m / s, with sensor protection FS-HI 15 m / s.
Ambient temperature:	0 to 60 °C		
Permissible atmospheric humidity:	non-condensing		
Operating voltage:	none		
Max. switching current:	15 (8) A		
Min. switching current:	150 mA at 125 VAC		
Max. switching voltage:	230 VAC, 50 Hz (> 24 V only in dry surroundings)		
Min. switching voltage:	24 VAC, 50 Hz		
Switching element:	microswitch		
Switching contact:	toggler, potential-free		
Control range:	30-100% rel. humidity		
Hysteresis:	approx. 5% rel. humidity		
Tolerances:	> 50%: +/- 3.5% relative humidity < 50%: +/- 4% relative humidity		
Electrical connection:	screw-type terminals		
Mounting / attachment:	mounting on air duct or wall mounting using accessory JZ-20-1		
Protection rating:	IP65 front-side		
Protection class:	II		
Safety and EMC:	according to DIN EN 60730		
Sensor:	plastic fibres		

TYPE/IMAGE	ITEM NO.	FEATURES	CIRCUIT DIAGRAM	EURO/PG
	JA010100	Control function: humidifying or de-humidifying Function type: controller external setting, mechanical range setting		250.60/II
	JA010200	Control function: humidifying or de-humidifying Function type: monitor internal setting		242.20/II
	JA010300	Control function: 2 x humidifying or de-humidifying Hysteresis between the stages: adjustable 3-15% rel. humidity Function type: controller external setting, mechanical range setting		316.60/II

**MECHANICAL HYGROSTATS****DUCT ASSEMBLY**

ACCESSORIES/ OPTIONS	ITEM NO.	FEATURES	EURO/PG
JZ-20-1 	E6130144	Wall bracket for HI	24.10/II
FS-HI 	H530975	Sensor protection for HI: finely woven mesh wire, for use at high air speeds of over 8 m/s	18.50/II
FS2-HI 	H531011	PTFE filter for HI: fine sensor protection against dust and contamination	79.20/II

ILLUSTRATIONS

HI-

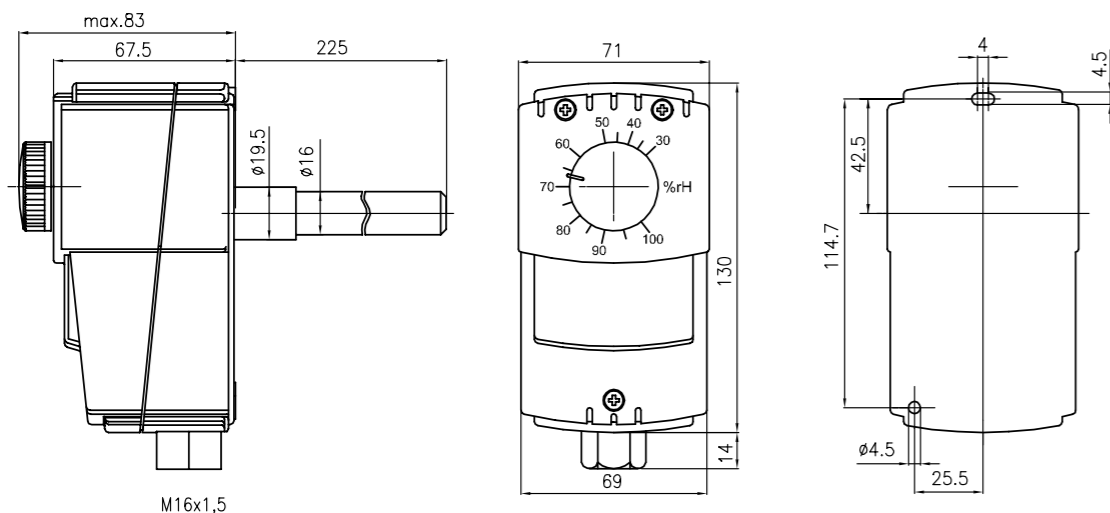
**WIND INDICATOR RELAY JSL-1E****MECHANICAL****TECHNICAL DATA**

Housing colour:	grey (lower part similar to RAL 7016, upper part similar to RAL 7035)	APPLICATION	Monitoring of air flows in ducts, in air supply and air exhausting devices of fans or electrical heat registers.
Ambient temperature:	-40 to +80 °C	<p>The wind indicator relay is set to the minimum switching points at the factory. The switch-on / switch-off values can be increased by turning the inner screw clockwise. Fitting is done in the vertical paddle position from the top in a horizontal pipe / duct.</p>	
Permissible atmospheric humidity:	max. 95% rel. humidity, non-condensing		
Max. medium temperature:	85 °C		
Operating voltage:	none		
Max. switching current:	15 (8) A		
Min. switching current:	150 mA at 24 VAC		
Max. switching voltage:	230 V AC, 50 Hz		
Min. switching voltage:	24 VAC, 50 Hz		
Switching element:	microswitch		
Switching contact:	toggler, potential-free		
Control function:	airflow monitoring		
Hysteresis:	approx. 1 m/s		
Electrical connection:	screw-type terminals		
Mounting / attachment:	mounting on air duct		
Protection rating:	IP65 housing side, IP20 medium side		
Protection class:	I		
Safety and EMC:	according to DIN EN 60730		
Sensor:	wind indicator		
Material (vane):	V2A (1.4301)		
Material (lever):	brass		
Function type:	monitor		
General features:	internal setting		

TYPE	ITEM NO.	MIN. SWITCH-ON VALUE:	MIN. SWITCH-OFF VALUE:	MAX. SWITCH-ON VALUE:	MAX. SWITCH-OFF VALUE:	EURO/PG
JSL-1E	JA070100	2 m/s	1 m/s	9.2 m/s	8 m/s	115.40/II

TYPE	ITEM NO.	FEATURES	EURO/PG
JZ-08	E6150031	spare vane for JSL-1E	23.10/II

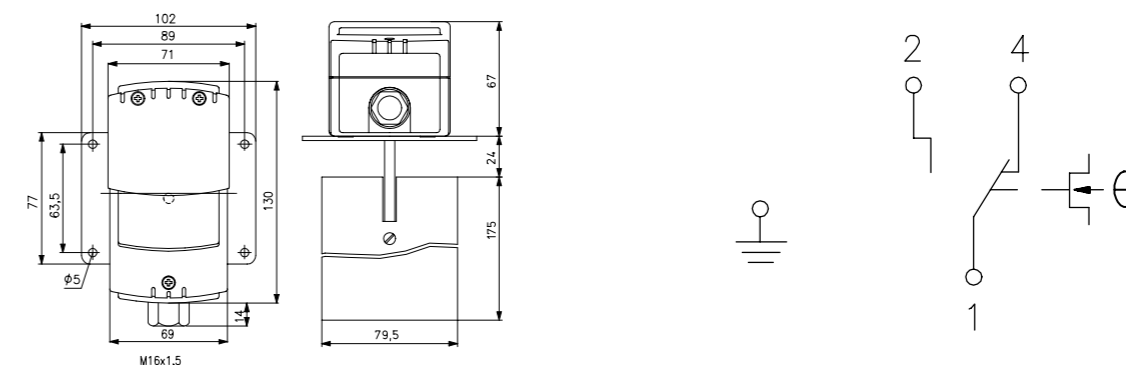
ILLUSTRATIONS

Mounting: The device can be mounted in any alignment, but attention must be paid to the correct direction of flow. When fitting in a vertical duct, the weight of the vane must be balanced at the range screw, which results in changed switching values. Attention: Owing to the changed switching values, at flows near the minimum set value the wind indication relay may not function properly! At air speeds higher than 5 m/s, owing to the danger of breakage, the vane must be cut on the sides where indicated. This increases the minimum switch-off value set at the factory from 1 m/s to 2.5 m/s. A calming path that is 5 times the duct diameter must be provided before and after the assembly location. The scope of delivery includes a seal to be fitted between the duct and the device.

Function: The devices are set to the minimum switch-off value at the factory. A higher value can be selected by turning the range screw to the right. If the flow exceeds the value that has been set, contacts 1–2 close and the corresponding assembly is enabled. If the flow drops below the value that has been set, contacts 1–2 open and contacts 1–4 close.

DIFFERENTIAL PRESSURE SWITCH

JDW-3...10 / JDL-111... 116



JDW-3



JDL-111



JDL-112

TECHNICAL DATA

Housing colour: black
Ambient temperature: -15 to +80 °C
Permissible atmospheric humidity: Max. 95% rel. humidity, non-condensing
Max. sensor temperature: 80 °C
permissible Medium temperature: -15 to +80 °C
Operating voltage: none
Min. switching current: 1 mA
Max. switching voltage: 230 VAC / 50 Hz, 24 VDC
Min. switching voltage: 12 VAC / 50 Hz, 12 VDC
Switching element: microswitch
Switching contact: toggler, gold contact, potential-free
Control function: switches if the pressure is undershot or exceeded
Pressure connection: 6.2 mm
Mounting / attachment: wall mounting
Electrical connection: screw-type terminals
Protection class: II
Protection rating: IP54
Safety and EMC: according to DIN EN 60730
Sensor: pressure membrane
Function type: monitor (JDL-116 A controller)

APPLICATION

Monitoring of overpressure, differential or under-pressure of air and incombustible, non-aggressive gases. Exhaust or fan monitoring or flow monitor for securing electrical heat registers, as filter monitoring, air pressure shortage safeguard, limit value controller.

JDW- ...: Supplied without mounting bracket; can be screwed on directly (with 2 screws).

JDW-...Z: Supplied with attached mounting bracket JZ-10

JDL ...: Supplied with attached mounting bracket JZ-10.

Note: Once the differential pressure switch has connected a voltage > 24 V and a current > 0.1 A, the gold layer at the contacts will have burnt away. Thereafter, the differential pressure switch can only be operated at this or a higher power.

Note: The hose set is not a part of the delivery scope and must be ordered separately.

CONVERSION TABLE PRESSURE

	Pa	kPa	bar	mbar	mmWs
1 Pa =	1	0.001	0.00001	0.01	0.101971
1 kPa =	1,000	1	0.01	10	101.971
1 bar =	100,000	100	1	1,000	10197.1
1 mbar =	100	0.1	0.001	1	10.1971
1 mmWs =	9.80665	0.00980665	0.000980665	0.0980665	1

TYPE	ITEM NO.	CONTROL RANGE	MAX. PRESSURE	HYSTERESIS (dependent on setting range)	FEATURES	EURO / PG
JDW-3	H531002	20–330 Pa	5,000 Pa	approx. 8–20 Pa	Max. switching current: 1.5 (0.4) AAC, 1 (0.2) ADC internal setting	57.00 / II
JDW-3 Z	H531001	20–330 Pa	5,000 Pa	approx. 8–20 Pa	Max. switching current: 1.5 (0.4) AAC, 1 (0.2) ADC internal setting, fixing bracket	63.20 / II
JDW-5	H530996	30–500 Pa	5,000 Pa	approx. 10–25 Pa	Max. switching current: 1.5 (0.4) AAC, 1 (0.2) ADC internal setting	57.00 / II
JDW-5 Z	H531000	30–500 Pa	5,000 Pa	approx. 10–25 Pa	Max. switching current: 1.5 (0.4) AAC, 1 (0.2) ADC internal setting, fixing bracket	63.20 / II
JDW-10	H530997	400–1600 Pa	5,000 Pa	approx. 30–60 Pa	Max. switching current: 1.5 (0.4) AAC, 1 (0.2) ADC internal setting	57.00 / II
JDL-111	H5309098	20–300 Pa	15,000 Pa	approx. 10–15 Pa	Max. switching current: 5 (1) AAC, 1 (0.2) ADC internal setting, silicone-free	63.70 / II
JDL-112	H5309100	40–600 Pa	30,000 Pa	approx. 22–33 Pa	Max. switching current: 5 (1) AAC, 1 (0.2) ADC internal setting, silicone-free	62.40 / II
JDL-115	H5309136	100–1,000 Pa	30,000 Pa	approx. 20–40 Pa	Max. switching current: 5 (1) AAC, 1 (0.2) ADC internal setting, silicone-free	62.40 / II
JDL-116	H530960	250–5,000 Pa	30,000 Pa	approx. 60–150 Pa	Max. switching current: 5 (1) AAC, 1 (0.2) ADC internal setting, silicone-free	62.40 / II
JDL-116 A	H530978	250–5,000 Pa	30,000 Pa	approx. 60–150 Pa	Max. switching current: 5 (1) AAC, 1 (0.2) ADC external setting, silicone-free	70.60 / II

DIFFERENTIAL PRESSURE SWITCH

JDW-3 ... -10 / JDL-111 ... -116

TYPE	ITEM NO.	FEATURES	EURO / PG
JZ-06 / 1	H5309229	connection set with duct connections made of plastic silicon-free, 2 x 90° angles 2 extensions 90 mm, 4 self-tapping screws, 2 m tube (Ø 6 mm outside)	11.60 / II
JZ-10	H5309237	Mounting bracket with screws for JDW-3 / -5 / -10 (Z shape)	6.20 / II
JZ-28	H531012	IP65 cover set, consisting of a cover with pressure compensation element, O-ring and 3 screws, suitable for retrofitting types JDL-111, JDL-112, JDL-115 and JDL-116	64.00 / II

ILLUSTRATIONS

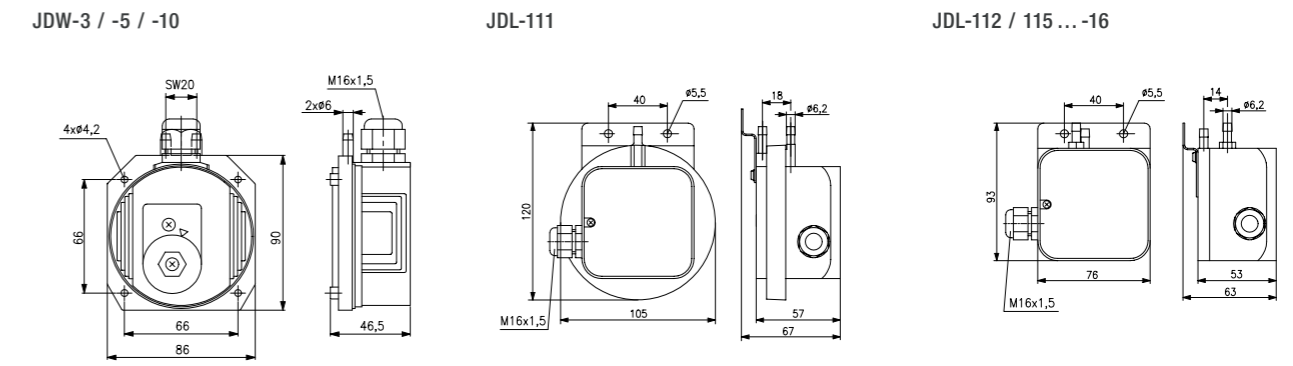

JDW- ... / JDL- ...

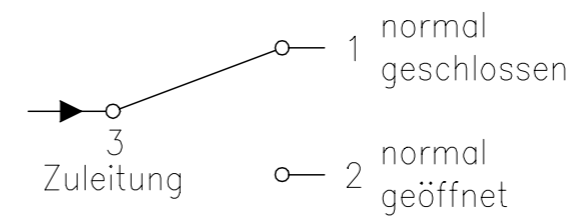

JZ-06 / 1



JZ-10

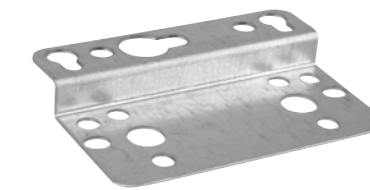

JDL-116 A



JZ-28





AIRFLOW MONITORS, WSERD-XXX.446

ELECTRONIC AIRFLOW MONITORS



TECHNICAL DATA

Rated voltage:	100–240 VAC or 24 V ±10% AC/DC
Rated power consumption:	< 3 VA
Contact:	2 x togglers, potential-free
Switching voltage:	max. 250 VAC
Switching current:	max. 8 A
Electrical connection:	2.5 mm ² (sensor 1.0 mm ²), screw-type terminals
Protection class:	2
Protection rating:	IP65 (housing) / IP54 (sensor), EN 60529
Setting range:	0.2–10 m/s
Operational range:	0.8–10 m/s flow speed
Start delay:	15–120 seconds
Ambient temperature range:	housing (0 to +50 °C) / sensor (–20 to +90 °C)
Transport and storage temperature:	–10 to +75 °C
Permissible atmospheric humidity:	< 95%
Condensation:	permissible (only external)
Overvoltage category (control unit):	2
Rated impulse voltage:	4000 V
Degree of fouling:	2
Material:	housing cover (polycarbonate), bottom part of housing (ABS), sensor (PVC), cable gland (PA6), sensor housing (aluminium with polyamide PA6)

APPLICATION

The WSERD airflow monitors are used for the analysis of airflows and the switching statuses that are generated as a result, for monitoring fans or butterfly valves, for flow-dependent monitoring of humidifiers and electric heat registers in accordance with DIN 57100, part 420 and are used in conjunction with DDC systems.

The measuring system, consists of the sensor and the control unit. Two different models of the measuring system are offered: one for wall mounting (the sensor is connected using a cable) and the WSERD-534.446 for duct mounting (the sensor is permanently connected to the control unit). Sensors and control units are balanced independently of one another, and the wall-mounted model can be replaced with devices that are similar in design.

This device meets the following requirements:

2014/30/EU EMC directives • 2014/35/EU Low Voltage Directive • EN 61326-1:2013 General EMC Requirements • EN 61326-2-3:2013 Immunity for residential/commercial areas • DIN EN 60947-5-1 Low-voltage switchgear and control gear • EN 50581:2012 Restriction of the use of certain hazardous substances

Mounting: performed according to model using suitable screws (WSERD-134.446; not included in the scope of delivery) on even substrate or on the duct using the mounting flange included in the scope of delivery (WSERD-534.446).

TYPE	ITEM NO.	FEATURES	EURO/PG
WSERD-134.446	G8000428	For wall mounting	427.10/III
WSERD-534.446	G8000429	For duct mounting	427.10/III

ILLUSTRATIONS

WSERD-134.446 for wall mounting

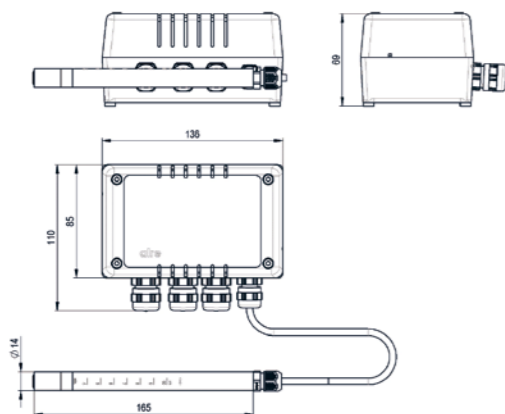

WSERD-534.446 for duct mounting

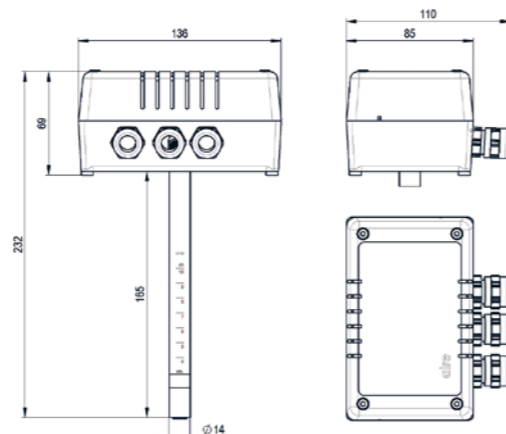

FLOW MONITOR JSF-1 E ... 4 E

MECHANICAL – TÜV-TESTED



TECHNICAL DATA

Housing colour:	grey (lower part similar to RAL 7016, upper part similar to RAL 7035)
Ambient temperature:	–40 to +85 °C
Permissible atmospheric humidity:	Max. 95% rel. humidity, non-condensing
permissible Medium temperature:	120 °C
Operating voltage:	none
Max. switching current:	15 (8) A
Min. switching current:	150 mA at 24 VAC, 50 Hz
Max. switching voltage:	230 V AC, 50 Hz
Min. switching voltage:	24 VAC, 50 Hz
Switching element:	microswitch
Switching contact:	toggler, potential-free
Control function:	switches if the set value is undershot or exceeded
Hysteresis:	depends on the pipe diameter (see the table of switching values)
Electrical connection:	screw-type terminals
Mounting / attachment:	assembly by means of tapered Whitworth pipe thread R1"
Protection rating:	IP65
Protection class:	I
Safety and EMC:	according to DIN EN 60730
Sensor:	flow paddle
Material of paddle:	stainless steel
Function type:	monitor
General features:	internal setting
Accuracy:	+/- 15% of the set value
Test mark / approbation:	JSF-1E / JSF-2E / JSF-3E / JSF-4E TÜV. SW.016-13 JSF-1RE / JSF-2RE TÜV.SW.017-13

APPLICATION

Flow monitoring of liquid media in pipes from 1/2" to 8", for example, oil, cooling and lubricant circuits or as a precaution against a shortage of water.

Assembly: The device can be mounted in any position.

Calming path at least 5 times the pipe diameter before and after the paddle.*

The max. flow can be significantly higher than the maximum setting value of the monitor.

Not approved for drinking water applications.

TÜV test up to 6" or for all diameters

Type-tested by the TÜV according to the 'Flow 100' VdTÜV circular

TYPE	ITEM NO.	PIPE	MEDIUM	FEATURES	EURO/PG
JSF-3 E	JA060500	1/2"	normal	material of carrier: brass max. pressure: 5 bar attached T-piece, grey iron	201.90/II
JSF-4 E	JA060600	3/4"	normal	material of carrier: brass max. pressure: 5 bar attached T-piece, grey iron	210.50/II
JSF-1 E	JA060100	1"–8"	normal	material of carrier: brass max. pressure: 8 bar	190.00/II
JSF-1 RE	JA060200	1"–8"	normal	material of carrier: brass max. pressure: 5 bar reduced switching values**	190.00/II
JSF-2 E	JA060300	1"–8"	aggressive ***	material of carrier: V4A max. pressure: 13 bar	481.60/II
JSF-2 RE	JA060400	1"–8"	aggressive ***	material of carrier: V4A max. pressure: 5 bar reduced switching values**	481.60/II



FLOW MONITOR JSF-1 E ... 4 E

MECHANICAL – TÜV-TESTED

ACCESSORIES	ITEM NO.	FEATURES	EURO/PG
JZ-09	E6140170	Spare paddles (each 4 units) from 1" to 8"	23.10/II

* for 1" = paddle 1
 for 2" = paddle 1 and 2
 for 3" to 8" = Paddle 1, 2 and 3;

If reduced flow values (marked in the table under the column pipe with added letters Z) are to be reached, paddle 4 should be used as follows:
 for 4" = Paddle 1, 2, 3, 4 (shorten Paddle 4 to 92 mm)
 for 5" = Paddle 1, 2, 3, 4 (shorten Paddle 4 to 117 mm);
 for 6" = Paddle 1, 2, 3, 4 (shorten Paddle 4 to 143 mm);
 for 7" and 8" = Paddle 1, 2, 3, 4 (Paddle 4 not shortened)

** device types for low flow volume (see switching value table) "RE"

*** medium aggressive: all parts of the current monitor touching the medium are made of V4A

ILLUSTRATIONS

JSF-E / RE

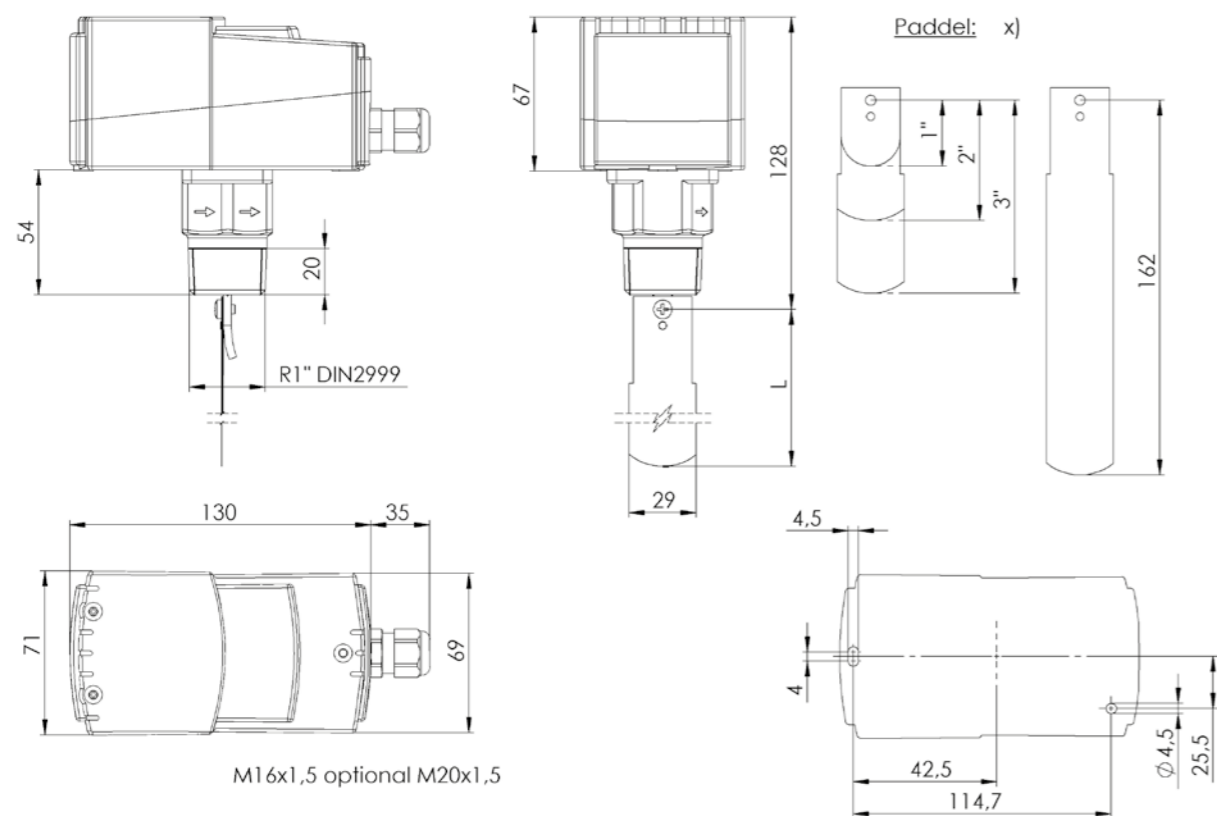

JSF-E / RE

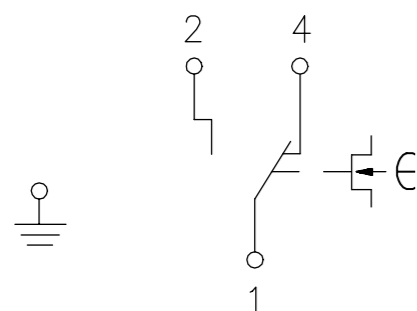

DN nominal width	Pipe thread inches
6	1/8"
8	1/4"
10	3/8"
15	1/2"
20	3/4"
25	1"
32	1 1/4"
40	1 1/2"
50	2"
65	2 1/2"
80	3"
100	4"
125	5"
150	6"



FLOW MONITOR JSF-1 E ... 4 E

MECHANICAL – TÜV-TESTED

SWITCHING VALUE TABLE IN m³/h FOR JSF-1 E/2 E/1 RE/2 RE

TYPE	PIPE DIAMETER	MIN. SETTING (FACTORY SETTING)		MAX. SETTING	
		OFF	ON	OFF	ON
E	1"	0.55	0.86	2.00	2.10
RE	1"	0.19	0.57	1.00	1.10
E	1 1/4"	0.82	1.30	2.80	3.00
RE	1 1/4"	0.24	0.90	1.40	1.60
E	1 1/2"	1.10	1.70	4.00	4.20
RE	1 1/2"	0.50	1.20	1.90	2.20
E	2"	2.10	3.20	7.30	7.80
RE	2"	0.90	2.30	3.60	4.10
E	2 1/2"	2.80	4.30	9.80	10.50
RE	2 1/2"	1.20	3.10	4.90	5.50
E	3"	4.00	6.10	13.80	14.70
RE	3"	2.10	4.90	7.40	8.20
E	4"	10.40	15.40	32.00	33.90
RE	4"	4.90	11.30	17.10	19.10
E	4" Z	7.00	10.50	21.70	23.10
RE	4" Z	3.30	7.70	11.60	13.00
E	5"	20.80	30.60	63.50	67.30
RE	5"	9.70	22.40	34.00	37.90
E	5" Z	10.70	15.80	33.30	34.70
RE	5" Z	5.00	11.50	17.50	19.60
E	6"	29.20	43.00	89.10	94.50
RE	6"	13.60	31.50	47.60	53.20
E	6" Z	13.10	19.30	39.90	42.40
RE	6" Z	6.10	14.10	21.40	23.90
E	8"	72.60	85.10	165.70	172.50
RE	8"	25.70	59.60	90.10	100.70
E	8" Z	38.60	46.50	90.80	94.20
RE	8" Z	21.70	36.50	55.30	61.80

When there is a 'Z' (=additional paddle) in the 'Pipe' column, the long paddle 4 included in the delivery must be used in addition to the 3 factory-installed paddles.

SWITCHING VALUE TABLE IN l/h FOR JSF-3 E/ -4 E

3 E	1/2	174	480	846	948
4 E	3/4	138	408	768	858

The accuracy of the specified values depends on the actual diameter of the pipe, the actual reduction in the extra paddle and the flow monitor's installation depth.

The devices are set to the minimum switch-off value at the factory. By turning the inner adjusting screw in a clockwise direction, you can set a higher deactivation value. The actual flow quantity must in any case be higher than the one specified in the switch table or the switch-on value, but there is no upper limit. The values specified apply to volume-related mass (density) of water. If the flow drops below the value that has been set, contacts 1 and 2 open and contacts 1 and 4 close.



FLOW MONITOR JSW WITH DEVICE PLUG



TECHNICAL DATA

Housing colour:	black
Material of paddle:	stainless steel
material of carrier:	nickel-plated brass
Ambient temperature:	-20 to +70 °C
Permissible atmospheric humidity:	max. 95% rel. humidity, non-condensing
max. pressure:	25 bar
permissible Medium temperature:	110 °C
Operating voltage:	none
Max. switching current:	5 A
Min. switching current:	100 mA at 24 VAC, 50 Hz
Max. switching voltage:	230 V AC, 50 Hz
Min. switching voltage:	24 VAC, 50 Hz
Switching element:	microswitch
Switching contact:	toggler, potential-free
Control function:	switches if the set value is undershot or exceeded
Electrical connection:	4-pin plug according to DIN EN 175301-803 (previously DIN 43650 - A/ISO 4400)
Mounting / attachment:	Union nut G 3/8" on soldering socket (for soldering into a standard copper T-piece with outlet 1/2") or T-piece
Protection rating:	IP65
Protection class:	II
Safety and EMC:	according to DIN EN 60730
Sensor:	flow paddle
Function type:	monitor
General features:	internal setting
Accuracy:	+/- 15% of the set value (switching values are only accurate if the flow monitor has been installed in our T-piece. If copper T-pieces are used, the switching values will increase.)

APPLICATION

Monitoring small and medium, non-aggressive quantities of liquid in pipes with small diameters 1/2" to 1".

Assembly: Vertical in a horizontal pipe. Calming path at least 5 times the pipe diameter before and after the paddle.

Not approved for drinking water applications.

Brass union nut G 3/4" with O-ring and brazing spout for brazing in a standard copper T-piece with outlet 1/2" included in the scope of delivery.

TYPE	ITEM NO.	PIPE	DN	MAX.	SWITCHING POINT DROPPING*	SWITCHING POINT RISING	ΔL/MIN	EURO/PG
JSW-1/2	H530944	1/2"	15	20 l/min	5.0–6.5 l/min	5.5–7.0 l/min	0.5	159.90 / III
JSW-3/4	H530945	3/4"	20	40 l/min	7.0–9.5 l/min	9.0–11.0 l/min	2.0	159.90 / III
JSW-1	H530946	1"	25	60 l/min	13.5–16.5 l/min	17.0–20.5 l/min	3.5	159.90 / III



T-PIECE (NICKEL-PLATED BRASS):

T-piece 1/2"	H530957	24.80 / III
T-piece 3/4"	H530951	27.90 / III
T-piece 1"	H530953	30.20 / III



FLOW MONITOR JSW WITH DEVICE PLUG

ILLUSTRATIONS

JSW

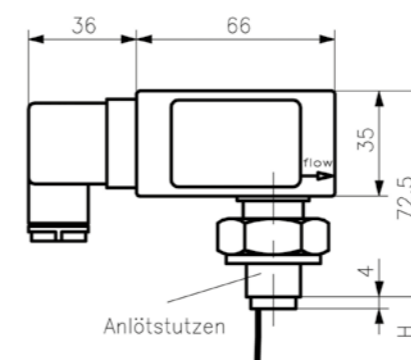
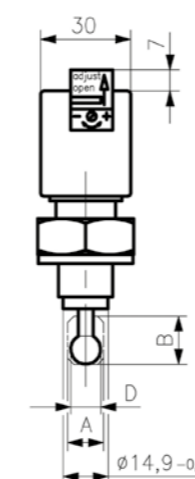

Typ	H	D	A	B
JSW1/2"	18,5	10	-	-
JSW3/4"	27,0	-	12	16
JSW1"	27,0	-	12	16

JSW

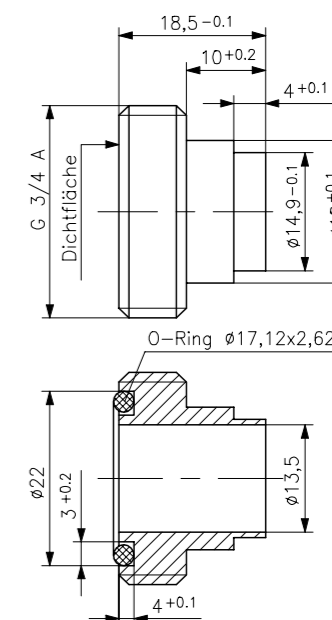

JSW

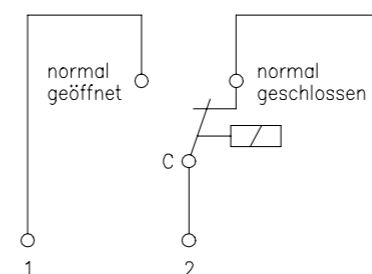

The device works according to the principle of a spring-loaded paddle with magnetic control of a micro-switch. When in rest position or if the switch-off value is undershot (= 'dropping switching point'), contacts 2 and 3 are closed and can be used as signal contacts. Upon reaching the upper switching value (= switch-on value or 'switching point rising'), the contact changes and 2 to 1 are closed. If used as a water shortage safeguard, for example, a pump can be switched on with these contacts. The actual flow quantity must in any case be higher than the switch-on value, but there is no upper limit.

The switching points given in the table apply to flow monitors with an attached T-piece and a water temperature of 20 °C in a horizontal pipe. The devices are set to the minimum switch-off value at the factory, but can be adapted to an existing plant. To that end, the cover of the setting screw on the front side, which is designed so that it cannot be lost, is pushed up in the direction of the arrow and the setting screw is rotated by a maximum of 7 revolutions in the plus direction. With a switching value range of, for example, 13–16.5 l/min, a setting range of 3.5 l/min is obtained. With a total of seven permissible screw revolutions, this gives a change of 0.5 l/min per screw revolution.



UNIVERSAL PRESSURE SWITCH JPS

WITH 2 SWITCHING RANGES



TECHNICAL DATA

Housing colour and material:

steel plate, grey powder-coated
Lower part = steel plate (galv. Zn bl)

Membrane:

polyester fabric, coated on both sides

Ambient temperature:

max. 55 °C

Medium temperature:

-30 to +80 °C

Switch-off point:

0.6-2.5 bar

Protection rating:

IP10 according to DIN 40050

Switching capacity:

2A (2) 230 V – in accordance with
DIN EN 61058-1

Contact:

changeover switch

Pressure ranges (setting ranges) and differentials:

(a) in the normal range:

Switching range 1:
can be set from 1.0 to 4.0 kp/cm²
Differential can be set from 0.7 to 1.5 kp/cm²
Switching range 2:
can be set from min. 0.3 to max. 1.0 kp/cm²
beneath the first range
Fixed differential 0.3 kp/cm²

(b) with increased pressure range:

Switching range 1:
can be set from 1.3 to 6.0 kp/cm²
Differential can be set from 0.7 to
1.5 kp/cm²
Switching range 2:
can be set from min. 0.3 to max. 1.0 kp/cm²
beneath the first range
Fixed differential 1.3 kp/cm²

APPLICATION

The JPS is a universal pressure switch with two switching ranges and is suitable for oil, water and air.

It can also be used as a controller for domestic heating oil supply systems, pressure boosting systems, oil pumps and so on.

All devices have changeover contacts

The starter button causes the second switching range to be bridged (if it functions as a safety range). The red indicator light remains illuminated until the accumulated pressure has reached the first switching range

TYPE	ITEM NO.	MEASUREMENT RANGES	FEATURES	EURO/PG
JPS-1	E6160006	2 switching ranges, with starter button and indicator light	Connection adapters for 10-mm immersion sleeve	261.00/II
JPS-3	E6160020	2 switching ranges, with starter button and indicator light, alternate switch-on point	Hexagonal connection-adapters SW17 with 1/4" internal thread	317.80/II
JPS-3 B	E6160044	2 switching ranges, with starter button and indicator light, alternate switch-on point	Connection adapters for 10-mm immersion sleeve	259.10/II
JPS-4	E6160057	2 switching ranges, with starter button and indicator light, for the higher pressure range	Connection adapters for 10-mm immersion sleeve	257.60/II
JPS-13	E6160119	2 switching ranges, with starter button and indicator light	Hexagonal connection-adapters SW17 with 1/4" internal thread	278.00/II

SWITCHING POINTS (FACTORY SETTING)

JPS TYPE	1	3	3 B	4	13
Lower switch-off point	1.25	1.4	1.3	1.25	0.6
Switch-on point (tolerance / +- 0.02 bar)	1.6	1.8	1.8	1.6	1
Switch-off point (tolerance / +- 0.02 bar)	2.5	2.5	2.9	2.5	2.5

ILLUSTRATIONS

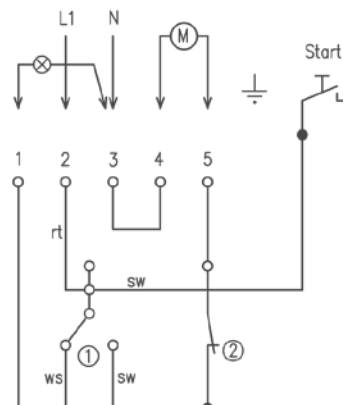
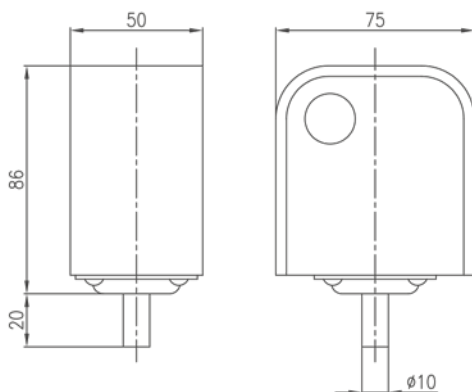

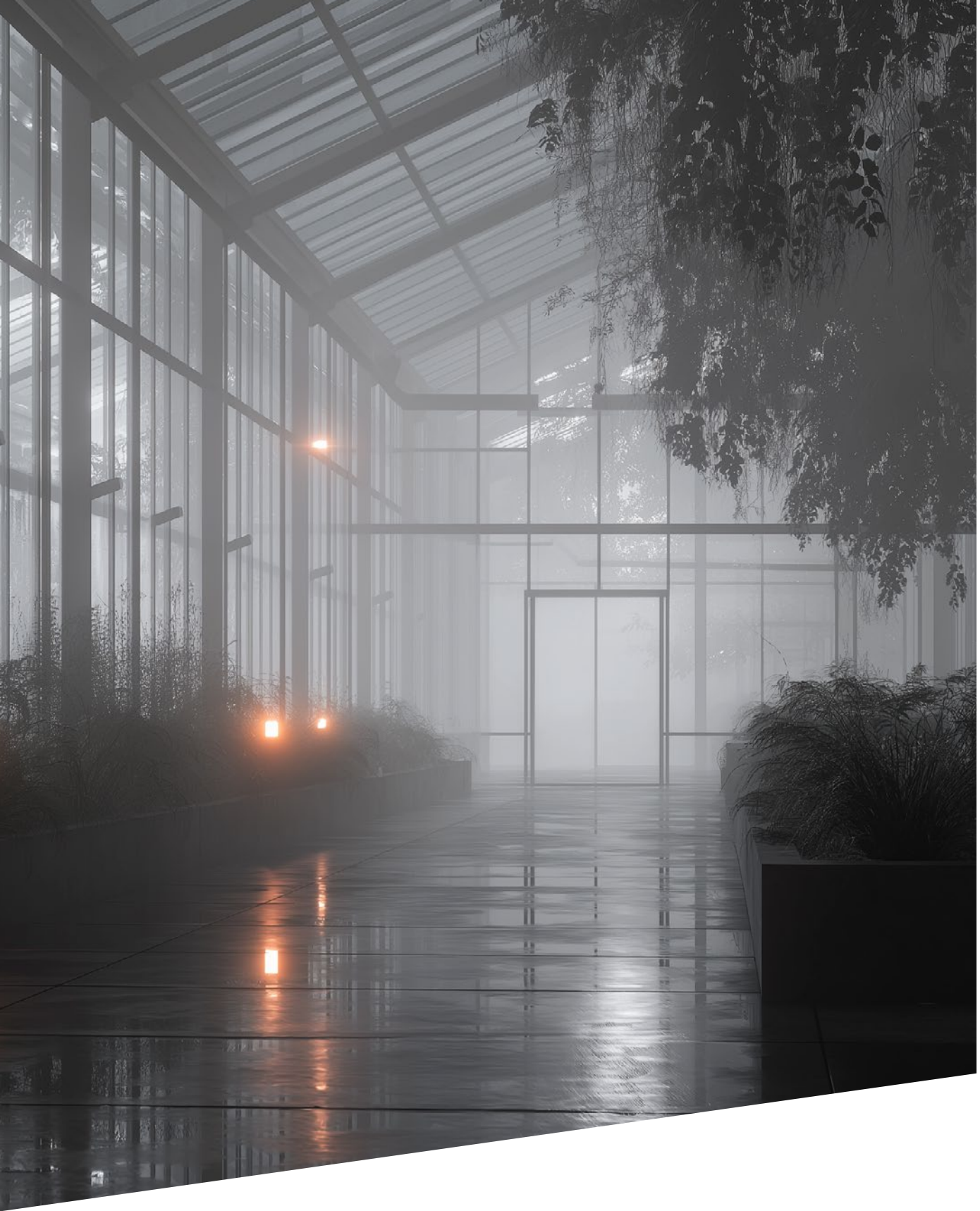

SENSOR TECHNOLOGY

PRECISE AND RELIABLE



ALRE SENSOR TECHNOLOGY, **MEASURE PRECISELY,** CONTROL INTELLIGENTLY.



TEMPERATURE

Room temperature sensor (surface-mounted / flush mounted) – passive	210
Outdoor temperature sensor – passive	213
Sleeve temperature sensors / cable temperature sensors	215
Contact temperature sensors – passive	217
Pendulum temperature sensors / radiation temperature sensors	218
Assembly-type duct sensors – passive	220
Industrial assembly type duct sensors – (Form B) passive	221

DIFFERENTIAL PRESSURE

Differential pressure transducers (air)	222
---	-----

APPLICATION EXAMPLES:

- + Temperature measurement in residential and business spaces, outdoor areas, surface temperatures (contact sensors) in liquid and gaseous media, such as in pipelines and air ducts
- + Pressure measurement in liquid and gaseous media, for example in hydraulics, pneumatics, mechanical and plant engineering, process technology, ventilation or air conditioning applications, clean room technology, fine draft measurement
- + Temperature measurement in rooms or ducts
- + Outdoor temperature measurement, for example in refrigeration, air conditioning and ventilation systems, clean room technology, greenhouses, medical rooms, meteorology



ROOM TEMPERATURE SENSOR, FLUSH-MOUNTED FUF



RADIATION TEMPERATURE SENSOR STF



EXTERNAL TEMPERATURE SENSOR



ROOM TEMPERATURE SENSOR, SURFACE-MOUNTED, ULTRA-SLIM

Our range of sensor technology products is designed to make your life both safer and more convenient. These sensors efficiently collect vital physical data from the environment, including temperature, humidity, and pressure. They then convert this data into electrical signals, which are seamlessly integrated with intelligent control systems. This process ensures accurate interpretation and response, leading to precise and optimal control of your environment.

alre sensor technology: the basis of safety and comfort.

ROOM TEMPERATURE SENSOR – SURFACE-MOUNTED BTF2

SURFACE-MOUNTED ‘ULTRA-THIN’ – DESIGN BERLIN 1000, FOR MEASURING THE TEMPERATURE IN DRY ROOMS



TECHNICAL DATA

Design:	Berlin 1000
Housing colour:	pure white, similar to RAL 9010
Housing material:	ABS plastic
Ambient temperature:	-10 to +50 °C
Permissible atmospheric humidity:	max. 95% rel. humidity, non-condensing
Electrical connection:	Screw-type terminals 0.33 mm ² to 1.5 mm ² only at protective low voltage max. 30 VAC / 42 VDC
Max. measurement current:	< 1 mA
Extendable sensor wire:	depending on the cross-section of the conductor and the sensor unit type
Tolerances:	PT100/PT1000 DIN EN 60751 B
Mounting / attachment:	surface / wall mounting (4-hole assembly on flush-mounted socket)
Protection rating:	IP30
Protection class:	III
Safety and EMC:	according to DIN EN 60730
Sensor characteristic curves:	the sensor characteristic curves can be found in the ‘Miscellaneous’ section

APPLICATION

Temperature measurement in living spaces and office spaces.

Assembly and wiring of the lower part can take place separately, surface-mounted or on a switch socket Ø 60 mm by means of socket screws.

Please follow the EMC directives. Avoid parallel routing with mains voltage-bearing wires, or use shielded wires.

SENSOR	TYPE	ITEM NO.	EURO/PG
PT-100	BTF2-P100-0000	SA140000	30.10/III
PT-1000	BTF2-P1000-0000	SA140001	30.10/III
NTC 2K25 ‘Sensor 0’	BTF2-C225-0000	SA140013	30.10/III
NTC 47K ‘Sensor 2’	BTF2-C47-0000	SA140014	30.10/III
NTC 8K ‘Sensor 3’	BTF2-C08-0000	SA140015	30.10/III
NTC 10K ‘Sensor 4’	BTF2-C10-0000	SA140006	30.10/III
NTC 2K ‘Sensor 8’	BTF2-C02-0000	SA140016	30.10/III
KTY 81-121 ‘Sensor 51’	BTF2-Y81 / 121-0000	SA140017	30.10/III
KTY 11-7 ‘Sensor 57’	BTF2-Y11 / 7-0000	SA140018	30.10/III

ACCESSORIES	ITEM NO.	FEATURES	EURO/PG
JZ-21	MN990006	Adapter frame for mounting room temperature sensors of the Berlin 1000 series in flush-mounted sockets up to 80 x 80 mm	5.60/I

ILLUSTRATIONS

Berlin 1000

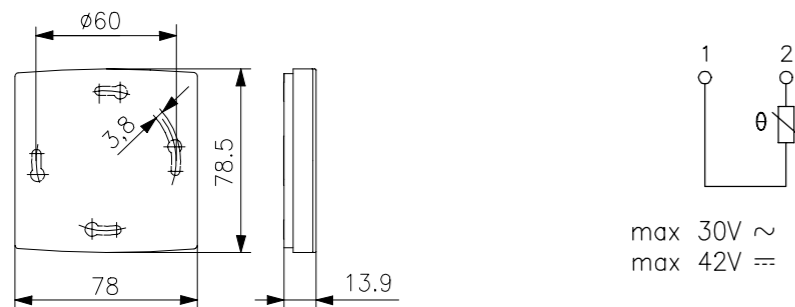

max 30V ~
max 42V =

ROOM TEMPERATURE CONTROLLER – FLUSH-MOUNTED FUF

FOR MEASURING THE TEMPERATURE IN DRY ROOMS



TECHNICAL DATA

Design:	Berlin flush-mounted
Housing colour:	pure white, similar to RAL 9010
Housing material:	PC plastic
Ambient temperature:	-10 to +50 °C
Permissible atmospheric humidity:	max. 95% rel. humidity, non-condensing
Electrical connection:	Screw-type terminals 0.5 mm ² to 1.5 mm ² only to safety extra low voltage max. 30 VAC / 42 VDC
Max. measurement current:	< 1 mA
Extendable sensor wire:	depending on the cross-section of the conductor and the sensor unit type
Tolerances:	PT100/PT1000 DIN EN 60751 B
Mounting / attachment:	in a flush-mounted socket, can be adapted to fit virtually any surface switch range. 50 x 50 mm adaptable
Protection rating:	IP30
Protection class:	III
Safety and EMC:	according to DIN EN 60730
Sensor characteristic curves:	the sensor characteristic curves can be found in the ‘Miscellaneous’ section

APPLICATION

Temperature measurement in living spaces and office spaces.

The room temperature sensor with 50 x 50-mm cover can be integrated into almost all switch ranges by means of an insert frame. (Frames are not a part of the delivery scope.) For integration examples, see the ‘Heating technology’ section.

Please follow the EMC directives. Avoid parallel routing with mains voltage-bearing wires, or use shielded wires.

SENSOR	TYPE	ITEM NO.	SURFACE FINISH	EURO/PG
PT-100	FUFP 100-0000	SN090000	glossy	38.10/III
PT-1000	FUFP 1000-0000	SN090001	glossy	38.40/III
NTC 2K25 ‘Sensor 0’	FUFC 225-0000	SN090197	glossy	38.10/III
NTC 47K ‘Sensor 2’	FUFC 47-0000	SN090198	glossy	38.10/III
NTC 8K ‘Sensor 3’	FUFC 08-0000	SN090199	glossy	38.10/III
NTC 10K ‘Sensor 4’	FUFC 10-0000	SN090005	glossy	38.10/III
NTC 2K ‘Sensor 8’	FUFC 02-0000	SN090200	glossy	38.10/III
KTY 81-121 ‘Sensor 51’	FUFY 81 / 121-0000	SN090201	glossy	38.10/III
KTY 11-7 ‘Sensor 57’	FUFY 11 / 7-0000	SN090202	glossy	38.10/III

ACCESSORIES	ITEM NO.	FEATURES	EURO/PG
JZ-090.900	VV000025	alre frame ‘Berlin’ for all flush-mounted controllers and sensors with 50 x 50-mm pure white cover, glossy, like RAL 9010	4.80/I

ROOM TEMPERATURE CONTROLLER – FLUSH-MOUNTED FUF FOR MEASURING THE TEMPERATURE IN DRY ROOMS

ILLUSTRATIONS

FUF with alre frame 'Berlin'

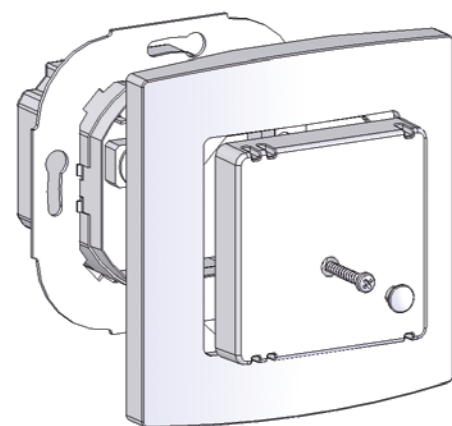

Dimension drawing RUF

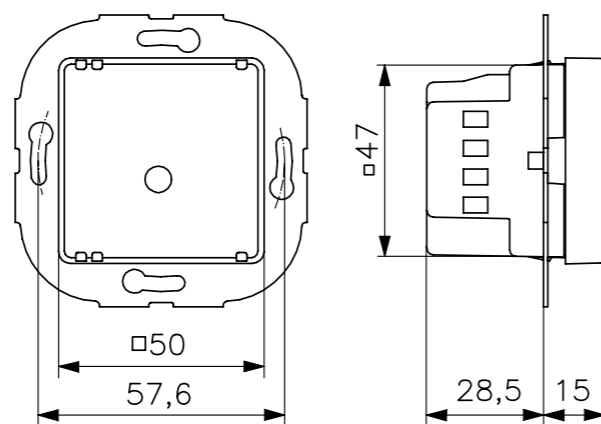

FUFxx-0000

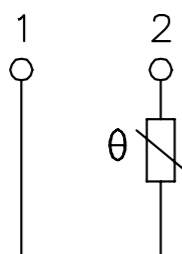

OUTDOOR TEMPERATURE SENSOR AF WITH PASSIVE OUTPUT. AF – OUTDOOR TEMPERATURE SENSOR WITH INSIDE SENSOR

TECHNICAL DATA

Housing colour: pure white, similar to RAL 9010
Housing material: PA plastic (30% GF reinforced)
Ambient temperature: -30 to +70 °C
Permissible atmospheric humidity: max. 95% rel. humidity, non-condensing
Electrical connection: screw-type terminals 0.14 mm² up to 2.5 mm² only at protective low voltage max. 30 VAC/42 VDC
Max. measurement current: < 1 mA
Extendable sensor wire: depending on the cross-section of the conductor and the sensor unit type PT100/PT1000 DIN EN 60751 B
Tolerances: surface/wall mounting
Mounting / attachment: IP65
Protection class: III
Safety and EMC: according to DIN EN 60730
Sensor characteristic curves: the sensor characteristic curves can be found in the 'Miscellaneous' section

APPLICATION

The AF outdoor temperature sensors are used for temperature measurement in the outdoors, in damp environments, in cold storage rooms and greenhouses as well as in industrial applications and are specially protected against dust and moisture. If there is direct incident sunlight on the sensor housing, the use of a sun shade is recommended.



Please follow the EMC directives, avoid parallel routing with mains voltage-bearing wires, or use shielded wires.

SENSOR	TYPE	ITEM NO.	EURO/PG
PT 100	AFP 100	G9040010	27.10/III
PT 1000	AFP 1000	G9040020	27.10/III
NTC 2K25 'Sensor 0'	AF-0	G9040360	27.10/III
NTC 1K 'Sensor 1'	AF-1	G9040370	27.10/III
NTC 47K 'Sensor 2'	AF-2	G9040380	27.10/III
NTC 8K 'Sensor 3'	AF-3	G9040390	27.10/III
NTC 10K 'Sensor 4'	AF-4	G9040400	27.10/III
NTC 50K 'Sensor 5'	AF-5	G9040561	27.10/III
NTC 2K 'Sensor 8'	AF-8	G9040410	27.10/III
KTY 81-121 'Sensor 51'	AF-51	G9040420	27.10/III
KTY 11-7 'Sensor 57'	AF-57	G9040681	27.10/III

ACCESSORIES	ITEM NO.	FEATURES	EURO/PG
S protection 01	G9990170	Ball impact guard, sun and rain protection; 150 x 90 x 47 mm; stainless steel V4A 1.4571	40.00/III

ILLUSTRATIONS

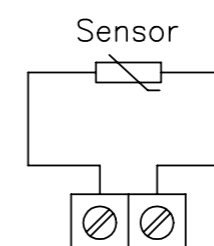
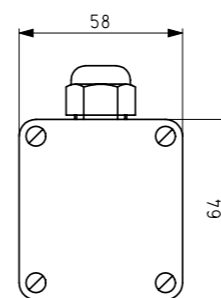

S protection 01

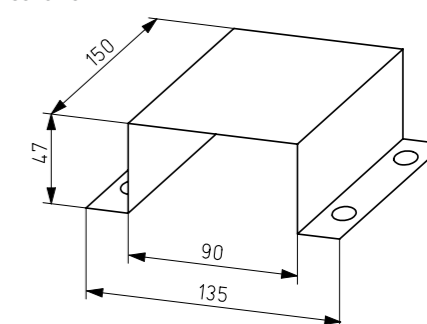

OUTDOOR TEMPERATURE SENSORS AFH WITH PASSIVE OUTPUT

AFH ... OUTDOOR TEMPERATURE SENSOR WITH SLEEVE LEAD-OUT



TECHNICAL SPECIFICATIONS

Housing colour:	pure white, similar to RAL 9010
Housing material:	PA plastic (30% GF reinforced)
Operating voltage (active):	24 VDC
Ambient temperature:	-30 to +70 °C
Permissible atmospheric humidity:	max. 95% rel. humidity, non-condensing
Max. measurement current (passive):	< 1 mA
Electrical connection:	Screw-type terminals 0.14 mm ² to 2.5 mm ² only at protective low voltage, max. passive output: 30 VAC / 42 V DC
Sensor wire extendable:	depending on the cross-section of the conductor and the sensor unit type
Tolerances:	PT100/PT1000 DIN EN 60751 B
Mounting/attachment:	surface / wall mounting
Protection rating:	IP65
Protection class:	III
Safety and EMC:	according to DIN EN 60730

APPLICATION

The outdoor temperature sensors are used for temperature measurement in the outdoors, in damp room applications, in cold storage rooms and greenhouses as well as in industrial applications and are specially protected against dust and moisture. Owing to the external sensor sleeve, this outdoor sensor has a very good actuation response to temperature changes. If there is direct incident sunlight on the sensor, the use of a sun shade is recommended.

Please follow the EMC directives, avoid parallel routing with mains voltage-bearing wires, or use shielded wires.

SENSOR	TYPE	ITEM NO.	EURO/PG
PT 100	AFHP 100	G9040160	47.00/III
PT 1000	AFHP 1000	G9040170	47.00/III
NTC 10K 'Sensor 4'	AFHC 10	G9040220	47.00/III

ILLUSTRATIONS

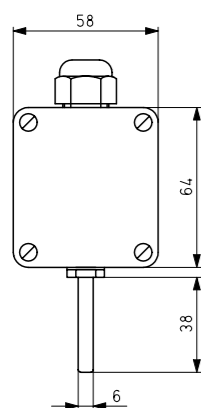

SLEEVE TEMPERATURE SENSORS HF

HF ... / P SLEEVE TEMPERATURE SENSOR WITH PVC CABLE

HF ... / S SLEEVE TEMPERATURE SENSOR WITH SILICONE CABLE



TECHNICAL DATA (HF.../P AND HF.../S)

Sensor dimensions:	Ø 6 mm x 45 mm
Sensor sleeve material:	V2A (1.4301)
Permissible atmospheric humidity:	max. 95% relative humidity, non-condensing
Max. measurement current:	< 1 mA
Electrical connection:	only to safety extra low voltage max. 30 VAC / 42 VDC
Connecting cable:	1 m, 2 x 0.5 mm ² (HFP 100/S/6 m: 6 m, 2 x 0.5 mm ²)
Extendable sensor wire:	depending on the cross-section of the conductor and the sensor unit type
Tolerances:	PT100/PT1000 DIN EN 60751 B
Mounting/attachment:	in immersion sleeve, protective coil, on pipe etc.
Protection rating:	IP65, moisture-impregnable burnishing
Protection class:	III
Safety and EMC:	according to DIN EN 60730
Sensor characteristic curves:	the sensor characteristic curves can be found in the 'Miscellaneous' section
Immersion sleeves:	Immersion sleeves can be found in the 'Miscellaneous' section.

APPLICATION

The HF sleeve sensors are used for temperature measurement in liquid or gaseous media. Thanks to the moisture-impermeable burnishing, the sleeve sensor is particularly protected against moisture and dust.

If used in liquid media, integration in an immersion sleeve is necessary.

Please follow the EMC directives, avoid parallel routing with mains voltage-bearing wires, or use shielded wires.

SENSOR	TYPE	ITEM NO.	FEATURES	EURO/PG
PT 100	HFP 100/P	G9030010	Sensor wire PVC, -35 to +105 °C	19.60/III
PT 1000	HFP 1000/P	G9030020	Sensor wire PVC, -35 to +105 °C	19.60/III
NTC 10K	HFC 10/P	G9030070	Sensor wire PVC, -30 to +105 °C	19.60/III

SENSOR	TYPE	ITEM NO.	FEATURES	EURO/PG
PT 100	HFP 100/S	G9030140	Sensor wire, silicone, -50 to +150 °C	27.20/III
PT 100	HFP 100/S/6 m	G9030411	Sensor wire, silicone, -50 to +150 °C	39.00/III
PT 1000	HFP 1000/S	G9030150	Sensor wire, silicone, -50 to +150 °C	27.20/III
Ni 1000	HFN 1000/S	G9030160	Sensor wire, silicone, -50 to +150 °C	30.30/III
NTC 10K	HFC 10/S	G9030200	Sensor wire, silicone, -30 to +150 °C	27.20/III

ILLUSTRATIONS

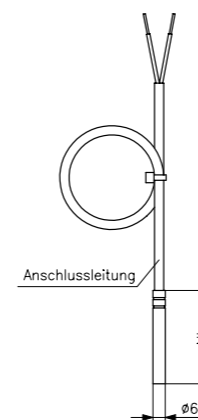

CABLE TEMPERATURE SENSOR KF (REMOTE SENSOR FOR ALRE STANDARD DEVICES, FOR EXAMPLE, ITR79, ETC.)



TECHNICAL DATA (HF.../P AND HF.../S)

Sensor dimensions:	see dimension diagram
Sensor sleeve material:	V4A (1.4571)
Permissible atmospheric humidity:	max. 95% rel. humidity, non-condensing
Max. measurement current:	< 1 mA
Electrical connection:	only at safety extra-low voltage max. 30 V AC / 42 V DC KF-100-4 and KF-100/6-4 4-wire
Sensor wire extendible up to:	depending on the cross-section of the conductor and the sensor unit type
Tolerances:	PT100/PT1000 Class B
Mounting/attachment:	in immersion sleeve, protective coil, on pipe etc.
Protection rating:	IP 67
Protection class:	III
Sensor characteristic curves:	the sensor characteristic curves can be found in the 'Miscellaneous' section
Accessories:	Immersion sleeves / protection coils can be found under Miscellaneous
Sensor characteristic curves:	the sensor characteristic curves can be found in the 'Miscellaneous' section
Immersion sleeves:	Immersion sleeves can be found in the 'Miscellaneous' section.

APPLICATION

For temperature measurement of liquid media by integrating in immersion sleeves (TH/NTH). For temperature measurement of air and non-aggressive gases in the air duct by integration in a protection coil (SW-200, see the 'Accessories / Miscellaneous' section).

Please follow the EMC directives, avoid parallel routing with mains voltage-bearing wires, or use shielded wires.

SENSOR	TYPE	ITEM NO.	FEATURES	EURO/PG
'Sensor 0' (NTC 2 K 25)	KF-0	G9031441	Wire PE, 1.5 m, -35 to +100 °C	31.40/III
'Sensor 1' (NTC 1K)	KF-1	G9031442	Wire PE, 1.5 m, -35 to +100 °C	31.40/III
'Sensor 2' (NTC 47 K)	KF-2	G9031446	Wire PE, 1.5 m, -35 to +100 °C	31.40/III
'Sensor 3' (NTC 8 K)	KF-3	G9031447	Wire PE, 1.5 m, -35 to +100 °C	31.40/III
'Sensor 4' (NTC 10 K)	KF-4	G9031449	Wire PE, 1.5 m, -35 to +100 °C	31.40/III
'Sensor 4' (NTC 10 K)	KF-4/6	G9031450	Wire PE, 6 m, -35 to +100 °C	33.40/III
'Sensor 5' (NTC 50 K)	KF-5	G9031451	Wire PE, 1.5 m, -35 to +100 °C	31.40/III
'Sensor 51' (KTY 81-121)	KF-51	G9031452	Wire silicone, 1.5 m, -50 to +150 °C	34.10/III
'Sensor 51' (KTY 81-121)	KF-51/6	G9031453	Wire silicone, 6 m, -50 to +150 °C	38.20/III
'Sensor 57' (KTY 11-7)	KF-57	G9031454	Wire PE, 1.5 m, -35 to +100 °C	31.40/III
PT-100	KF-100-4	G9031443	Wire silicone, 1.5 m, -50 to +180 °C	39.90/III
PT-100	KF-100/6-4	G9031444	Wire silicone, 6 m, -50 to +180 °C	46.20/III
PT-1000	KF-1000	G9031445	Wire silicone, 1.5 m, -50 to +180 °C	32.30/III

ILLUSTRATIONS

KF

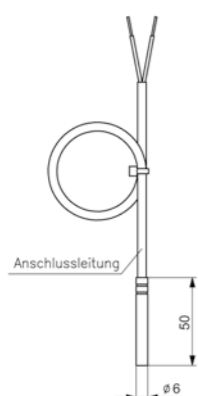

CONTACT TEMPERATURE SENSOR ALF



TECHNICAL DATA

Housing colour:	pure white, similar to RAL 9010
Housing material:	PA plastic (30% GF reinforced)
Ambient temperature:	-30 to +70 °C
Permissible atmospheric humidity:	max. 95% rel. humidity, non-condensing
Max. measurement current (passive):	< 1 mA
Electrical connection:	screw-type terminals 0.14 mm ² - 2.5 mm ² only at safety extra-low voltage passive max. 30 V AC / 42 V DC
Mounting/attachment:	on pipe by means of cable tie-wrap
Tolerances:	PT100/PT1000
Protection rating:	IP65
Protection class:	III
Safety and EMC:	according to DIN EN 60730
Sensor characteristic curves:	the sensor characteristic curves can be found in the 'Miscellaneous' section

APPLICATION

The ALF contact temperature sensors are used for temperature measurement on pipes, tubes or heat carriers.

For better temperature transmission between the pipe and the contact sensor, the use of a heat conducting paste is recommended.

Please follow the EMC directives, avoid parallel routing with mains voltage-bearing wires, or use shielded wires.

SENSOR	TYPE	ITEM NO.	EURO/PG
PT 100	ALFP 100	G9050010	30.30/III
PT 1000	ALFP 1000	G9050020	30.30/III
'Sensor 0' (NTC 2K25)	ALF-0	G9050270	30.30/III
'Sensor 2' (NTC 47K)	ALF-2	G9050160	30.30/III
'Sensor 3' (NTC 8K)	ALF-3	G9050180	30.30/III
'Sensor 4' (NTC 10K)	ALF-4	G9050190	30.30/III
'Sensor 5' (NTC 50K)	ALF-5	G9050200	30.30/III
'Sensor 51' (KTY 81-121)	ALF-51	G9050210	30.30/III

ACCESSORIES	ITEM NO.	FEATURES	EURO/PG
WP-01	G9990180	heat conduction paste 2 ml	7.70/II

ILLUSTRATIONS

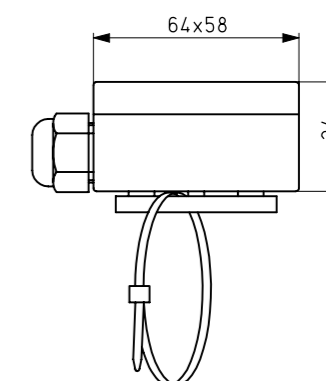
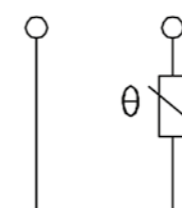

PENDULUM TEMPERATURE SENSOR PF



TECHNICAL DATA

Sensor material:	Al black, PVC wire
Sensor dimensions:	Ø 60 mm
Ambient temperature:	-30 to +80 °C
Permissible atmospheric humidity:	max. 95% rel. humidity, non-condensing
Max. measurement current:	< 1 mA
Electrical connection:	only at protective low voltage max. 30 VAC / 42 VDC
Extendable sensor wire:	depending on the cross-section of the Conductor and sensor type
Connecting cable:	2 x 0.5 mm ²
Mounting / attachment:	suspended
Tolerances:	PT100 / PT1000 DIN EN 60751 B NI1000 DIN EN 43760 B
Protection rating:	IP65
Protection class:	III
Safety and EMC:	according to DIN EN 60730
Sensor characteristic curves:	the sensor characteristic curves can be found in the 'Miscellaneous' section

APPLICATION

The pendulum temperature sensor PF serves to measure the temperatures in larger spaces. Owing to the spherical form, this sensor captures the temperature from all directions of the room, so that when correctly positioned in the room, a representative measurement result can be achieved.

Please follow the EMC directives, avoid parallel routing with mains voltage-bearing wires, or use shielded wires.

SENSOR	TYPE	ITEM NO.	FEATURES	EURO/PG
PT 100	PFP 100	G9130010	Wire length: 1 m	103.60/III
PT 1000	PFP 1000	G9130020	Wire length: 1 m	103.60/III
'Sensor 4' NTC 10 K	PFC 10	G9130070	Wire length: 1 m	103.60/III
'Sensor 2' NTC 47 K	PFC 47 / 6 (6 m)	G9130180	Wire length: 6 m	109.70/III

ILLUSTRATIONS

PF

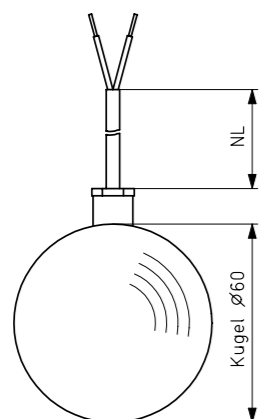

RADIATION TEMPERATURE SENSOR STF



TECHNICAL DATA

Design:	Berlin 2000
Housing colour:	pure white, similar to RAL 9010, ball black
Housing material:	ABS plastic
Ambient temperature:	-20 to +60 °C
Permissible atmospheric humidity:	max. 95% rel. humidity, non-condensing
Max. measurement current:	< 1 mA
Electrical connection:	screw-type terminals 0.14 mm ² up to 1.5 mm ² only at protective low voltage max. 30 VAC / 42 VDC
Extendable sensor wire:	depending on the cross-section of the conductor and the sensor unit type
Mounting / attachment:	surface / wall mounting (4-hole assembly on flush-mounted socket)
Protection rating:	IP30
Protection class:	III
Safety and EMC:	according to DIN EN 60730
Sensor characteristic curves:	the sensor characteristic curves can be found in the 'Miscellaneous' section

APPLICATION

The radiation temperature sensor is a dual sensor for the measurement of radiation and room heat. The radiation sensor is located in the black hemisphere; the room sensor is located in the plastic housing. Connection with screw-type terminals.

Please follow the EMC directives, avoid parallel routing with mains voltage-bearing wires, or use shielded wires.

SENSOR	TYPE	ITEM NO.	EURO/PG
'Sensor 0' 2x NTC 2 K 25	STF-0	SN080100	88.20/III
'Sensor 2' 2x NTC 47 K	STF-2	SN080200	88.20/III
'Sensor 4' 2x NTC 10 K	STF-4	SN080400	88.20/III
'Sensor 51' 2x KTY-81-121	STF-51	SN080500	88.20/III

ILLUSTRATIONS

STF

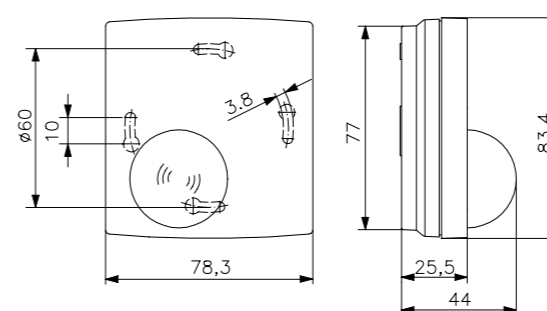

STF

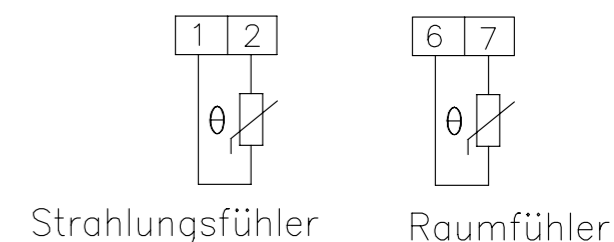

ASSEMBLY-TYPE DUCT SENSOR EKF WITH PASSIVE OUTPUT



TECHNICAL DATA

Housing colour:	pure white, similar to RAL 9010
Housing material:	PA plastic (30% GF reinforced)
Sensor tube material:	V2A (1.4301)
Ambient temperature:	-30 to +70 °C
Max. sensor temperature:	150 °C
Permissible atmospheric humidity:	max. 95% rel. humidity, non-condensing
Electrical connection:	screw-type terminals 0.14 mm ² up to 2.5 mm ² only at protective low voltage max. 30 VAC / 42 VDC
Tolerances:	PT100/PT1000 DIN EN 60751 B
Mounting/attachment:	in immersion sleeves (THMs, THV) for fluids or with mounting flange (MF) in air ducts
Protection rating:	IP65
Protection class:	III
Safety and EMC:	according to DIN EN 60730
Sensor characteristic curves:	the sensor characteristic curves can be found in the 'Miscellaneous' section
Immersion sleeves:	From the fitting length (EL), subtract 15 mm to determine the nominal length (NL) of the immersion sleeve, for example, EL = 65 mm corresponds to THV/50

APPLICATION

The assembly-type duct sensor EKF is used for measuring temperatures in liquids and gases in pipes, air ducts or tanks. A mounting flange (MF) is required for use in air ducts. If used in liquids, immersion sleeves made of brass with nickel plating (THMs) should be used. For aggressive media, immersion sleeves made of stainless steel V4A (THV) are recommended. Immersion sleeves or mounting flanges are not part of the delivery scope and must be **ordered separately** as accessories.

Accessories: mounting flange for installation in air ducts: MF matching immersion sleeves in brass: Immersion sleeves with brass plating can be found in the 'Miscellaneous' section matching immersion sleeves stainless steel (V4A): immersion sleeves made of stainless steel can be found in the 'Miscellaneous' section

Extendable sensor wire: depending on the cross-section of the conductor and the sensor unit type

Please follow the EMC directives, avoid parallel routing with mains voltage-bearing wires, or use shielded wires.

SENSOR	FITTING LENGTH 65 MM (FOR 50-MM IMMERSION SLEEVES)	FITTING LENGTH 115 MM (FOR 100-MM IMMERSION SLEEVES)	FITTING LENGTH 165 MM (FOR 150-MM IMMERSION SLEEVES)	PG
PT 100	EKFP 100/50 Item no.: G9140010; € 44.00	EKFP 100/100 Item no.: G9140140; € 44.60	EKFP 100/150 Item no.: G9140270; € 46.00	III
PT 1000	EKFP 1000/50 Item no.: G9140020; € 44.00	EKFP 1000/100 Item no.: G9140150; € 44.60	EKFP 1000/150 Item no.: G9140280; € 46.00	III

ACCESSORIES	ITEM NO.	FEATURES	EURO/PG
MF	G9990160	mounting flange for integrated duct sensor	8.20/III

ILLUSTRATIONS

assembly-type duct sensor

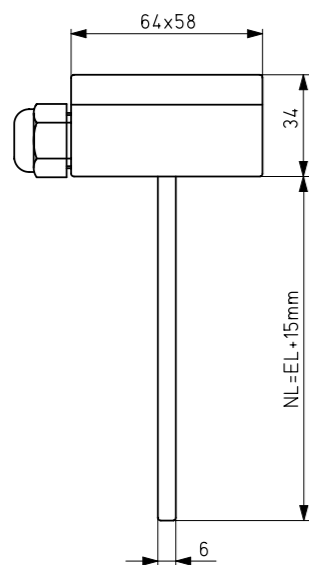

Mounting flange MF

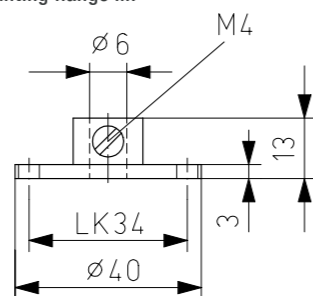

assembly-type duct sensor

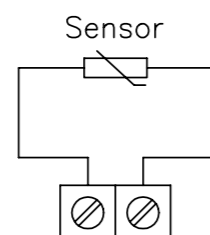

INDUSTRIAL ASSEMBLY-TYPE DUCT SENSOR IKF1 (FORM B) WITH PASSIVE OUTPUT



TECHNICAL DATA

Housing colour:	silver-grey
Housing material:	aluminium
Sensor tube material:	V2A (1.4301)
Ambient temperature:	-30 to +100 °C
Permissible atmospheric humidity:	max. 95% rel. humidity, non-condensing
Max. sensor temperature:	150 °C
Electrical connection:	screw-type terminals 0.14 mm ² up to 2.5 mm ² , only at protective low voltage max. 30 VAC / 42 VDC
Tolerances:	PT1000 DIN EN 60751 B
Mounting/attachment:	in immersion sleeves (THMs, THV) for fluids or with mounting flange (MF) in air ducts
Protection rating:	IP43
Protection class:	III
Safety and EMC:	according to DIN EN 60730
Sensor characteristic curves:	the sensor characteristic curves can be found in the 'Miscellaneous' section
Immersion sleeves:	from the fitting length (EL), subtract 15 mm to determine the nominal length (NL) of the immersion sleeve, for example, EL = 65 mm corresponds to THV/50
Accessories:	mounting flange for installation in air ducts: MF matching immersion sleeves in brass: immersion sleeves with brass plating can be found in the 'Miscellaneous' section matching immersion sleeves stainless steel (V4A): immersion sleeves made of stainless steel can be found in the 'Miscellaneous' section

APPLICATION

The industrial assembly-type duct sensor IKF1 is used for measuring temperatures of liquids and gases in pipes, air ducts or tanks in the mechanical and plant engineering sector. A mounting flange (MF) is required for use in air ducts. If used in liquids, immersion sleeves made of brass with nickel plating (THMs) should be used. For aggressive media, immersion sleeves made of stainless steel V4A (THV) are recommended. Immersion sleeves or mounting flanges are not part of the delivery scope and must be **ordered separately** as accessories.

Sensor wire extendable: depending on the cross-section of the conductor and the sensor unit type

Please follow the EMC directives, avoid parallel routing with mains voltage-bearing wires, or use shielded wires.

SENSOR	FITTING LENGTH (EL) 65 MM (FOR 50-MM IMMERSION SLEEVES)	FITTING LENGTH (EL) 115 MM (FOR 100-MM IMMERSION SLEEVES)	FITTING LENGTH (EL) 165 MM (FOR 150-MM IMMERSION SLEEVES)	PG
PT 1000	IKF1P 1000/50 Item no.: G9150020; € 75.40	IKF1P 1000/100 Item no.: G9150150; € 77.20	IKF1P 1000/150 Item no.: G9150280; € 78.70	III

ACCESSORIES	ITEM NO.	FEATURES	EURO/PG
MF	G9990160	mounting flange for integrated duct sensor	8.20/III

ILLUSTRATIONS

Industrial assembly-type duct sensor

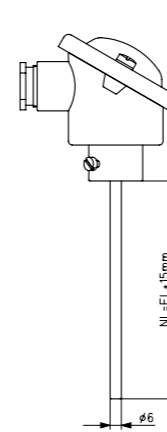

Mounting flange MF

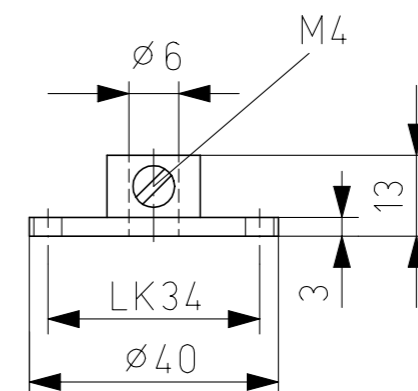

IKF

Sensor

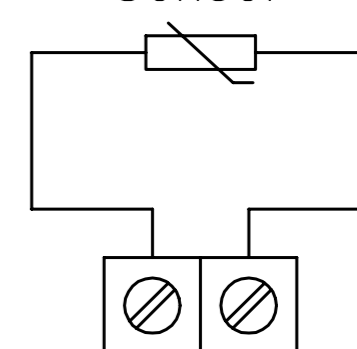



TRANSDUCER 'DIFFERENTIAL PRESSURE – AIR'



TECHNICAL DATA

Housing colour:	grey
Housing material:	plastic
Material of parts coming in contact with the medium:	Ni, PU, Al, Au, Pyrex glass, silicone, Kovar, Duraplast, Ultem Plasic
Operating voltage:	15–30 VDC, 15–30 VAC
Ambient temperature:	10 to 50 °C
Permissible atmospheric humidity:	max. 80% rel. humidity, non-condensing
max. pressure:	5 times the measurement range end value (relative pressure)
Electrical connection:	screw-type terminals up to 1.5 mm ²
Mounting / attachment:	wall mounting
Protection rating:	IP54
Protection class:	III
Safety and EMC:	according to DIN EN 60730
Sensor:	piezo-resistive pressure sensor
Pressure connection:	d x L: 6.6 x 10 mm (for flexible tubes d = 6 mm)
Cable gland:	M 12 x 1.5
Output signal:	continuous, adjustable 0–10 V, 0–20 mA, 4–20 mA
Accuracy:	Linearity: +/- 2% FS Influence of supply: <0.05% Influence of position: 0.1% at 3000 Pa, 0.3% at 1500 Pa, 0.9% at 500 Pa, 1.8% at 250 Pa Temperature drift: offset and range respectively +/- 0.12% FS/K Long-term stability: +/- 2% FS/year

APPLICATION

The microprocessor-controlled pressure transducers are suitable for detecting overpressure, underpressure or differential pressure of non-aggressive gases.

They are used in heating, ventilation or air conditioning applications as well as in clean room technology or for fine draft measurement.

The pressure measurement is performed using a piezo-resistive pressure sensor.

The types MDEKD replace the types DF.

Please follow the EMC directives, avoid parallel routing with mains voltage-bearing wires, or use shielded wires.

TYPE	ITEM NO.	MEASUREMENT RANGES	EURO/PG
MDEKD-940.000	G9270010	1000 Pa, 750 Pa; 500 Pa; 250 Pa relative pressure	182.90 / III
MDEKD-940.100	G9270020	10000 Pa; 7500 Pa; 5000 Pa; 2500 Pa relative pressure	182.90 / III

ACCESSORIES	ITEM NO.	FEATURES	EURO/PG
JZ-27	G9990450	cover with 3.5-digit LC display for MDEKD, easy assembly	85.30 / III
JZ-06/1	H5309229	Connection set with duct connections made of plastic, 2 x 90° angles, 2 extensions 90 mm, 4 self-tapping screws, 2 m tube Ø 6 mm outside for differential pressure switch JDW, JDL, pressure transducer	11.60 / II

ILLUSTRATIONS

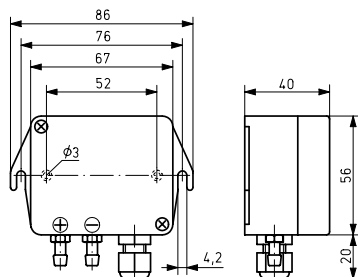

MDEKD with JZ-27





ACCESSORIES

CUSTOMISED AND HIGH-PERFORMANCE



ALRE ACCESSORIES.
MAKING SOPHISTICATED
TECHNOLOGY
**EVEN MORE
POWERFUL.**



**SAUNA-
CONTROLLERS** 226

ACCESSORIES 228

ANNEX 234

TECHNICAL ANNEX

Type comparison overview	234
Tips for heating installers and electricians	237
Ecodesign Directive and funding opportunities	238
Sensor characteristic curves	242
Technical terms	244

INDEX

Index by product designations	246
Index by type designations	248

GENERAL INFORMATION / CONTACT / ADDRESSES

Terms and conditions of sale and supply	250
General Notes	252
Contact information and contact persons	253

Upgrade your alre control technology with our wide selection of tailored accessories. Our products come with thorough technical guides, easy-to-follow assembly instructions, and practical usage tips for seamless integration. This catalogue offers a diverse range of accessories and replacement parts, along with expert insights to enhance your use of alre technology.

alre accessories: making good even better.

APPLICATION
EXAMPLES:

- + Controllers for dry and wet saunas
- + Process connections for liquid and gaseous media
- + Various accessories



SAUNATHERM VU / HYGROTHERM VU

SAUNA CONTROLLERS FOR DRY AND WET SAUNAS

**TECHNICAL DATA**

Colour:	cream white, similar to RAL 9001
Housing material:	ABS
Mains voltage:	400 VAC, 3/N 50 Hz
Equipment:	sensor rupture / short-circuit safeguarding, 'light' switch, 'ON / OFF' switch, 'light / fan / electronics' microfuse, 'ON / OFF' contact input
Trigger temperature of safety temperature limiter:	approx. 141 °C
Heating time limit:	6 h / 12 h / none
Pre-selection timer:	can be set to max. 12 h, 1-h intervals
Switching power, furnace:	max. 9 kW (max. 3 kW per phase)
Switching power, light:	max. 100 W, 230 VAC, 50 Hz
Switching power, fan:	max. 100 W, 230 VAC, 50 Hz
Switching element:	safety protection, relay 3-stage switching
Hysteresis:	approx. 1 K
Display type:	LED
Protection rating:	IP44
Protection class:	II, if properly mounted
Fuse:	T1, 25 A (5x20)
Scope of delivery:	control unit, sensor / STB, fastening screws
Mounting:	wall mounting
Ambient temperature:	-15 to +25 °C
Electrical connection:	screw-type terminals
Permissible atmospheric humidity:	max. 95% rel. humidity, non-condensing

APPLICATION

Sauna controllers for dry or dry / wet saunas.

Load expansion possible with LG 9 / 18 (18 kW) or LG 9 / 30 (30 kW).

TYPE/IMAGE	ITEM NO.	FEATURES	EURO/PG
------------	----------	----------	---------

Saunatherm VU	D4700653	Sauna controller for dry saunas (Finnish) Control range: 30 to 120 °C Switch: 'Fan On / Off' Indicators: 'HEATING', 'ON / OFF', 'pre-selection timer'	369.00 / III
---------------	----------	--	--------------



Hygrotherm VU	D4700736	Sauna controller for dry saunas (Finnish) or wet saunas Control range, dry sauna: 80 to 110 °C Control range, wet sauna: 40 to 60 °C / approx. 40–95% rel. humidity Switching power vaporiser: max. 3 kW Switch: 'Fan, 3-stage' Indicators: 'heating', 'ON / OFF', 'pre-selection timer' Water shortage detection Post-operation drying temperature adjustable: approx. 60 to 80 °C Post-operation drying limitation: approx. 3.5 h Fan post-operation time: approx. 15 minutes	551.20 / III
---------------	----------	--	--------------



ACCESSORIES FOR SAUNATHERM VU / HYGROTHERM VU

SAUNA CONTROLLERS FOR DRY AND WET SAUNAS

TYPE/IMAGE	ITEM NO.	FEATURES	EURO/PG
------------	----------	----------	---------

LG 9 / 18	D4710450	Power switching unit 9 kW (max. 3 kW per phase) With this unit, all control units can be enhanced from 9 kW to 18 kW switching power (9 kW via control unit + 9 kW via load switch = 18 kW total power).	213.60 / III
-----------	----------	---	--------------



LG 9 / 30	H4690008	Power switching unit 21 kW (max. 7 kW per phase) With this unit, all control units can be enhanced from 9 kW to 30 kW switching power (9 kW via control unit + 21 kW via load switch = 30 kW total power).	813.80 / III
-----------	----------	---	--------------

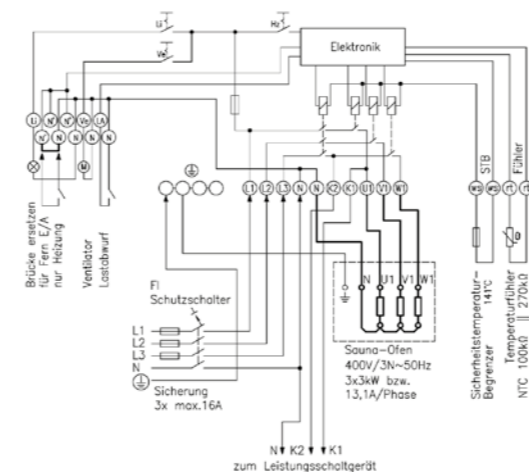
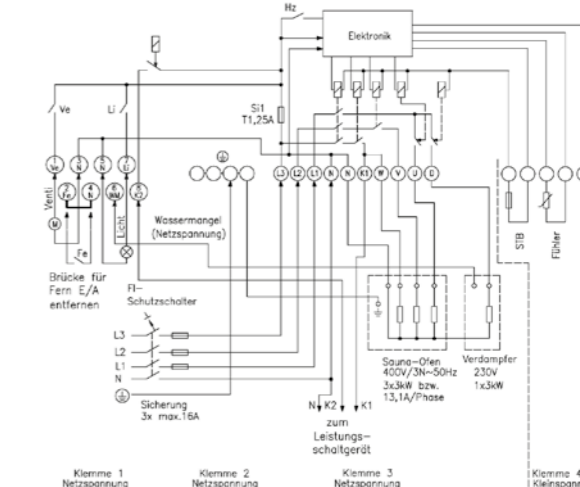
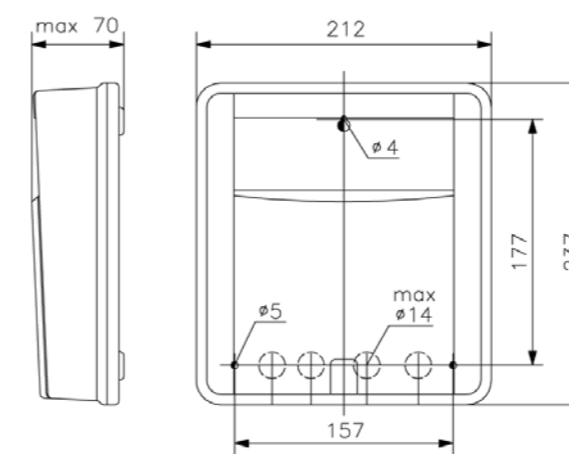
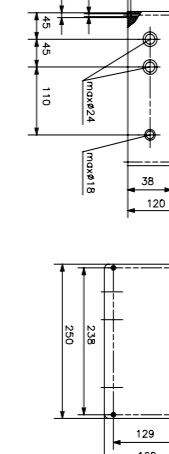
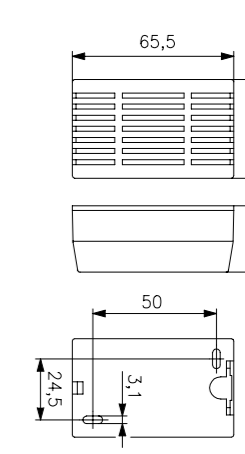

Sensor / STB	D4700662	Spare sensor / STB for Saunatherm VU and Hygrotherm VU	65.90 / III
--------------	----------	--	-------------

**ILLUSTRATIONS****Saunatherm VU****Hygrotherm VU****Sauna controllers, LG 9 / 18****LG 9 / 30****Sensor / STB**



IMMERSION SLEEVES / PROTECTION COILS FOR RTKSA AND FOR SLEEVE AND CABLE SENSORS

FOR INDUSTRIAL APPLICATIONS AND HEATING TECHNOLOGY

ILLUSTRATIONS

THK / NTHK

SW-200 / SW-200-12

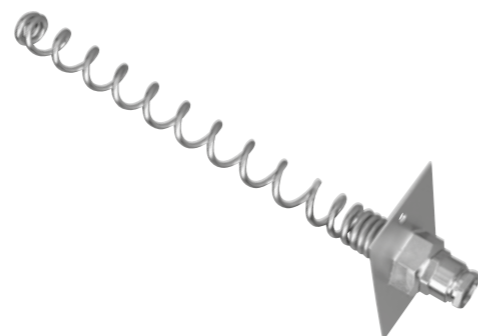
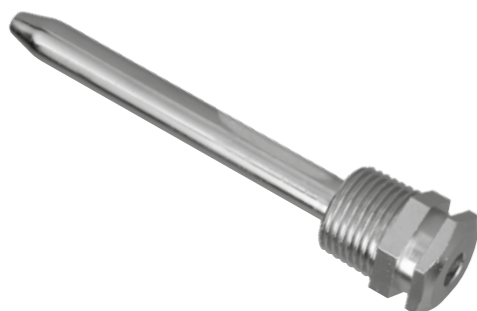

IMMERSION SLEEVES FOR RTKSA

TYPE	ITEM NO.	LENGTH OF L	DIAMETER I X A*	MATERIAL	MAX. PRES-SURE (P/BAR)	EURO/PG
THK-2-100	KA969901	100 mm	7.5 x 10 mm	nickel-plated brass	20	22.50 / II
THK-2-120	KA969902	120 mm	7.5 x 10 mm	nickel-plated brass	20	25.70 / II
THK-2-200	KA969903	200 mm	7.5 x 10 mm	nickel-plated brass	20	26.40 / II
THK-2-280	KA969904	280 mm	7.5 x 10 mm	nickel-plated brass	20	32.10 / II
THK-2-600	KA969905	600 mm	7.5 x 10 mm	nickel-plated brass	20	51.10 / II
NTHK-2-100	KA969906	100 mm	7.5 x 10 mm	V4 A (1.4571)	40	61.20 / II
NTHK-2-120	KA969907	120 mm	7.5 x 10 mm	V4 A (1.4571)	40	62.10 / II
NTHK-2-200	KA969908	200 mm	7.5 x 10 mm	V4 A (1.4571)	40	63.30 / II
NTHK-2-280	KA969909	280 mm	7.5 x 10 mm	V4 A (1.4571)	40	64.80 / II
THK-2-100 x 17	KA979901	100 mm	14.8 x 17 mm	nickel-plated brass	20	32.60 / II
THK-2-200 x 17	KA979902	200 mm	14.8 x 17 mm	nickel-plated brass	20	43.80 / II
NTHK-2-100 x 17	KA979903	100 mm	14.8 x 17 mm	V4 A (1.4571)	40	63.70 / II
NTHK-2-200 x 17	KA979904	200 mm	14.8 x 17 mm	V4 A (1.4571)	40	66.00 / II

PROTECTION COIL FOR RTKSA

TYPE	ITEM NO.	LENGTH OF L	DIAMETER I X A*	MATERIAL	EURO/PG
SWK-2-100	KA989901	100 mm	10.5 x 17 mm	steel, nickel-plated	20.80 / II
SWK-2-120	KA989902	120 mm	10.5 x 17 mm	steel, nickel-plated	25.70 / II
SWK-2-200	KA989903	200 mm	10.5 x 17 mm	steel, nickel-plated	26.40 / II
SWK-2-280	KA989904	280 mm	10.5 x 17 mm	steel, nickel-plated	32.10 / II



IMMERSION SLEEVES / PROTECTION COILS FOR RTKSA AND FOR SLEEVE AND CABLE SENSORS

FOR INDUSTRIAL APPLICATIONS AND HEATING TECHNOLOGY

PROTECTION COIL FOR CAPILLARY FASTENING IN THE AIR DUCT (JET / JMT / JTF) AND ALL SLEEVE SENSORS HF AND CABLE SENSORS

TYPE	ITEM NO.	LENGTH OF L	LINE INSERTION	DIAMETER I X A*	MATERIAL	EURO/PG
SW-200	C1809219	200 mm	7.8 mm	11 x 17 mm	steel, nickel-plated	35.60 / II
SW-200-12	C1809220	200 mm	11.8 mm	11 x 17 mm	steel, nickel-plated	34.40 / II

* I = minimum inner diameter
A = nominal outer diameter

ILLUSTRATIONS

THK / NTHK

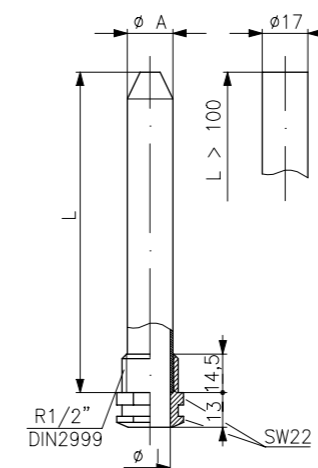

SWK

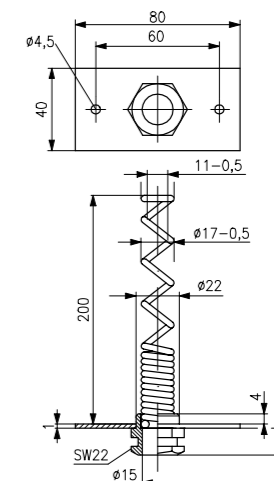

SW-200

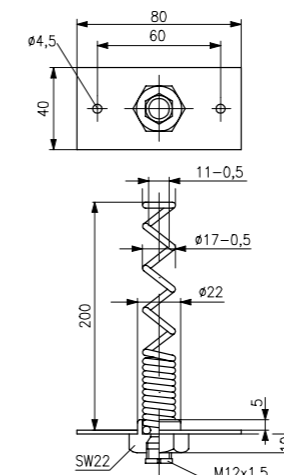

SW-200-12

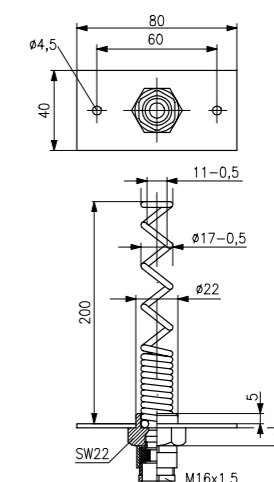



IMMERSION SLEEVES FOR CAPILLARY / FROST PROTECTION THERMOSTATS / HF / SCREED MOUNTING

FOR INDUSTRIAL APPLICATIONS AND HEATING TECHNOLOGY

ILLUSTRATIONS

TH/NTH



THF



FOR SENSORS HF Ø 7.7 MM, CAPILLARY AND FROST PROTECTION THERMOSTATS JET / JMT / WR 81 AND JTF (FOR JTF, ONLY TYPE TH / NTH-140)

TYPE	ITEM NO.	LENGTH OF L	DIAMETER I X A**	MATERIAL	MAX. PRESSURE (P/BAR)	EURO/PG
TH-55	C1809296	55 mm	8 x 10 mm	nickel-plated brass	20	23.70 / II
TH-100	C1809310	100 mm	8 x 10 mm	nickel-plated brass	20	26.00 / II
TH-140*	C1809409	140 mm	10 x 12 mm	nickel-plated brass	20	30.00 / II
TH-200	C1809438	200 mm	8 x 10 mm	nickel-plated brass	20	30.90 / II
TH-280	C1809440	280 mm	8 x 10 mm	nickel-plated brass	20	37.10 / II
NTH-55	C1809284	55 mm	8 x 10 mm	V4 A (1.4571)	40	59.40 / II
NTH-100	C1809308	100 mm	8 x 10 mm	V4 A (1.4571)	40	61.20 / II
NTH-140*	C1809435	140 mm	10 x 12 mm	V4 A (1.4571)	40	63.30 / II
NTH-200	C1809439	200 mm	8 x 10 mm	V4 A (1.4571)	40	64.10 / II
NTH-280	C1809441	280 mm	8 x 10 mm	V4 A (1.4571)	40	64.80 / II

* Suitable for all types with an X in the designation, for example JET-1 ... X or JMT 206 X

** I = minimum inner diameter
A = nominal outer diameter

CU PROTECTIVE SLEEVE FOR SLEEVE SENSOR HF / CABLE SENSOR KF FOR SCREED MOUNTING

TYPE	ITEM NO.	EURO/PG
THF	C1809515	45.00 / II

ILLUSTRATIONS

TH/NTH

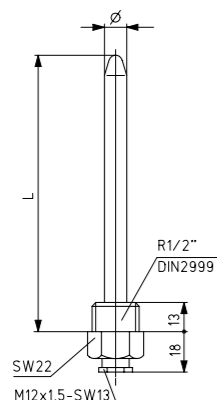

THF

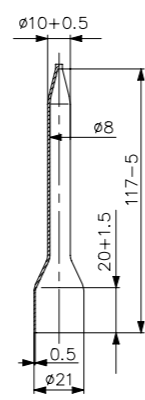

IMMERSION SLEEVES / MOUNTING FLANGE FOR HF, KF, EKF AND IKF FOR SLEEVE SENSORS / CABLE SENSORS Ø 6 MM PVC AND SILICONE, ASSEMBLY-TYPE AND INDUSTRIAL CABLE SENSORS

FOR SENSOR TECHNOLOGY

ILLUSTRATIONS

THMs

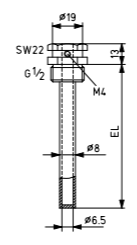

THV

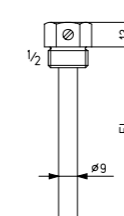

MF

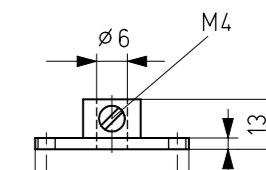

IMMERSION SLEEVES, NICKEL-PLATED, WITH RECESS

TYPE	ITEM NO.	FITTING LENGTH EL	DIAMETER I X A*	MAX. PRESSURE (P/BAR)	EURO/PG
THMs / 50	G9990010	50 mm	6.5 x 8 mm	20	15.60 / II
THMs / 100	G9990020	100 mm	6.5 x 8 mm	20	16.20 / II
THMs / 150	G9990030	150 mm	6.5 x 8 mm	20	17.40 / II
THMs / 200	G9990040	200 mm	6.5 x 8 mm	20	17.90 / II
THMs / 250	G9990050	250 mm	6.5 x 8 mm	20	18.90 / II
THMs / 300	G9990370	300 mm	6.5 x 8 mm	20	19.60 / II

IMMERSION SLEEVES, STAINLESS STEEL V4 A 1.4571

TYPE	ITEM NO.	FITTING LENGTH EL	DIAMETER I X A*	MAX. PRESSURE (P/BAR)	EURO/PG
THV / 50	G9990060	50 mm	6.3 x 9 mm	40	34.30 / II
THV / 100	G9990070	100 mm	6.3 x 9 mm	40	35.70 / II
THV / 150	G9990080	150 mm	6.3 x 9 mm	40	37.60 / II
THV / 200	G9990090	200 mm	6.3 x 9 mm	40	39.00 / II
THV / 250	G9990100	250 mm	6.3 x 9 mm	40	40.50 / II
THV / 300	G9990200	300 mm	6.3 x 9 mm	40	41.70 / II
THV / 400	G9990210	400 mm	6.3 x 9 mm	40	45.10 / II
THV / 450	G9990470	450 mm	6.3 x 9 mm	40	46.10 / II
THV / 500	G9990220	500 mm	6.3 x 9 mm	40	48.30 / II
THV / 600	G9990400	600 mm	6.3 x 9 mm	40	51.30 / II

MOUNTING FLANGE, ALUMINIUM

TYPE	ITEM NO.	FITTING LENGTH EL	DIAMETER I X A*	MAX. PRESSURE (P/BAR)	EURO/PG
MF	G9990160		6 x 40 mm		8.20 / III

* I = minimum inner diameter
A = nominal outer diameter

**ACCESSORIES**FOR HEATING TECHNOLOGY / AIR CONDITIONING TECHNOLOGY /
PLANT ENGINEERING AND SENSOR TECHNOLOGY

TYPE	ITEM NO.	DESCRIPTION	EURO/PG
ATRS-1	C1809518	Temperature determination set for ATR 83.0...	3.10/II
ET-01	MA990000	Adjusting knob for B1000 series devices, scale: degrees Celsius, pure white glossy	3.70/I
ET-02	MA990001	Adjusting knob for B1000 series devices, multi-digit display 1 to 6, pure white glossy	3.70/I
ET-10	MA990002	Adjusting knob for B2000 series devices, multi-digit display 1 to 6, pure white glossy	3.50/I
FS-HI	H530975	Sensor protection (protective wire braiding) for duct hygrostat HI	18.50/II
FS2-HI	H531011	PTFE filter fine protection for duct hygrostat HI	79.20/II
JZ-04	E6160133	Capillary tube leadthrough for air ducts with 30-cm protective hose (JTF frost protection thermostats, JMT capillary controllers, WR, JET)	15.30/II
JZ-05 / 6 K	C1809536	1 set of mounting brackets (6 pieces) for frost protection thermostat JTF, made of plastic (max. 145 °C)	14.50/II
JZ-05 / 6 M	C1809474	1 set of mounting brackets (6 pieces) for frost protection thermostat JTF, made of metal	15.40/II
JZ-05 / 1 M	C1809462	Single mounting bracket for frost protection thermostat JTF, made of metal	3.50/II
JZ-06 / 1	H5309229	Connection set with duct connections made of plastic, 2 x 90° angles, 2 extensions 90 mm, 4 self-tapping screws, 2-m tube Ø 6 mm outside for JDW differential pressure switch, JDL, DF pressure transducer	11.60/II
JZ-07	E6160145	Mounting bracket for frost protection thermostats JTF	6.90/II
JZ-08	E6150031	Spare vane for wind indication relay JSL	23.10/II
JZ-09	E6140170	Spare paddles (4 pieces), from 1" to 8" for flow monitor JSF	23.10/II
JZ-10	H5309237	Mounting bracket for JDL 109/-113 and JDW-3/-5/-10 with 6 screws	6.20/II
JZ-13	ZA990001	Standard rail with drilled holes for fastening control cabinet controllers (length 40 mm)	6.00/II
JZ-17	MN990001	Adapter plate for Berlin 3000 housing (hard-wired)	8.20/II
JZ-18	MN990002	Adapter snap-on plate (controller is detachable) for Berlin 3000 housing (wireless)	8.20/II
JZ-19	MN990003	Fully prewired plug-in socket (as for RTBSB-001.411), can be fitted with room thermostats RTBSB-001.086 or RTBSB-001.096	44.00/I
JZ-20-1	E6130144	Wall holder including fastening material for duct hygrostat (HI)	24.10/II
JZ-21	MN990006	Adapter frame for mounting devices of the Berlin 1000 series in flush-mounted sockets up to 80 x 80 mm	5.60/I
JZ-24	BN990002	Magnetic fastening set for simple and safe fastening of Multi-channel receiver or wiring strips VOORL	25.80/II
JZ-25	BN990003	External antenna for reception enhancement under difficult reception conditions of the multi-channel receiver, antenna cable (JZ-26) is not a part of the delivery scope	72.70/II
JZ-26	BN990004	Antenna cable 1 m for connecting the external antenna JZ-25 with multi-channel receivers	47.90/II
JZ-27	G9990450	LC-display 3½ digit, for MDEKD	85.30/III
JZ-28	H531012	IP65 cover set, consisting of a cover with pressure compensation element, O-ring and 3 screws, suitable for retrofitting of the types JDL-111, JDL-112, JDL-114, JDL-115 and JDL-116	64.00/II
JZ-29	KA999901	Mounting set RTKSA for THK/NTHK/SWK single thermostat	4.50/II
JZ-30	KA999902	Mounting set RTKSA for THK/NTHK/SWK double thermostat	7.10/II
JZ-31	KA999903	Mounting set RTKSA for pipe mounting as contact thermostat	5.50/II
JZ-32	BN990005	Magnet attachment set for terminal strips VOOPL-216.176/VOOPL-318.178 and radio multi-channel receiver HTFRL-214.240/HTFRL-316.225	19.30/II
JZ-33	KA999904	RTKSA seal set, protection rating: IP54	18.50/II
JZ-090.900	VV000025	alre frame 'Berlin' for all flush-mounted controllers with 50 x 50 cover, pure white, glossy, similar to RAL 9010 Fastening of the VOOPL terminal strip on a metallic substrate (for example, heating manifold)	4.80/I
JZ-090.910	VV000010	alre frame 'Berlin' for all flush-mounted controllers with 50 x 50 cover, pearl white, glossy, similar to RAL 1013	4.80/I
JZ-090.100	VV000048	alre frame 'Berlin' for all flush-mounted controllers with 55 x 55 cover, pure white, glossy, similar to RAL 9010. Fastening of the VOOPL terminal strip on a metallic substrate (for example, heating manifold)	4.80/I
S protection 01	G9990170	Ball impact guard, sun and rain protection; 150 x 90 x 47 mm; stainless steel V4A 1.4571	40.00/III
WP-01	G9990180	heat conduction paste 2 ml	7.70/II

ILLUSTRATIONS

S protection 01

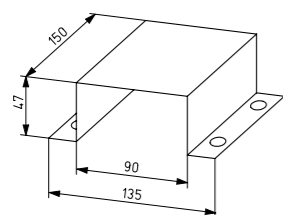

alre frame 'Berlin'

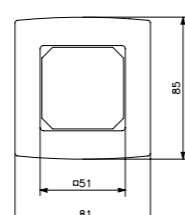
**ACCESSORIES**FOR HEATING TECHNOLOGY / AIR CONDITIONING TECHNOLOGY /
PLANT ENGINEERING AND SENSOR TECHNOLOGY

ET-01	ET-02	ET-10	FS-HI



TYPE COMPARISON OVERVIEW

ROOM TEMPERATURE CONTROLLER MECHANICAL OLD (FTR) AND NEW (RTBSU):

ITEM NO. OLD	OLD TYPE	ITEM NO. NEW	NEW TYPE	REMARKS
UA010017	FTR 101.000#00	UA090000	RTBSU-401.000#00	
UN010009	FTR 101.000#21	UA090014	RTBSU-401.000#21	
UA010134	FTR 101.002#00	UA090001	RTBSU-401.002#00	
UA010222	FTR 101.010#00	UA090002	RTBSU-401.010#00	
UA012404	FTR 101.034#07	UA090004	RTBSU-401.034#00	+ JZ-016.000
UA012405	FTR 101.034#55	UA090004	RTBSU-401.034#00	+ JZ-016.100
UA010702	FTR 101.052#21	UA090015	RTBSU-401.052#21	
UA010811	FTR 101.062#00	UA090003	RTBSU-401.062#00	
UA011000	FTR 101.063#00	UA090006	RTBSU-401.063#00	
UA010910	FTR 101.065#00	UA090007	RTBSU-401.065#00	
UA010415	FTR 101.075#00	UA090008	RTBSU-401.075#00	
UA010615	FTR 101.086#00	UA090009	RTBSU-401.086#00	
UN010607	FTR 101.086#21	UA090016	RTBSU-401.086#21	
UA012008	FTR 101.202#00	UA090010	RTBSU-401.202#00	
UN102009	FTR 101.202#21	UA090010	RTBSU-401.202#00	+ JZ-001.000 + JZ-090.900
UA012301	FTR 101.210#00	UA090011	RTBSU-401.210#00	
UA012500	FTR 101.262#00	UA090012	RTBSU-401.262#00	
UA012501	FTR 101.262#21	UA090012	RTBSU-401.262#00	+ JZ-035.000 + JZ-090.900
UA012600	FTR 101.265#00	UA090017	RTBSU-401.265#00	
UA013000	FTR 101.902#07	UA090013	RTBSU-401.902#07	

SPARE PARTS COVER SETS FTR ON REQUEST.

TERMINAL STRIP FOR HEATING MANIFOLD:

ITEM NO. OLD	OLD TYPE	REMARKS	ITEM NO. NEW	NEW TYPE	REMARKS
DA480500	VOOPL-215.000	5-channel, IP20	DA480510	VOOPL-216.176	6-channel, IP20
DA480200	VOOPD-215.000	5-channel, IP65	DA480510	VOOPL-216.176	6-channel, IP20
DA480400	VOOPL-318.000	8-channel, IP20	DA480520	VOOPL-318.178	8-channel, IP20
DA480300	VOOPD-318.000	8-channel, IP65	DA480520	VOOPL-318.178	8-channel, IP20

PLANT ROOM THERMOSTAT OLD (JET-4X/ JET-3X) AND NEW (RTKSA):

OLD ALRE TYPES	CONTROL RANGE	HYSTERESIS	NEW ALRE TYPES	CONTROL RANGE	HYSTERESIS
JET-40	0 to +35 °C	1 K	RTKSA-100.010	-10 to +40 °C	1.3 K
JET-40F	0 to +35 °C	1 K	RTKSA-101.010	-10 to +40 °C	1.3 K
JET-41	0 to +70 °C	2 K	RTKSA-100.110	0 to +50 °C	1.3 K
JET-41F	0 to +70 °C	2 K	RTKSA-101.110	0 to +50 °C	1.3 K
JET-30	10 to 45 °C (external) TR 0 to 35 °C (internal) TW	approx. 1 K	RTKSA-114.110	0 to +50 °C (internal) TW 0 to +50 °C (internal) TW	1.3 K
JET-31	10 to +45 °C (internal) TW 0 to +35 °C (internal) TW	approx. 1 K			

TR = temperature controller, TW = temperature monitor



TYPE COMPARISON OVERVIEW

BOILER / VENTILATION THERMOSTATS

(OLD) (KR/LR) AND UNIVERSAL CAPILLARY THERMOSTAT (NEW) (RTKSA):

OLD ALRE TYPES	CONTROL RANGE	HYSTERESIS	NEW ALRE TYPES	CONTROL RANGE	HYSTERESIS	ACCESSORIES
KR 80.312	fixed at 100 °C	-20 K	RTKSA-003.310	20 to 150 °C	-10 K	THK-2-100 + JZ-29
LR 80.312	fixed at 100 °C	-20 K				SWK-2-100 + JZ-29
KR 80.318	fixed at 100 °C	-20 K				THK-2-200 + JZ-29
LR 80.318	fixed at 100 °C	-20 K				SWK-2-200 + JZ-29
KR 80.309	fixed at 75 °C	-20 K				THK-2-100 + JZ-29
LR 80.309	fixed at 75 °C	-20 K				SWK-2-100 + JZ-29
KR 80.310	fixed at 75 °C	-20 K				THK-2-200 + JZ-29
LR 80.310	fixed at 75 °C	-20 K				SWK-2-200 + JZ-29
KR 80.206	30 to 65 °C	-8 K	RTKSA-002.410	30 to 110 °C	-10 K	THK-2-100 + JZ-29
KR 80.206 IP54	30 to 65 °C	-8 K				THK-2-100 + JZ-29
KR 80.207	60 to 95 °C	-8 K				THK-2-100 + JZ-29
LR 80.207	60 to 95 °C	-8 K				SWK-2-100 + JZ-29
KR 80.208	85 to 120 °C	-8 K	RTKSA-002.310	20 to 150 °C	-10 K	THK-2-100 + JZ-29
KR 80.202	95 to 130 °C	-8 K				THK-2-100 + JZ-29
KR 80.203	95 to 130 °C	-8 K				THK-2-200 + JZ-29
LR 80.203	95 to 130 °C	-8 K				SWK-2-200 + JZ-29
KR 80.203 IP54	95 to 130 °C	-8 K				THK-2-200 + JZ-29
WR 81.029-1	0 to 35 °C	0.5-1 K				-
KR 80.003-1	0 to 35 °C	1 K	RTKSA-000.100	0 to 50 °C	1.3 K	THK-2-200 + JZ-29
LR 80.003-1	0 to 35 °C	1 K				SWK-2-200
WR 81.009-2	0 to 70 °C	1-2 K	RTKSA-000.200	0 to 120 °C	3 K	-
KR 80.035-2	0 to 70 °C	2 K				THK-2-100 + JZ-29
KR 80.027-5	0 to 70 °C	5 K				THK-2-100 + JZ-29
LR 80.027-5	0 to 70 °C	5 K				SWK-2-100 + JZ-29
LR 80.035-2	0 to 70 °C	2 K				SWK-2-100 + JZ-29
KR 80.028-2	0 to 70 °C	2 K				THK-2-200 + JZ-29
LR 80.028-2	0 to 70 °C	2 K				SWK-2-200 + JZ-29
KR 80.029-2	0 to 70 °C	2 K				THK-2-280 + JZ-29
KR 80.029-2 V4A	0 to 70 °C	3 K				NTHK-2-280 + JZ-29
LR 80.029-2	0 to 70 °C	2 K				SWK-2-280 + JZ-29
KR 80.011-1 V4A	10 to 45 °C	1 K				NTHK-2-120 + JZ-29
KR 80.009-1 V4A	10 to 45 °C	1 K				NTHK-2-200 + JZ-29
KR 80.000-5	35 to 95 °C	5 K				THK-2-100 + JZ-29
KR 80.001-5	35 to 95 °C	5 K				THK-2-200 + JZ-29
KR 80.001-5 V4A	35 to 95 °C	5 K	NTHK-2-200 + JZ-29			
KR 80.008-8	40 to 110 °C	8 K	THK-2-100 + JZ-29			



TYPE COMPARISON OVERVIEW

BOILER / VENTILATION THERMOSTATS (OLD) (KR / LR) AND UNIVERSAL CAPILLARY THERMOSTAT (NEW) (RTKSA):

OLD ALRE TYPES	CONTROL RANGE	HYSTERESIS	NEW ALRE TYPES	CONTROL RANGE	HYSTERESIS	ACCESSORIES
KR 80.006-8	50 to 130 °C	8 K	RTKSA-000.300	20 to 150 °C	9.1 K	THK-2-100 + JZ-29
WR 81.101-1	0 to 35 °C	0.5–1 K	RTKSA-001.100	0 to 50 °C	1.3 K	-
WR 81.129-1	0 to 35 °C	0.5–1 K				-
KR 80.108-1	0 to 35 °C	1 K				-
LR 80.108-1	0 to 35 °C	1 K				-
KR 80.109-1	0 to 35 °C	1 K				THK-2-200 + JZ-29
LR 80.109-1	0 to 35 °C	1 K				SWK-2-200 + JZ-29
WR 81.115-5	0 to 70 °C	4 K	RTKSA-001.200	0 to 120 °C	3 K	JZ-31
WR 81.109-2	0 to 70 °C	1–2 K				-
KR 80.116-2	0 to 70 °C	2 K				THK-2-100 + JZ-29
LR 80.116-2	0 to 70 °C	2 K				SWK-2-100 + JZ-29
KR 80.111-3	0 to 80 °C	1 K				THK-2-100 + JZ-29
KR 80.120-1	10 to 45 °C	1 K				THK-2-200 + JZ-29
LR 80.120-1	10 to 45 °C	1 K				SWK-2-200 + JZ-29
KR 80.100-5	35 to 95 °C	5 K				RTKSA-001.301
KR 80.100-5 IP54	35 to 95 °C	5 K	NTHK-2-100 + JZ-29			
KR 80.101-5	35 to 95 °C	5 K	THK-2-200 + JZ-29			
LR 80.101-5	35 to 95 °C	5 K	SWK-2-200 + JZ-29			
KR 80.124-5	35 to 95 °C	5 K	THK-2-280 + JZ-29			
KR 80.112-5	35 to 95 °C	8 K	THK-2-600 + JZ-29			
KR 80.102-8	40 to 110 °C	8 K	RTKSA-001.300	20 to 150 °C	9.1 K	THK-2-100 + JZ-29
KR 80.103-8	40 to 110 °C	8 K				THK-2-200 + JZ-29
WR 81.117-5	50 to 130 °C	4 K				JZ-31
KR 80.106-8	50 to 130 °C	8 K				THK-2-100 + JZ-29

FROST PROTECTION THERMOSTAT OLD (JTF-1XX) AND NEW (RTKSA):

OLD ALRE TYPES	CAPILLARY LENGTH	GENERAL FEATURES	NEW ALRE TYPES	CAPILLARY LENGTH	GENERAL FEATURES
JTF-101	6 m	Protection rating: IP54 Hysteresis: approx. 1 K Control range: –8 to +8 °C Tmax sensor: 150 °C	RTKSA-204.200	6 m	Protection rating: IP40 Hysteresis: approx. 1.5 K Control range: –10 to +15 °C Tmax sensor: 120 °C
JTF-103	1.8 m		RTKSA-204.000	1.8 m	
JTF-105	3 m		RTKSA-204.100	3 m	
JTF-112	12 m		RTKSA-204.300	12 m	

TIPS FOR HEATING INSTALLERS AND ELECTRICIANS

BERLIN 1000 / 2000 / 3000 – **BIMETAL**

PROBLEM	CAUSE
Large temperature variation present in the room (approx. 5–8 K).	<ol style="list-style-type: none"> 1.) The neutral conductor N is not connected to terminal 4 of the controller. 2.) The neutral conductor N is connected to terminal 4 of the controller, but not in the distribution system (distribution box, fuse box).
The setting knob (setpoint transmitter) must be set higher than the desired room temperature.	<ol style="list-style-type: none"> 1.) Incoming and outgoing (switched) phase have been interchanged. As a result, the feedback resistor continuously carries a voltage and acts like a temperature reducer in the room. Moreover, the temperature variation is very high (approx. 5–8 K) 2.) The heating output is dimensioned too low for the room. As a result of this, the power-on time of the controller is too long; the feedback resistor is thus switched on for too long and acts as a temperature reducer in the room. 3.) External heat sources are influencing the controller (for example, the sun, TV, lamp etc.). These external heat sources cause the controller to register a higher-than-actual temperature and, as a result, the room is not heated sufficiently.
The setting knob (setpoint transmitter) must be set lower than the desired room temperature.	<ol style="list-style-type: none"> 1.) The controller has been installed, for example, behind a curtain or on an outer wall or next to a door. The controller registers a lower-than-actual temperature and, as a result, the room is overheated.
The room does not become warm.	<ol style="list-style-type: none"> 1.) Faulty actuator element, actuator element does not open the valve. 2.) There may be coarse construction site dirt in the controller. This dirt is preventing the contact from closing. 3.) The controllers of two rooms have been connected in series. These rooms only become warm when both controller contacts are closed.
TOPIC	NOTE
Reaction times – underfloor heating	<ol style="list-style-type: none"> 1.) Particularly with floor heating, it is important to remember that there are very long reaction times. Therefore, the room heats up very slowly and also cools slowly (incident sunlight, for example, results in overheating). So do not expect that a cold room will reach the desired room temperature within a short time after having set the adjusting knob to a high value.
Room temperature in well-insulated rooms	<ol style="list-style-type: none"> 2.) Also, with well insulated rooms, remember that the room temperature drops very slowly. As a result, it can happen that at night, despite 'Reduced operation' (for example, 4 K lower), the room temperature drops only a little and the heating therefore does not get activated for a prolonged time.
Installation instructions – bimetal controllers	<ol style="list-style-type: none"> 3.) Very often, the function of bimetal controllers is impaired or rendered completely useless by construction site dirt that has penetrated into them. Therefore, the controllers should be installed only after any required spatula, painting or wallpapering work. Avoid drilling dust without fail.

PLANT ENGINEERING

TOPIC	NOTE
Connecting industrial thermostats and controllers to PLC or DDC	For connecting industrial thermostats and controllers to programmable logic controllers (PLC) or direct digital controls (DDC), the use of normal commercial coupling relays with 230 V~ coil voltage and gold-plated switching contacts is recommended.



ECODESIGN DIRECTIVE

The Ecodesign Directive (EU 2015/1188) sets forth essential regulations for the marketing and implementation of household local space heaters. This directive, effective from August 10, 2015, with a transitional phase until January 1, 2018, aims to foster environmentally friendly design and labeling of local space heaters, ultimately leading to reduced energy consumption.









At alre, we fully support this initiative and the push towards energy-saving control technology. For nearly five decades, our focus has been on the development and production of innovative products that are optimized for energy efficiency. This commitment aligns perfectly with the goals of the Ecodesign Directive, as we continue to contribute to a more sustainable future.

The Directive distinguishes between different types of heating, electric local space heaters and local space heaters for gaseous or liquid fuels. The electric local space heaters are additionally subdivided into:

- + portable local space heaters,
- + fixed local space heaters,
- + storage local space heaters,
- + underfloor local space heaters and
- + Radiant local space heaters.

Central space heaters that distribute heat to different rooms via a liquid medium are not affected by this regulation.

The following table lists the products that comply with the Directive for use in portable local space heaters, fixed local space heaters and underfloor local space heaters. If you have any questions about suitable products for other types of heating, please do not hesitate to contact us.

PRODUCTS / PRODUCT GROUPS	ELECTRIC LOCAL SPACE HEATERS		
	PORTABLE	FIXED	UNDER-FLOOR
HTRRUu 210.021 see 'Heating technology' section 	x	x	x
HTRRBu 110.1xx / 21 see 'Heating technology' section 	x	x	x
Wireless system without weekly programme Actuators: HTRFB, HTFRE, HTFRU Sensors: FTRFB see 'Wireless systems' section 	x		
Wireless system with weekly programme* Actuators: HTRFB, HTFRE, HTFRU Sensors: FTRFB, FTRFBu, FTRFUD see 'Wireless systems' section 	x	x	x
RTBSU-401.xxx RTBSB-001.xxx RTBSB-001.4xx see 'Heating technology' section 	x		
RTBSU-401.xxx or RTBSB-001.xxx (variants with clock input) in conjunction with clock thermostat** see 'Heating technology' section 	x	x	x
RTERU-010.715 HTRRB-01x.xxx see 'Heating technology' section 	x		
RTERU-010.715 or HTRRB-01x.xxx in conjunction with clock thermostat** see 'Heating technology' section 	x	x	x

* Sensors with clock required in each room or master-slave control with central clock programme (transfer of central sensor functions with clock).

** Transfer of clock thermostat functions via clock output to the corresponding clock input of other thermostats.

FUNDING OPPORTUNITIES WITH THE BAFA SUBSIDY PROGRAMME

HEAT INTELLIGENTLY – SECURE A **20 PER CENT SUBSIDY** FOR THE OPTIMISATION OF YOUR HEATING SYSTEM NOW.

Obsolete technology and non-coordinated plant components often lead to excessive energy consumption. However, many homeowners shy away from renovating their heating systems because they fear high costs.

For this reason, the German Federal Office for Economic Affairs and Export Control (BAFA) has launched a subsidy programme for heating optimisation. The aim of the subsidy programme is to motivate homeowners to renew their heating systems with attractive, non-repayable subsidies. Among other things, this is intended to make an important contribution to the environmentally friendly supply of heat in Germany.

In January 2021, the grant funding for individual measures came into effect as part of the German Federal Subsidy Programme for Efficient Buildings (Bundesförderung für effiziente Gebäude – Einzelmaßnahmen, BEG EM), with which applications for subsidising individual measures can now also be submitted to the BAFA. Central space heaters that distribute heat to different rooms via a liquid medium are not affected by this regulation.



WHAT IS SUBSIDISED? AND DOES THE SUBSIDY ALSO APPLY TO ALRE PRODUCTS?

Within the framework of BAFA subsidies, two measures for heating optimisation are subsidised at 20 per cent by the state:

- 1. Climate-friendly heating using renewable energies**
(for example, heat pumps, pellet heating systems, hybrid heating systems or solar thermal power plants) – 20 to 45 per cent subsidy
- 2. Measures for optimising heating**
(for example, hydraulic balancing including the replacement of heating pumps) – 20 per cent subsidy

For heating optimisation via hydraulic balancing, you can also have our energy-saving alre controllers installed by a specialist technician. The acquisition and installation costs are also subsidised at 20 per cent.

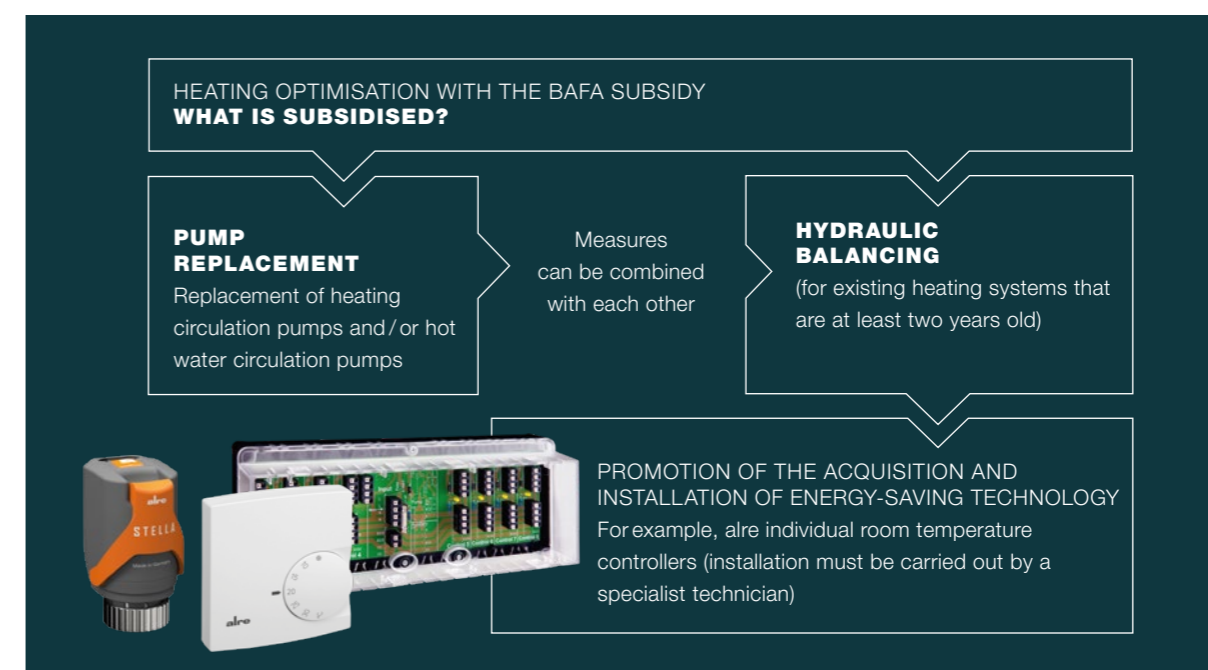

WHO CAN APPLY FOR THE SUBSIDY?

In principle, private individuals, companies, freelancers, municipalities, regional authorities and special-purpose associations as well as other legal entities under private law (in particular associations, foundations, non-profit organisations or cooperatives) are entitled to support. The German Federal Government, German Federal States and their institutions are excluded from funding.

Further information on the contents, procedures and terms and conditions can be found at www.bafa.de

- 1. Step**
Register on the BAFA website
- 2. Step**
Contract a specialist technician and optimise the heating system
- 3. Step**
Submit the subsidy application and invoice copy



SENSOR CHARACTERISTIC CURVES

TABLE OF SENSOR VALUES

TEMPERATURE	PT 100	PT 1000	NI 1000	'SENSOR 0' NTC 2K25	'SENSOR 1' NTC 1KO	'SENSOR 2' NTC 47K	'SENSOR 3' NTC 8K
°C	Ω	Ω	Ω	Ω	Ω	Ω	Ω
-50	80.30	803.00	742.55	151398	32540	3152409	537827
-45	82.30	823.00	766.76	106557	24432	2230085	378534
-40	84.30	843.00	791.31	75923	18515	1595524	269709
-35	86.20	862.00	816.21	54731	14156	1153886	194427
-30	88.20	882.00	841.46	39895	10916	843120	141724
-25	90.20	902.00	867.04	29390	8486	622133	104107
-20	92.20	922.00	892.96	21871	6648	463401	77696
-15	94.10	941.00	919.22	16434	5248	348285	58379
-10	96.10	961.00	945.82	12462	4172	264028	44269
-5	98.00	980.00	972.74	9533	3340	201812	33866
0	100.00	1000.00	1000.00	7355	2691	155480	26126
5	102.00	1020.00	1027.59	5719	2182	120696	20318
10	103.90	1039.00	1055.52	4482	1780	94377	15923
15	105.80	1058.00	1083.77	3539	1460	74314	12570
20	107.80	1078.00	1112.36	2813	1205	58910	9994
25	109.70	1097.00	1141.29	2252	1000	47000	8000
30	111.70	1117.00	1170.56	1814	834	37732	6445
35	113.60	1136.00	1200.16	1471	699	30472	5224
40	115.50	1155.00	1230.11	1199	588	24750	4260
45	117.50	1175.00	1260.41	984	498	20214	3494
50	119.40	1194.00	1291.05	811	423	16597	2882
55	121.30	1213.00	1322.05	673	361	13697	2389
60	123.20	1232.00	1353.40	560	309	11360	1991
65	125.50	1252.00	1385.12	469	266	9466	1667
70	127.10	1271.00	1417.21	395	230	7925	1402
75	129.00	1290.00	1449.67	334	199	6664	1185
80	130.90	1309.00	1482.50	283	173	5627	1006
85	132.80	1328.00	1515.73	241	151	4771	857
90	134.70	1347.00	1549.34	207	133	4062	734
95	136.60	1366.00	1583.36	177	117	3471	631
100	138.50	1385.00	1617.79	153	103	2978	544
105	140.40	1404.00	1652.62	132	91	2563	471
110	142.30	1423.00	1687.89	115	81	2215	409
115	144.20	1442.00	1723.58	100	72	1919	356
120	146.10	1461.00	1759.72	88	64	1669	12
125	148.00	1480.00	1796.30	77	57	1456	273
130	149.80	1498.00	1833.35	68	51	1274	240
140	153.60	1536.00	1908.87	53	41	984	188
150	157.30	1573.00	1986.35	42	34	769	148



SENSOR CHARACTERISTIC CURVES

TABLE OF SENSOR VALUES

TEMPERATURE	'SENSOR 4' NTC 10K	'SENSOR 5' NTC 50K	'SENSOR 6' NTC 100K	'SENSOR 8' NTC 2K	'SENSOR 51' KTY 81-121	'SENSOR 57' KTY 11-7
°C	Ω	Ω	Ω	Ω	Ω	Ω
-50	672283	2820844	8276704	77977	510	1051
-45	473168	2027885	5751387	57655	535	1103
-40	337137	1473182	4044707	43039	562	1156
-35	243033	1080969	2877133	32427	589	1212
-30	177155	800794	2069021	24651	617	1269
-25	130508	598684	1503450	18902	647	1328
-20	97120	451517	1103398	14615	677	1390
-15	72973	343390	817535	11391	708	1453
-10	55337	263262	611269	8947	740	1518
-5	42333	203390	461045	7079	773	1586
0	32658	158300	350656	5642	807	1655
5	25397	124082	268840	4527	842	1726
10	19903	97925	207702	3657	877	1799
15	15713	77789	161654	2973	914	1874
20	12492	62184	126708	2431	951	1951
25	10000	50000	100000	2000	990	2030
30	8056	40455	79428	1654	1029	2111
35	6530	32910	63489	1376	1070	2194
40	5325	26916	51056	1151	1111	2279
45	4368	22129	41297	967	1153	2366
50	3602	18285	33591	816	1196	2456
55	2986	15182	27470	693	1241	2545
60	2488	12664	22582	590	1286	2638
65	2084	10612	18656	505	1331	2733
70	1753	8931	15478	434	1378	2829
75	1481	7547	12917	374	1426	2928
80	1258	6404	10821	324	1475	3029
85	1072	5456	9105	282	1525	3131
90	917	4665	7693	246	1575	3236
95	788	4004	6527	215	1627	3342
100	680	3448	5559	189	1679	3451
105	588	2980	4752	167	1732	3561
110	511	2584	4077	147	1786	3674
115	445	2248	3511	130	1841	3788
120	389	1962	3033	116	1896	3905
125	342	1717	2629	103	1950	4023
130	301	1507	2287	91	2003	4143
140	235	1171	1745	73	2103	4390
150	185	920	1348	60	2189	4644



TECHNICAL TERMS

TECHNICAL TERMS	DEFINITION/EXPLANATION
Range limitation (mechanical):	Below the adjusting knob, there are 'setting flags' (red/blue) for mechanically delimiting the min./max. temperature range. In this manner, an undesired mis-setting of the setpoint can be prevented, for example, in children's rooms or public buildings.
Bimetal:	Thermo-bimetal is generally constructed of layers of metal or alloys of more or less the same thickness, which are firmly joined to one another and have different coefficients of thermal elongation. As a result, they bend under temperature changes, so that upon heating, the side with the component that has a lower heat elongation becomes hollow. The heat is transferred by conduction, radiation or convection from the surroundings (indirect heating).
Defrosting:	Defrosting is the regular de-icing or heating up of the heat exchanger or cooling unit to maintain efficient operation of the system.
Intrinsic safety (JTU, JTL)	Intrinsic safety / protection against cold: The devices are intrinsically safe, i.e., upon loss of the sensor medium owing to sensor rupture, for example, the burner is switched off. Since minus temperatures generate the same effect through volume reduction of the sensor medium, the devices are adjusted by means of the 'cold screw' such that they switch off the burner only at temperatures below $-15\text{ }^{\circ}\text{C}$. They can only be switched on again manually at temperatures above approx. $-5\text{ }^{\circ}\text{C}$ by means of the manual reset button.
Air conditioner, 2-pipe fan convector (fan coil):	The 2-pipe air conditioners are supplied with heating or cooling water for heat exchange, depending on the requirement, through the same pipe system via 2 pipes (inflow and outflow).
Air conditioner, 4-pipe fan convector (fan coil):	The 4-pipe air conditioners are supplied with heating or cooling water for heat exchange, depending on the requirement, through a heating circuit and a cooling circuit (4 pipes).
Cooling ceiling:	The cooling ceiling belongs to the group of panel heaters. Cooling ceilings are used often in office spaces for passive cooling. In such systems, cold water (usually at $16\text{ }^{\circ}\text{C}$) flows through a network of pipes and cools the room air. Lower inflow temperatures are not possible because of condensation water formation.
Neutral zone:	The control range in which neither heating nor cooling takes place is called the neutral zone.
NC contact (bimetal):	The control contact opens with increasing temperature and closes at dropping temperature (for 'heating').
Proportional band (p-band):	The proportional band is the range around the target temperature within which the controller delivers a steady output signal. This means that the room temperature is kept more or less constant within the proportional band by the controller (if the heating capacity is sufficient).
2-point control (ON/OFF control):	Control algorithm which, for example, switches off the output when the set temperature is exceeded and switches it on again when the current temperature falls short of the setpoint value. The temperature in the room is always subject to certain variations (control deviations). This deviation results from the switching temperature difference of the controller and the properties of the room, such as heating speed, heat loss etc.
3-point control:	In a 3-point control system, the controller can change between the operating modes heating, neutral zone and cooling.
PWM (pulse width modulation):	Process for generating a continuous-like transmission behaviour in a control path. By varying the power-on time at the input, owing to the time constant of the transmission path, a continuous-like (smooth) signal waveform is generated at its output.
Switching difference (hysteresis):	Difference between the switching on and switching off of the heater or the controller. a) There is the switching temperature difference of the controller, which depends on the construction of the device. b) There is the switching temperature difference of the room, which is dependent on the behaviour of the entire control path, i.e. on the floor design, the action of external heat sources, the installation location of the controller and the controller itself. The switching temperature difference always refers to the controller. It does not express the actual switching temperature difference of the control path. The latter changes according to the deployment location and conditions. Any indoor temperature is constantly subject to variations. This deviation results from the switching temperature difference of the controller and the properties of the room, such as heating speed, heat loss etc.
NO contact (bimetal):	NO contact (bimetal): The control contact closes with increasing temperature and opens at dropping temperature (for 'cooling').
Toggler (bimetal):	This is a toggler with an NC contact and an NO contact. It operates as described for NC and NO contacts.
Split unit/ multi-split unit:	Split AC units consist of at least two heat exchangers in which one is installed as a vaporiser in the rooms to be cooled and the other serves as a condenser for heat dissipation. Most split units allow reverse operation for heating the rooms if this is required. Multi-split units consist of several vaporisers connected to a condenser (liquefier).
Valve actuator:	Electrical controllable valve for regulating, for example, the hot water flow in heating systems. A distinction is made here between ON/OFF valve actuators and proportional valve actuators. Proportional valves are designed for connecting controllers with a continuous control mode.



TECHNICAL TERMS

TECHNICAL TERMS	DEFINITION/EXPLANATION
Continuous control:	The controller provides an analogue output signal. The value of the output signal changes continuously, i.e., without any steps or jumps, in response to the output signal.
Temperature reduction (TR):	The TR is also implemented via a resistor, as is the case with thermal recirculation. This resistor is activated manually or by a timer. As a result, the bimetal is made to feel a simulated temperature that is about 4 K higher than the actual temperature in the room. Consequently, in a room with a controller setting of, for example, $20\text{ }^{\circ}\text{C}$, the temperature in the room can drop to a value 4 K lower, to max. $16\text{ }^{\circ}\text{C}$. If the temperature drops further, the heating system switches on again, and at $> 16\text{ }^{\circ}\text{C}$, it gets switched off. The magnitude of the temperature reduction to be actually achieved depends on the insulation of the building and the reduction period (one night, weekend, holiday).
Thermal recirculation (RF):	By means of an additional integrated heating resistor, the controller is made to switch off at the right time during the heating process. As a result, exceeding the desired room temperature is minimised, and there is a smaller switching difference.
Heat pump:	Rooms can be cooled or heated with heat pumps. Modern systems allow efficient heating and cooling operation since they allow reversible process reversing.
Reversing valve:	A reversing valve (4-way control valve) facilitates a reversing cycle by turning the condenser (liquefier) into an evaporator which causes the cooling unit to heat up or defrost.
Valve protection function	Valve and pump protection serves to prevent the valve seat and / or pumps from corroding during long downtimes. It is recommended to activate valve protection for hot water heating systems. If valve and pump protection is activated, the valve or a heating pump is operated once on Mondays between 1100hrs and 1200hrs for 5 minutes. Valve and pump protection only becomes active if no heating has taken place within the last week. This avoids unnecessary additional heating at times of year when heating is in use and does not affect the control system.
Evaporator / liquefier:	A liquefier or condenser is a heat exchanger in a cooling unit that liquefies a gaseous medium through the dissipation of heat. Usually, further cooling of the cooling agent takes place in the liquefier. According to the definition of terms in the European Standard EN 378 Part 1, the condenser in cooling units is called the liquefier in order to easily distinguish it from an electrical condenser. The vaporiser implements the opposite process, evaporating the liquid medium by heating it up.

INDEX BY PRODUCT DESIGNATIONS

PRODUCT	TYPE	PG	PAGE
Cover sets for flush-mounted controllers (heating technology)	JZ-0 ...	I	79, 81
Cover sets for flush-mounted controllers (air-conditioning technology)	JZ-0 ...	I	129
Adaptation list for flush-mounted controllers (HTRRUu)	Adaptation list, flush-mounted		95
Adaptation list for flush-mounted controllers (KTRRUu)	Adaptation list, flush-mounted		136
Adaptation list for flush-mounted controllers (RTBSU)	Adaptation list, flush-mounted		82
Contact temperature sensor with passive output	ALF	III	217
Contact thermostats, capillary system	ATR 83	II	177
Outdoor temperature sensor with passive output, sensor sleeve lead-out	AFH	III	214
Outdoor temperature sensor with passive output, internal sensor	AF	III	213
BACnet individual room controller	KTRBUu...	IV	45
Ball impact / sunlight / rain protection	S protection 01	III	213
Cover sets for RTBSU in 50 x 50 mm, 55 x 55 mm and 70 x 70 mm	Cover sets for RTBSU	I	79
Differential pressure switch, adjustable	JDL-111 ...-117	III	198
Differential pressure switch, adjustable	JDW-3/ -5/ -10	II	198
Integrated duct temperature sensor with passive output	EKF	III	220
Single-stage industrial thermostats, capillary system, external sensor	JET-1... R	II	173
Single-stage plant room thermostats, capillary system, external sensor	RTKSA	II	162
Single-stage industrial thermostats, capillary system, 2 separate setting ranges, external sensor	JET-30/ -31	II	164
Single-stage capillary thermostats	JET-1...	II	174
Electrothermal valve actuators	ZBOOA ...	I	109, 149
Wet room controller / double thermostat, bimetal	PTR 40	II	165
Frost protection thermostats, capillary system, switching	RTKSA/JTF-1 to - 25	II	179
Wireless actuators heating /cooling (4/8-channel)	KTFRL...	I	28
Wireless temperature sensors without clock / with clock	FTRFB .../FTRFBu .../FTRFud ...	I	16
Wireless actuators heating (1 / 4/ 8-channel)	HTFR .../HTFMA...	I	22
Wireless actuator (cooling)	CTFRB	I	26
Floor temperature controllers, electronic (surface-mounted)	HTRRB ...	I	96
Floor temperature controllers, electronic (flush-mounted)	RTERU/FETR	I	100
Hygrostat (flush-mounted)	FHY 101.060	I	142
Hygrostats (surface-mounted)	RFHSB	I	143
Hygro-thermostat (surface-mounted)	RKDSB	I	143
Hygrostat, duct assembly, 1-stage and 2-stage	HI	II	195
Cable temperature sensor	KF	III	216
Duct thermostat, capillary system	JTU-1 ... -50	II	186
Terminal strip for heating manifold	VOOPL	I	110
Terminal strip for heating manifold with heating /cooling toggling	VOORL	I	145
Climate controllers, electronic (flush-mounted) with clock	KTRRUu	I	131
Climate controllers, electronic with triac output	KTRTB	I	119
Climate controllers for cooling ceilings, electronic	KTRRU ...	I	127
Climate controllers, mechanical (surface-mounted)	KTBSB	I	120
Cooling ceiling controllers, electronic (surface-mounted)	KTRRB-05 ...	I	124
Air heater thermostat, capillary system, 2 functions	JTL-2 ... -11	II	184
Air heater thermostat, capillary system, 3 functions	JTL-8 NR ... -17 NR	II	184
Airflow monitors	WSERD	III	200
Cable temperature sensor	KF	III	216
Transducer 'differential pressure – air'	MDEKD ...	III	222

INDEX BY PRODUCT DESIGNATIONS

PRODUCT	TYPE	PG	PAGE
Mounting flange for EKF, IKF	MF	III	231
Pendulum temperature sensors	PF	III	218
Frames for mounting all 50 x 50 flush-mounted units	Frame	I	79, 81
Room temperature / climate controllers, electronic (surface-mounted)	KTRRB-117 ...	I	122
Room temperature controller, electronic (flush-mounted)	HTRRUt	I	90
Room temperature controller, electronic (surface-mounted), design 'Berlin 1000'	HTRRBd	I	72
Room temperature sensor, surface-mounted	BTF2	III	210
Room temperature controller, flush-mounted	FUF	III	211
Room temperature controllers, mechanical (surface-mounted), design 'Berlin 1000'	RTBSB-201 ...	I	65
Room temperature controllers, mechanical (surface-mounted), design 'Berlin 2000'	RTBSB-001 ...	I	59
Room temperature controllers, mechanical (surface-mounted plug) for mobile heaters	RTBSB-001.4 ...	I	68
Controllers for distributor assembly (hat rail), electronic	ITR 79	II	192
Sauna controllers	SAUNATHERM VU / HYGROTHERM VU	III	226
Control cabinet hygrostat	RFHSS	II	191
Control cabinet thermostats	RTBSS	II	190
Control cabinet thermostat, electronic	CTRRS / KTRRN		188
Protective sleeve for screed mounting of sleeve sensor HF / cable sensor KF (Ø 7.7 mm)	THF	II	230
Protection coil for sleeve and cable sensors	SW-200 / SW-200-12	II	229
Protection coil for RTKSA	SWK	II	228
Plug-in socket	JZ-19	I	68
Continuous room temperature controller, electronic, internal or external sensor	KTRVB ...	I	137
Radiation temperature sensor	STF	III	219
Flow monitors, mechanical	JSF-1E ... 4E / ... RE	II	201
Flow monitors, mechanical	JSW	III	204
Immersion sleeves for HF, EKF, IKF (Ø 6 mm)	THMs / THV	II	231
Immersion sleeves for capillary / frost protection thermostats and sleeve sensors (Ø 7 mm)	NTH / TH	II	230
Immersion sleeves for RTKSA	NTHK / THK	II	228
Dew point sensor	TPS	I	140
Dew point monitors, electronic	WFRRN	I	139
Technical terms	Technical terms		244
Tips for heating installers and electricians	Tips		237
Clock thermostats, electronic (surface-mounted) for room temperature control	HTRRBu ...	I	70
Clock thermostats, electronic (surface-mounted) for floor heating systems	HTRRBu ...	I	98
Universal pressure switch	JPS	II	206
Universal capillary thermostats as boiler, ventilation or contact controller (TR / TW / TB / STB / STW)	RTKSA	II	166
Universal capillary double thermostats as boiler, ventilation or contact controller (TR / TW / TB / STB)	RTKSA	II	162
Universal controllers, electronic, remote sensor, single-stage	ETR 77	II	194
Flush-mounted thermostats, electronic, with clock, room or floor	HTRRUu ...	I	92
Flush-mounted thermostats, mechanical	RTBSU	I	73
Heat conduction paste	WP-01	II	24
Wind indicator relays, mechanical for air duct	JSL-1E	II	197
Accessories	Accessories		230
Two-stage capillary thermostat	JMT-206 x	II	176

INDEX BY TYPE DESIGNATIONS

TYPE	PG	PRODUCT	PAGE
Adaptation list, flush-mounted		Adaptation list for flush-mounted controllers (HTRRUu)	95
Adaptation list, flush-mounted		Adaptation list for flush-mounted controllers (KTRRUu)	136
Adaptation list, flush-mounted		Adaptation list for flush-mounted controllers (RTBSU)	82
AF	III	Outdoor temperature sensor with passive output, internal sensor	213
AFH	III	Outdoor temperature sensor with passive output, sensor sleeve lead-out	214
ALF	III	Contact temperature sensor with passive output	217
ATR 83	II	Contact thermostats, capillary system	177
BTF2	III	Room temperature sensor, surface-mounted	210
CTFRB	II	Wireless cooling actuator, surface-mounted	26
CTRRS	II	Control cabinet thermostat, electronic	188
Cover sets for RTBSU	I	Cover sets for RTBSU in 50 x 50 mm, 55 x 55 mm and 70 x 70 mm	79
EKF	III	Integrated duct temperature sensor with passive output	220
ETR 77	II	Universal controllers, electronic, remote sensor, single-stage	194
FETR	I	Floor temperature controllers, electronic (flush-mounted)	101
FHY 101.060	I	Hygrostat (flush-mounted)	142
FTRFB ... / FTRFBu ... / FTRFUd ...	I	Wireless sensors without clock / with clock	16
FUF	III	Room temperature sensor (flush-mounted)	211
HI	II	Duct hygrostat, 1-stage and 2-stage	195
HTFR ...	I	Wireless actuators heating (1 / 4 / 8-channel)	22
HTRRB ...	I	Floor temperature controllers, electronic (surface-mounted)	96
HTFMA	I	Wireless heating control, motorised actuator	22
HTRRBd	I	Electronic surface-mounted room temperature controller	72
HTRRBu ...	I	Clock thermostats, electronic (surface-mounted) for room temperature control	70
HTRRBu ...	I	Clock thermostats, electronic (surface-mounted) for floor heating systems	98
HTRRUu ...	I	Flush-mounted thermostats, electronic, with clock, room or floor	92
HTRRUt	I	Electronic surface-mounted room temperature controller	90
IKF1	III	Industrial integrated duct sensor with passive output	221
ITR 79	II	Controllers for distributor assembly (hat rail), electronic	192
JDL-111 to -116	II	Differential pressure switch, adjustable	198
JDW-3 / -5 / -10	II	Differential pressure switch, adjustable	198
JET-1... R	II	Single-stage industrial thermostats, capillary system, external sensor	173
JET-1...	II	Single-stage capillary thermostats	174
JMT-206 x	II	Two-stage capillary thermostats	176
JPS	II	Universal pressure switch	206
JSF-1E ... 4E / ... RE	II	Flow monitors, mechanical	201
JSL-1E	II	Wind indicator relays, mechanical for air duct	197
JSW	III	Flow monitors, mechanical	204
JTF-1 to -25	II	Frost protection thermostats, capillary system, switching	181
JTL-2 ... -11	II	Air heater thermostat, capillary system, 2 functions	184
JTL-8 NR ... -17 NR	II	Air heater thermostat, capillary system, 3 functions	184
JTU-1 ... -50	II	Duct thermostat, capillary system	186
JZ		Accessories	232
JZ-0 ...	I	Cover sets for flush-mounted controllers (heating technology)	79, 81
JZ-0 ...	I	Cover sets for flush-mounted controllers (air-conditioning technology)	129
JZ-19	I	Plug-in socket	68
JZ-33	II	RTKSA seal set	230
KF	III	Cable temperature sensor	216
KTBSB	I	Climate controllers, mechanical (surface-mounted)	120
KTFRL...	I	Wireless actuators heating / cooling (4 / 8-channel)	28

INDEX BY TYPE DESIGNATIONS

TYPE	PG	PRODUCT	PAGE
KTRBUu	IV	BACnet individual room controller	45
KTRRB-05 ...	I	Cooling ceiling controllers, electronic (surface-mounted)	124
KTRRB-117 ...	I	Room temperature / climate controllers, electronic (surface-mounted)	122
KTRRN	II	Control cabinet thermostat, electronic	189
KTRRU ...	I	Climate controllers for cooling ceilings, electronic	127
KTRRUu	I	Climate controllers, electronic (flush-mounted) with clock	131
KTRTB	I	Climate controllers, electronic with triac output	119
KTRVB ...	I	Continuous room temperature controller, electronic, internal or external sensor	137
MDEKD ...	III	Transducer 'differential pressure – air'	222
MF	III	Mounting flange for EKF, IKF	231
NTH / TH	II	Immersion sleeves for capillary / frost protection thermostats and sleeve sensors (Ø 7 mm)	230
NTHK / THK	II	Immersion sleeves for RTKSA	228
PF	III	Pendulum temperature sensors	218
PTR 40	II	Wet room controller, bimetal	165
Frame	I	Frames for mounting all 50 x 50 and 55 x 55 flush-mounted units	103
RFHSB	I	Hygrostats (surface-mounted)	143
RFHSS	II	Control cabinet hygrostat	191
RKDSB	I	Hygro-thermostat (surface-mounted)	143
RTBSB-001.4 ...	I	Room temperature controllers, mechanical (surface-mounted plug) for mobile heaters	69
RTBSB-001 ...	I	Room temperature controllers, mechanical (surface-mounted), design 'Berlin 2000'	59
RTBSB-201 ...	I	Room temperature controllers, mechanical (surface-mounted), design 'Berlin 1000'	65
RTBSS	II	Control cabinet thermostats	190
RTBSU	I	Flush-mounted thermostats, mechanical	73
RTERU	I	Floor temperature controllers, electronic (flush-mounted)	100
RTKSA-00x.xxx	II	Universal capillary thermostat	166
RTKSA-01x.xxx	II	Universal capillary double thermostat	170
RTKSA-10x.xxx	II	Plant room thermostat	170
RTKSA-114.xxx	II	Plant room double thermostat	164
RTKSA-20x.xxx	II	Frost protection thermostat	179
SAUNATHERM VU / HYGROTHERM VU	III	Sauna controllers	226
S protection 01	III	Ball impact / sunlight / rain protection	213
STF	III	Radiation temperature sensor	219
SW-200 / SW-200-12	II	Protecting coil for capillary thermostats, sleeve sensors and air sensors	229
SWK	II	Protection coil for RTKSA	229
Technical terms		Technical terms	244
TH / NTH	II	Immersion sleeves for capillary / frost protection thermostats and sleeve sensors (Ø 7 mm)	230
THF	II	Protective sleeve for screed mounting of sleeve sensor HF / cable sensor KF (Ø 7.7 mm)	230
THK / NTHK	II	Immersion sleeves for RTKSA	228
THMs / THV	II	Immersion sleeves for HF, EKF, IKF, KF (Ø 6 mm)	231
Tips		Tips for heating installers and electricians	237
TPS	I	Dew point sensor	125
Type comparison		Old / new capillary thermostats from the plant engineering field	162
VOOPL	I	Terminal strip for heating manifold	110
VOORL	I	Terminal strip for heating manifold with heating / cooling toggling	145
WFRRN	I	Dew point monitors, electronic	139
WP-01	II	Heat conduction paste	24
WSERD	III	Airflow monitors	200
ZB00A ...	I	Electrothermal valve actuators	109, 149
Accessories		Accessories	232

TERMS AND CONDITIONS OF SALE AND SUPPLY

THE ALRE-IT

1. GENERAL

In addition to the General Terms and Conditions of Delivery for Products and Services of the Electrical Industry and the Green Terms and Conditions of Delivery as of January 2022 (hereinafter referred to as 'GL'), the following provisions shall apply to all business relations with our customers who are contractors, legal entities under public law or special funds under public law (hereinafter referred to as 'Customer'). These can be viewed and downloaded on our website at www.alre.de. We are the 'Supplier' as defined by the GL.

2. QUOTATIONS

- 2.1. Our offers are subject to change and without obligation, unless we have expressly designated them as binding.
- 2.2. Declarations of acceptance and purchase orders need our confirmation (in written and/or electronic form) for them to become legally valid; the same applies to supplements, changes and subsidiary agreements. Drawings, illustrations, dimensions and other performance data are only binding if such terms are expressly agreed upon.

3. PRICES AND PRICE ADJUSTMENT

- 3.1. In addition to the regulations in Art. II (1) of the GL, freight, insurance and customs costs are not included in the prices.
- 3.2. Price changes caused by changes to the contract product or by changes to the requirements of the contract product are negotiated and determined on the basis of a joint cost analysis.

4. DEADLINES FOR DELIVERY/DELAY

In addition to the provisions in Art. IV (2) of GL, we will inform the Customer immediately if the service is not available within the extended delivery periods. In this case, we shall be entitled to withdraw from the contract in whole or in part. Any consideration already rendered by the Customer shall be reimbursed by us without delay. The case of

non-availability of the service in this sense shall include in particular the failure of our suppliers to deliver to us on time if we have concluded a congruent hedging transaction or if neither we nor our suppliers are at fault.

5. LIABILITY

- 5.1. In principle, our liability is based on GL, in particular Art. XII.
- 5.2. In addition to Art. IV (4), Art. VIII (12) and Art. XI (1) of GL, we, our legal representatives, executive employees or agents shall be liable under this contract for minor negligence in the event of a breach of an 'essential' obligation under this contract. 'Essential' obligations are those obligations which are necessary for the performance of the contract and the breach of which would jeopardise the achievement of the purpose of the contract and on the observance of which the Customer may therefore regularly rely. In these cases, liability is limited to typical and foreseeable damages.

6. PACKAGING

The packaging will not be taken back, unless this is required by law.

7. TERMS OF PAYMENT

- In addition to Article II of GL, the following provisions shall apply:
- 7.1. Our invoices are payable within 30 days from the date of invoice.
- 7.2. The Customer shall be in default upon expiry of the aforementioned payment period. The amount to be paid shall bear interest during the period of default at the applicable statutory default interest rate. We reserve the right to assert further claims for damages caused by default.
- 7.3. Once an agreement is made, we are entitled to make a delivery in whole or in part only against advance payment or cash on delivery.
- 7.4. If it becomes apparent after conclusion of the contract that our claim to payment is at risk due to the purchaser's inability to

pay, we shall be entitled – if applicable, after setting a deadline (Section 321 of the German Civil Code (BGB)) – to withdraw from the contract in accordance with the statutory provisions on refusal of performance.

7.5. The Customer shall only be entitled to retention rights to the extent that his claim has been legally established or is undisputed. In the event of defects in the delivery, the Customer's counter rights, in particular the rights under Art. VIII (6) of the GL shall remain unaffected.

8. MATERIAL DEFECTS

- 8.1. In deviation from Art. VIII (1)(1) of the GL, exclusively Section 434 is valid.
- 8.2. Supplementary to item. VIII of GL, the purchaser's claims for defects presuppose that it has complied with its statutory obligations to inspect and give notice of defects (Sections 377, 381 of the German Commercial Code – HGB). The Customer must inspect the goods immediately after delivery. Obvious defects must be reported in writing by the Customer immediately, on the seventh day at latest. If a hidden defect only becomes apparent at a later date, the Customer must nevertheless notify us of this in writing immediately after becoming aware of it.
- 8.3. Supplementary to item. VIII of GL, there shall be no warranty claims if our operating or assembly instructions are not followed, changes or repair work are carried out on our products or parts are replaced or our products are used contrary to the contractually stipulated suitability. The same applies if the purchaser, in a manner that is not transparent to us, joins, mixes or processes our products, contrary to their normal and/or usual suitability, with his products or products of third parties, or uses our products contrary to the state of science and technology, or in any other manner contrary to their normal and/or usual suitability.
- 8.4. Technical data on our products in offers, catalogues and other product descriptions has been determined by us in a suitable test environment (we will be happy to provide information on request)

and represents the sole basis for agreed quality. Testing for suitability for the purpose intended by the Customer or for the use of the part under specific usage conditions is the responsibility of the Customer; we do not provide any kind of guarantee.

8.5. Subsequent performance does not include the removal of the defective item or its re-installation if we were not originally obliged to install it.

8.6. In addition to Art. VIII (10 and 11) of the GL, Section 439 BGB remains unaffected. Section 8.2 remains unaffected.

9. USE OF THE B@HOME SYSTEM

The Terms of Use available on our website at www.alre.de apply for the use of the b@home portal and the b@home app including the updates ('b@home system'), which are made available to the Customer by us. Should the Customer use the b@home system for a company, he accepts the validity of these terms of use in a legally binding manner for this company.

Last updated: December 2022

GENERAL NOTES

THE ALRE-IT

SAFETY REGULATIONS

When handling products, the applicable EU Directives and the assembly and installation instructions in the operating manuals must be followed without fail.

NOTES ON TECHNICAL DATA

Technical data has been determined by us in a suitable test environment (we will be happy to provide information on request) and represents the sole basis for agreed quality. All the equipment and components shown in this catalogue may only be used in keeping with their intended purpose. Testing for suitability for the purpose intended by the Customer/client or for the use of the part under specific usage conditions is the responsibility of the Customer/client; we do not provide any kind of guarantee.

We reserve the right to make changes to products and documentation as may be required for technical progress and continuous improvement and therefore, there may be deviations from the information in the catalogue. Printing errors excepted.

Any reproduction of this documentation, even in extract form, is not permitted without the consent of ALRE-IT Regeltechnik GmbH, Berlin. The place of jurisdiction is Berlin.

This price list is valid as of **01.01.2025**. This price list supersedes all previous price lists and renders them invalid. A significant increase in the market price of raw materials and electronic components has led to us also having adjusted our prices.

We reserve the right to make changes.

REACH, ROHS, WEEE

REACH: The company ALRE-IT Regeltechnik exclusively sells non-chemical products (articles) from which no substance is released under normal and reasonably foreseeable conditions of use. The products of ALRE-IT Regeltechnik GmbH and their packaging comply with the permissible threshold values for substances on the candidate list according to REACH Regulation 1907/2006 and all the published amendments (provisions) pertaining to it.

RoHS: As of 01/07/2013 the CE marking confirms that the respective products comply with the requirements of the RoHS 2011/65/EU and (EU) 2015/863 Directives.

WEEE: The company ALRE-IT Regeltechnik is registered as a manufacturer according to Section 3 (9) of the ElektroG (German Electricals Act) and under the registration number DE 58457361 at the EAR. All products manufactured by ALRE-IT Regeltechnik that fall within the scope of the ElektroG meet the legal requirements and thus ensure the proper collection, storage, recycling and environmentally friendly disposal of old equipment.

PRODUCT TESTING

For information on our declarations of conformity and various product tests, please visit our website at **www.alre.de**.

CONTACT INFORMATION AND CONTACT PERSONS

COMPANY HEADQUARTERS

ALRE-IT Regeltechnik GmbH
Richard-Tauber-Damm 10
12277 Berlin, Germany
Phone: (+49) 3039 9840
Fax: (+49-30) 3917 005
E-Mail: www.alre.de
Internet: www.alre.de

SALES MANAGEMENT

Friedrich von der Lüche
Office
Phone: (+49-30) 3998 4160
Fax: (+49-30) 3998 4129
E-Mail: vertrieb@alre.de

Northern region

German postal code zones
02, 03, 1, 2, 30, 31, 38 and 39
Internal contact
Phone: (+49-30) 3998 4123
Fax: (+49-30) 3917 005
E-Mail: vertrieb@alre.de

Western region

German postal code zones
32-35, 360-363, 365-37, 4,
50-53, 57-61 and 657-659
Internal contact
Phone: (+49-30) 3998 4127
Fax: (+49-30) 3917 005
E-Mail: vertrieb@alre.de

South-western region

German postal code zones
54-56, 63, 64, 650-656, 66-69 and 7
Internal contact
Phone: (+49-30) 3998 4121
Fax: (+49-30) 3917 005
E-Mail: vertrieb@alre.de

Southern region

German postal code zone
8
Internal contact
Phone: (+49-30) 3998 4121
Fax: (+49-30) 3917 005
E-Mail: vertrieb@alre.de

South-eastern region

German postal code zones
01, 04-09, 364 and 9
Internal contact
Phone: (+49-30) 3998 4123
Fax: (+49-30) 3917 005
E-Mail: vertrieb@alre.de

EXPORT

Internal contact
Phone: (+49-30) 3998 4213
Fax: (+49-30) 3917 005
E-Mail: vertrieb@alre.de

SALES PARTNERS ESTONIA, LATVIA, LITHUANIA



OLIL SIA
Kr.Valdemāra iela 157
birojs 118
1013 Riga
Phone: +371 672 70580
Email: olil@olil.lv
Internet: www.olil.lv

SALES PARTNERS POLAND, ROMANIA, UKRAINE, BELARUS



DACPOL Sp. z o.o.
ul. Pulawska 34
05-500 Piaseczno, Poland
Phone: (+48-2) 2703 5100
E-Mail: dacpol@dacpol.eu
Internet: www.dacpol.eu

SALES PARTNERS NETHERLANDS



Betec Controls BV
Sleutelbloemstraat 40
7322 AK Apeldoorn
Phone: +31 (0) 578 57 71 79
Email: info@beteccontrols.nl
Internet: www.beteccontrols.nl

SALES PARTNERS FRANCE



DISIMPEX SA
14, rue Joseph Graff
67810 Holtzheim
Phone: (+33-3) 9020 7420
Fax: (+33-3) 8876 9083
E-Mail: info@disimpex.fr
Internet: www.disimpex.com

SALES PARTNERS AUSTRIA

eh-technik

Sonepar Österreich GmbH
Niederlassung eh-technik
Gniglerstraße 54
5020 Salzburg, Austria
Phone: +43 (0)5 1706 16401
E-Mail: eh.technik@sonepar.at
Internet: www.sonepar.at

SALES PARTNERS SWEDEN



BONAB AB
Aröds Industriväg 76
41705 Göteborg, Sweden
Phone: (+46-3) 1724 2424
E-Mail: alre@bonab.se
Internet: www.bonab.se

SALES PARTNERS SWITZERLAND



sensortec AG
Länggasse 13
3280 Murten
Phone: +41 (0) 32 312 70 00
Email: info@sensortec.ch
Internet: www.sensortec.ch

SALES PARTNERS ICELAND



Loft og Raftæki ehf.
Hjallabrekka 1
200 Kópavogur
Iceland
Phone: (+354) 564-3000
E-Mail: loft@loft.is
Internet: www.loft.is

SALES PARTNERS CHINA



Hefei Heating-Cooling
Equipment Control Technology Ltd
Level-7, Block-D, Building-3#,
Hefei Xinglu industrial park
Luyang District
230001 Hefei, China
Phone: (+86-55) 1656 33190
E-Mail: 443231605@qq.com
Contact person: Panpan Li



DBK-Technology Ltd.
Room 10, 3/F, Po Hong Centre
2 Wang Tung Street
Kowloon Bay
Hong Kong
Phone: (+852) 2401 1011
E-Mail: info@dbk-tech.com
Internet: www.dbk-group.com
Internet: www.dbk-cn.com

DBK Industrial Equipment
(Chongqing) Co. Ltd.
Room 5-4, Unit 1, Block 16
No. 18 Qixia Road
Northern New District
Chongqing
P.R.China 401122
Phone: (+86-23) 6342 2511
E-Mail: info-cn@dbk-group.com
Internet: www.dbk-cn.com

SALES PARTNERS LITHUANIA



AUREGIS UAB
Savanoriu pr. 271
50131 Kaunas,
Lithuania
Phone: (+370) 3731 3426
Internet: www.auregis.lt





**alre –
simply
control.**

alre

ALRE-IT
REGELTECHNIK GMBH

Richard-Tauber-Damm 10
12277 Berlin, Germany

Phone: (+49-30) 399 840
Fax: (+49-30) 3917 005
E-mail: mail@alre.de

www.alre.de